

# SPLIT TYPE AIR CONDITIONER (50Hz)

## DUCT type

# SERVICE MANUAL



Indoor unit	Outdoor unit
ART30LUAK	AOT30LMBDL
ART36LUAK	AOT36LMADL
ARTC36LATU	AOT36LMADL

## CONTENTS

SPECIFICATIONS	1
OUTLINE AND DIMENSIONS	2
REFRIGERANT SYSTEM DIAGRAM	3
CIRCUIT DIAGRAM	4
INDOOR PCB CIRCUIT DIAGRAM	5
OUTDOOR PCB CIRCUIT DIAGRAM	6
DIP SWITCH SETTING	10
ERROR CONTENTS	11
PARTS (indoor unit)	12
PARTS (outdoor unit)	14
STANDARD ACCESSORIES	17

# SPECIFICATIONS

## ELECTRICAL DATA

Models	Indoor Unit	ART30LUAK	ART36LUAK ARTC36LATU
	Outdoor Unit	AOT30LMBDL	AOT36LMADL
Power source		240 V 50 Hz	240 V 50 Hz
Cooling Capacity (Max)		8.8 kW (9.8 kW) 30,000 BTU/h (33,500 BTU/h)	10.0 kW (10.5 kW) 34,100 BTU/h (36,000 BTU/h)
Heating Capacity (Max)		9.2 kW (11.2 kW) 31,400 BTU/h (38,200 BTU/h)	10.0 kW (12.5 kW) 34,100 BTU/h (42,700 BTU/h)
Current (Max)	Cooling	13.8 A (15.5 A)	16.7 A (17.6 A)
	Heating	10.7 A (15.9A)	11.7 A (17.6 A)
Input (Max)	Cooling	3.30 kW (3.70 kW)	4.00 kW (4.20 kW)
	Heating	2.55 kW (3.80 kW)	2.80 kW (4.20 kW)
Starting Current		10 A	10 A
E.E.R	Cooling	2.67 kW/kW	2.50 kW/kW
	Heating	3.61 kW/kW	3.57 kW/kW
Moisture Removal		3.0 L/h	3.0 L/h
Maximum current		15.5 A	17.6 A

## FAN

Air Flow	Indoor Unit High (100Pa)		2,500 m3/h 700 L/s
	Outdoor Unit		3,200 m3/h 890 L/s
Operation Sound (Sound Pressure Level)	Indoor Unit	High	45 dB(A)
		Med	38 dB(A)
		Low	32 dB(A)
	Outdoor Unit	Cooling	53 dB(A)
		Heating	54 dB(A)

## MEASUREMENT

Dimensions H×W×D	Indoor	400 × 1,050 × 500 mm
	Outdoor	900 × 900 × 350 mm
Weight Net / Gross	Indoor	45 kg / 50 kg
	Outdoor	70 kg / 78 kg

## COMPRESSOR AND REFRIGERANT

Compressor type	DC Twin Rotary Type	
Discrimination	TNB220FPBMT	
Weight (with oil)	14.3 kg	
Precharge amount	2,800 g	
Refrigerant Type	R410A	
Full charge	10m	2,800 g
	20m	3,300 g
	30m	3,800 g
Additional charge	50 g/m	
Maximum Piping Height	20 m	

# OUTLINE AND DIMENSIONS

(Unit : mm)

## INDOOR UNIT

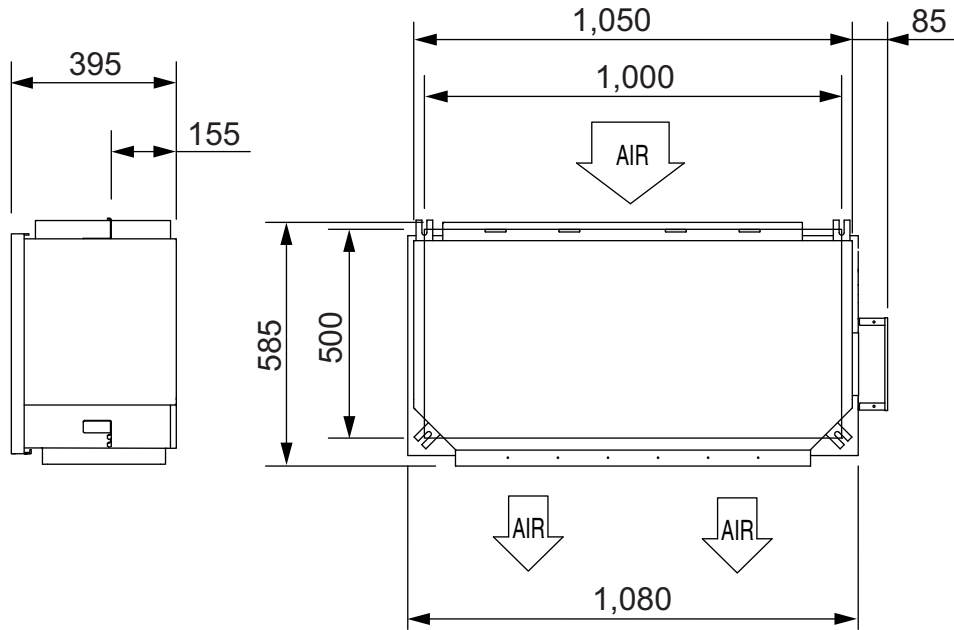

## OUTDOOR UNIT

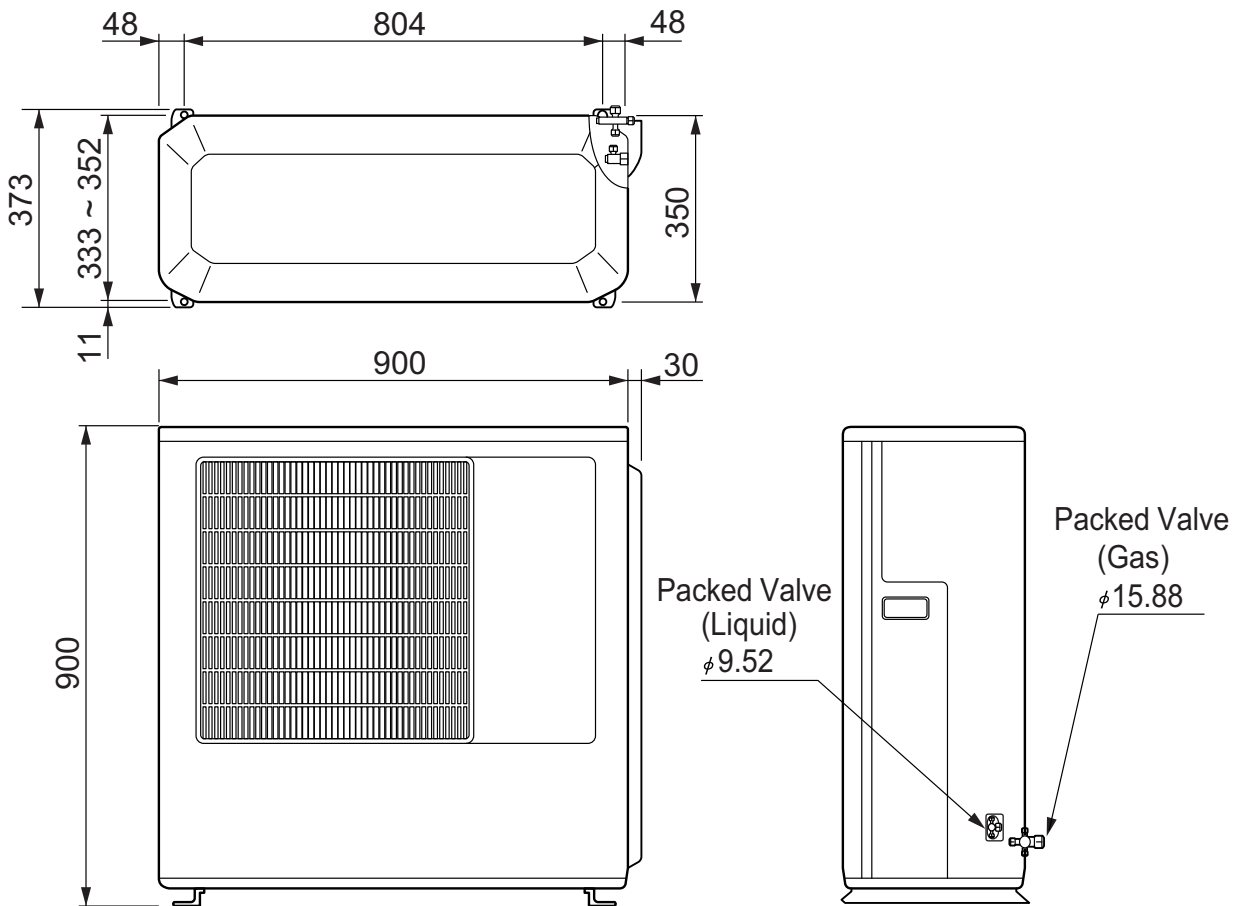

# REFRIGERANT SYSTEM DIAGRAM

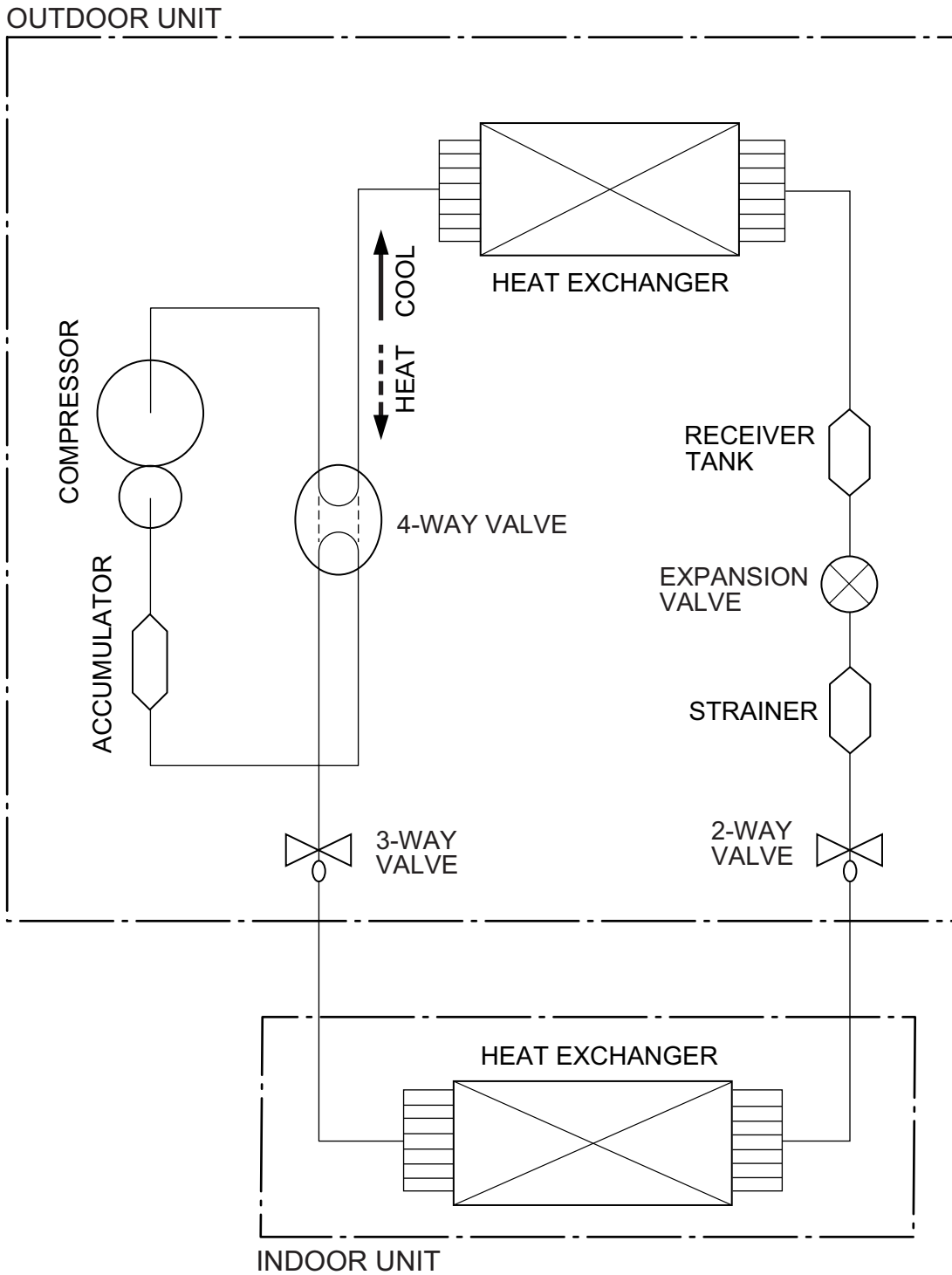

OUTDOOR UNIT

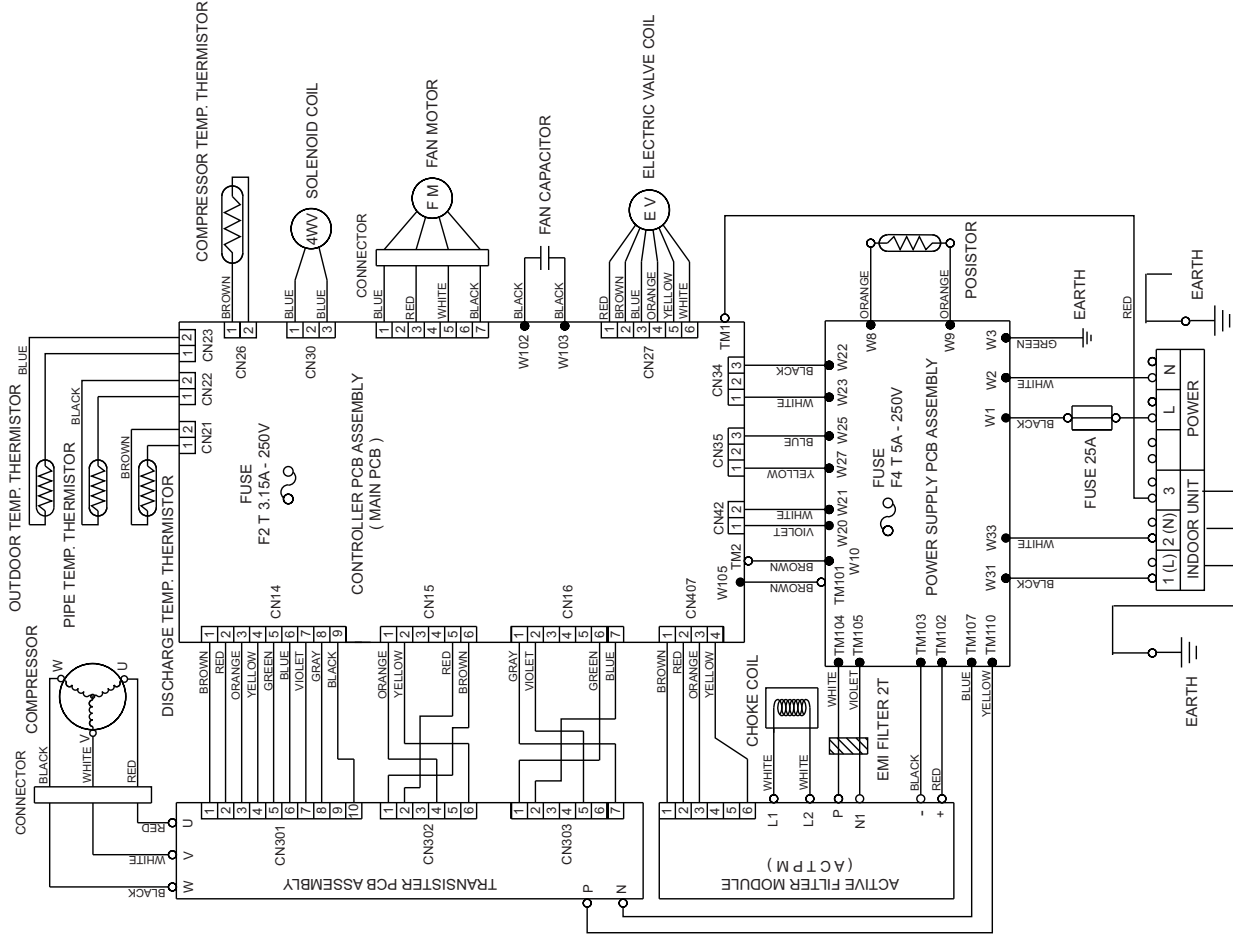

CIRCUIT DIAGRAM

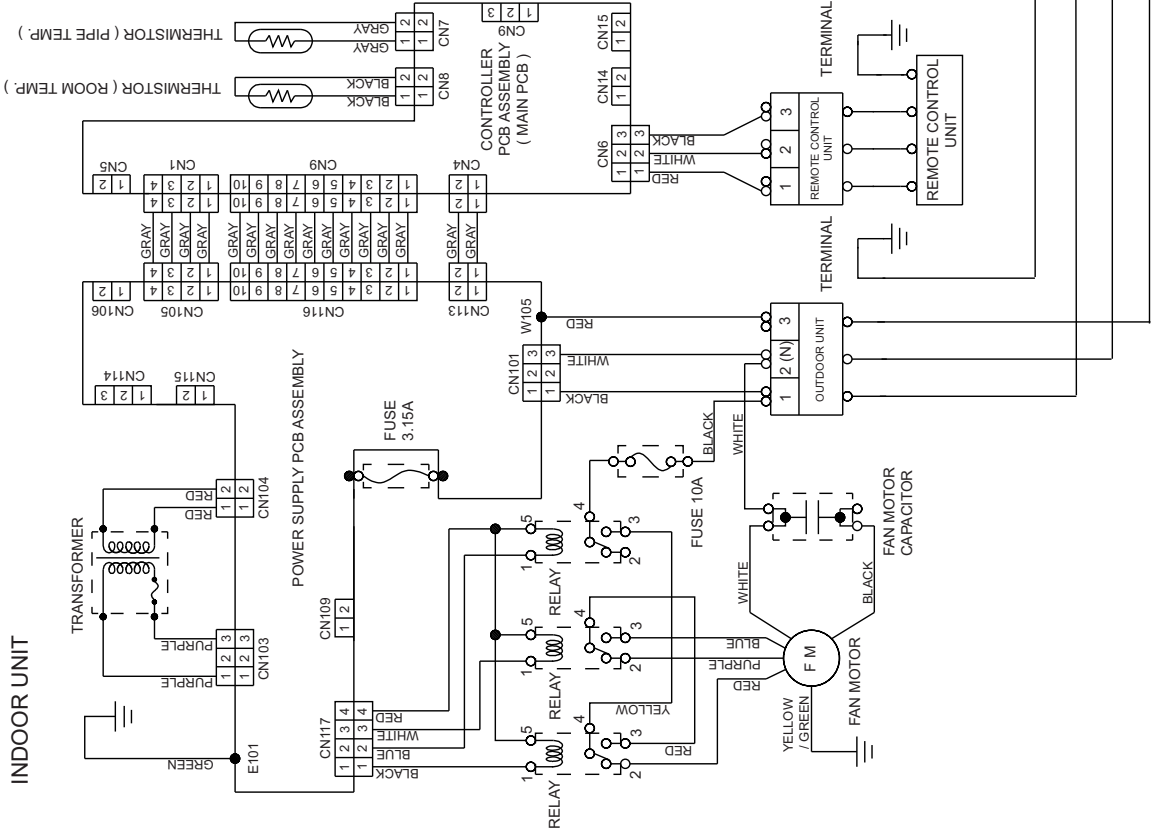

# INDOOR PCB CIRCUIT DIAGRAM

CONTROLLER PCB ASSEMBLY  
 ART30LUAK : K03BZ-0400HSE-C1  
 ART36LUAK : K03BZ-0401HSE-C1  
 ARTC36LATU : K03BZ-0701HSE-C1

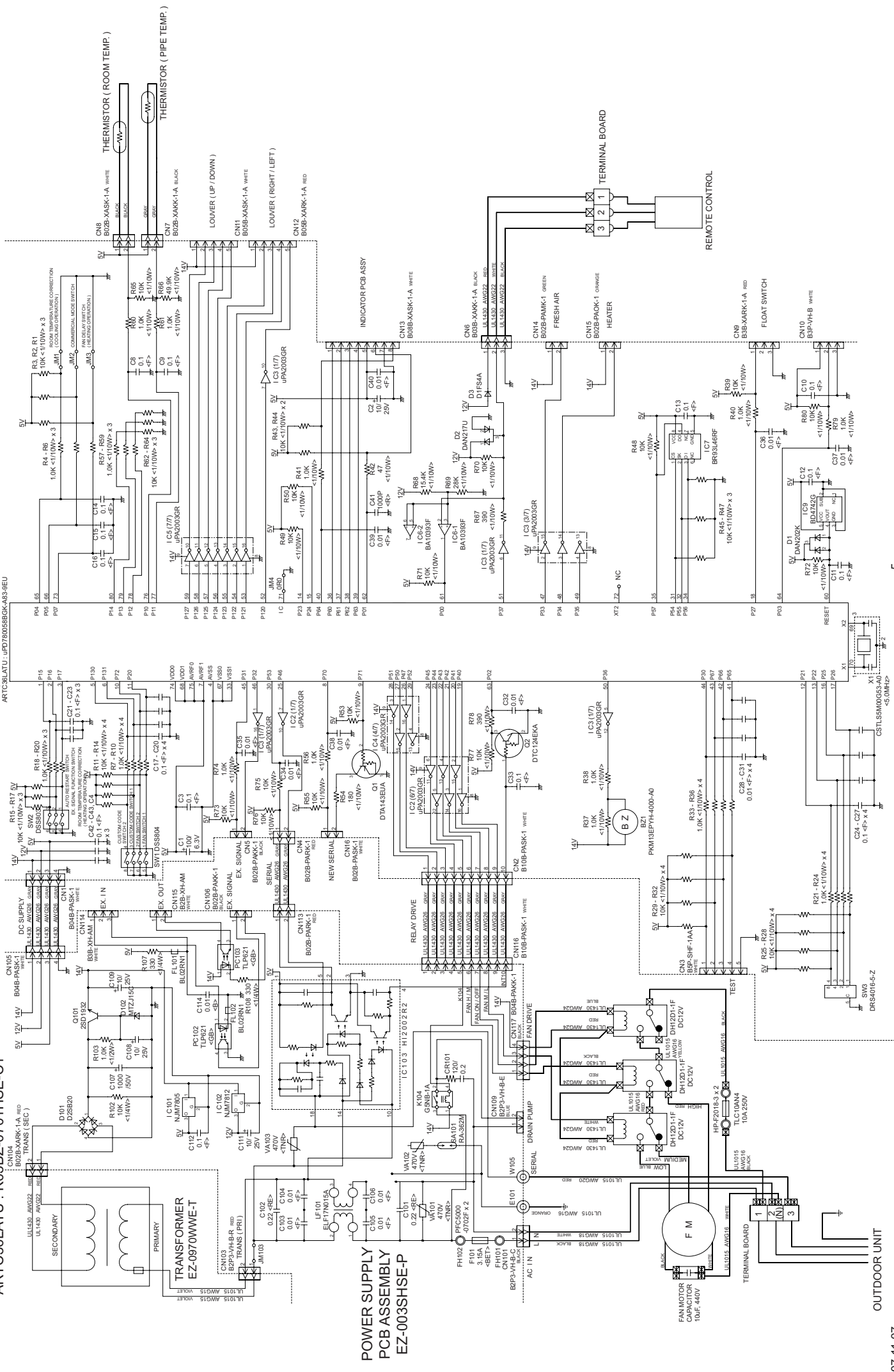

# OUTDOOR PCB CIRCUIT DIAGRAM

INVERTER ASSEMBLY  
AOT30LMBDL : EZ-0040HUE  
AOT36LMADL : EZ-0041HUE

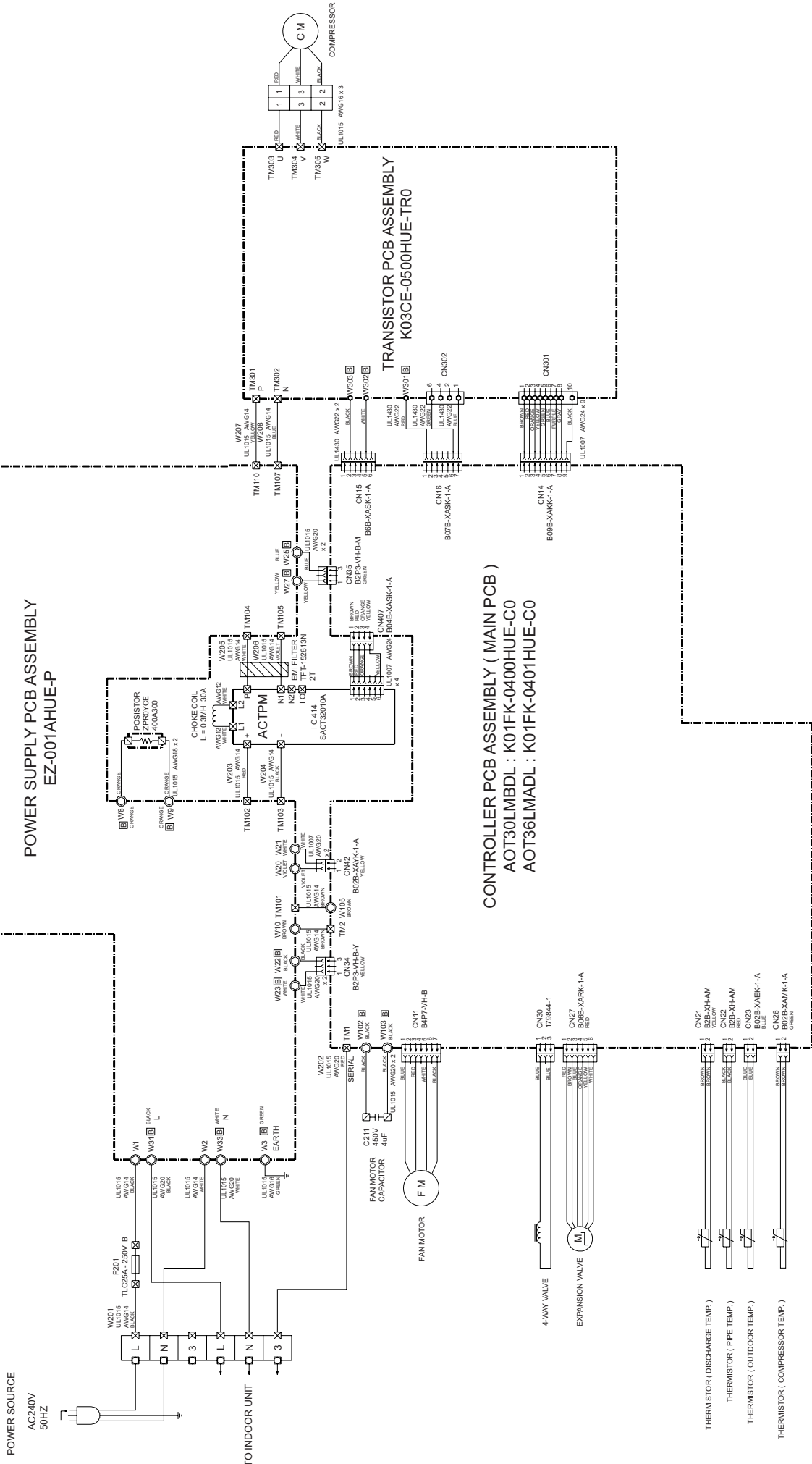

OUTDOOR UNIT  
 CONTROLLER PCB ASSEMBLY ( MAIN PCB )  
 AOT30LMBDL : K01FK-0400HUE-C0  
 AOT36LMADL : K01FK-0401HUE-C0

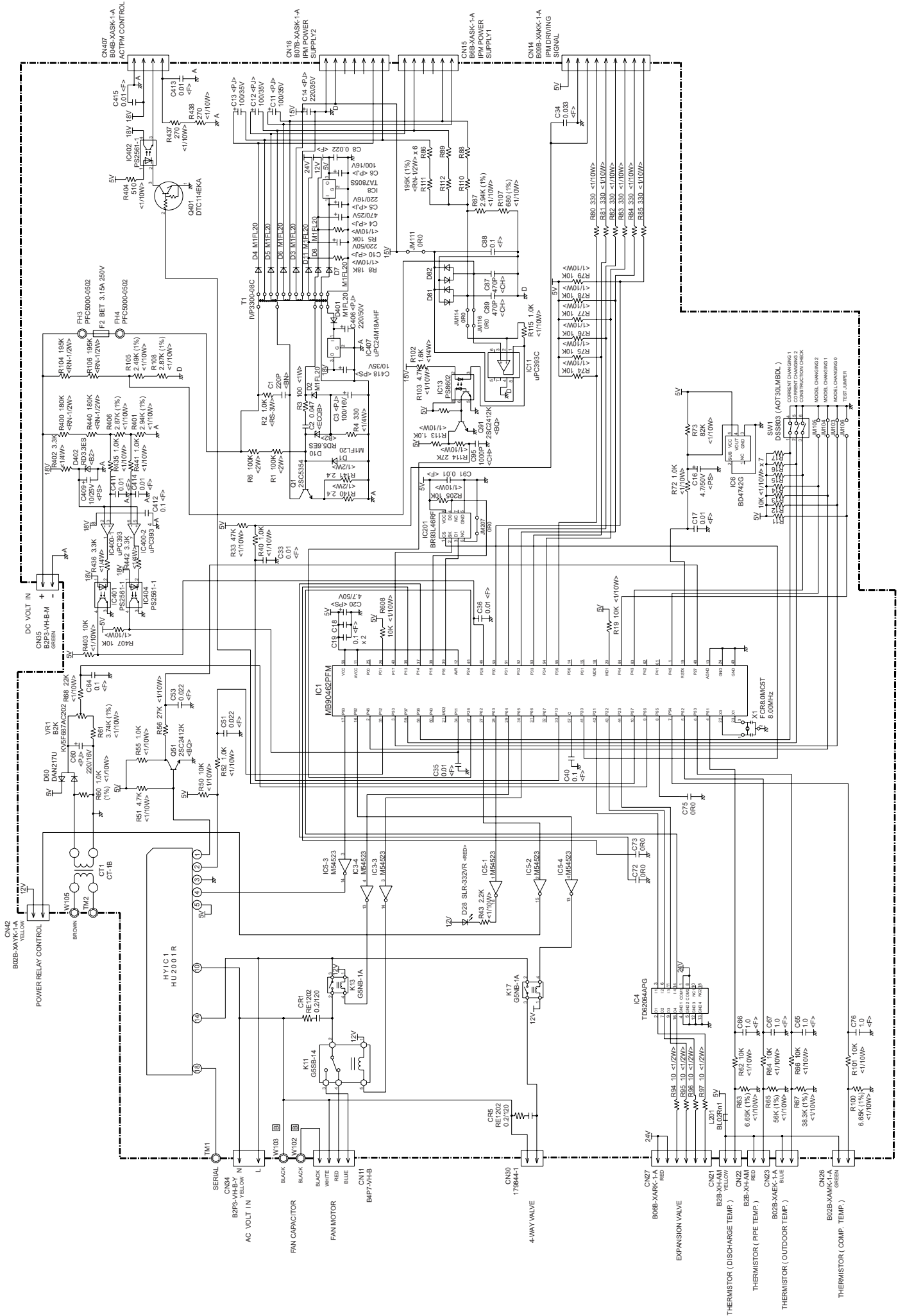



**OUTDOOR UNIT  
POWER SUPPLY PCB ASSEMBLY  
EZ-001AHUE-P**

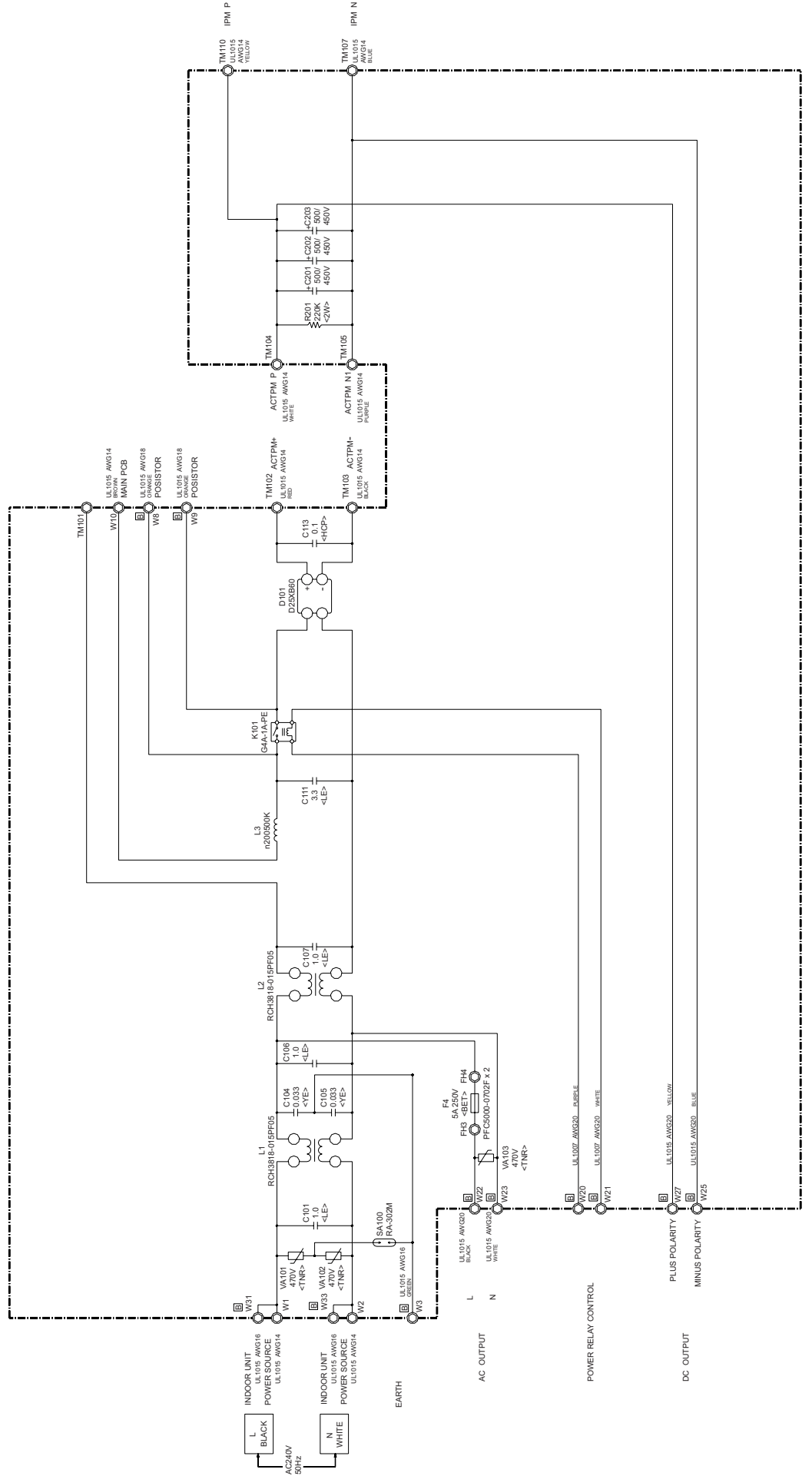

OUTDOOR UNIT  
 TRANSISTOR PCB ASSEMBLY  
 K03CE-0500HUE-TR0

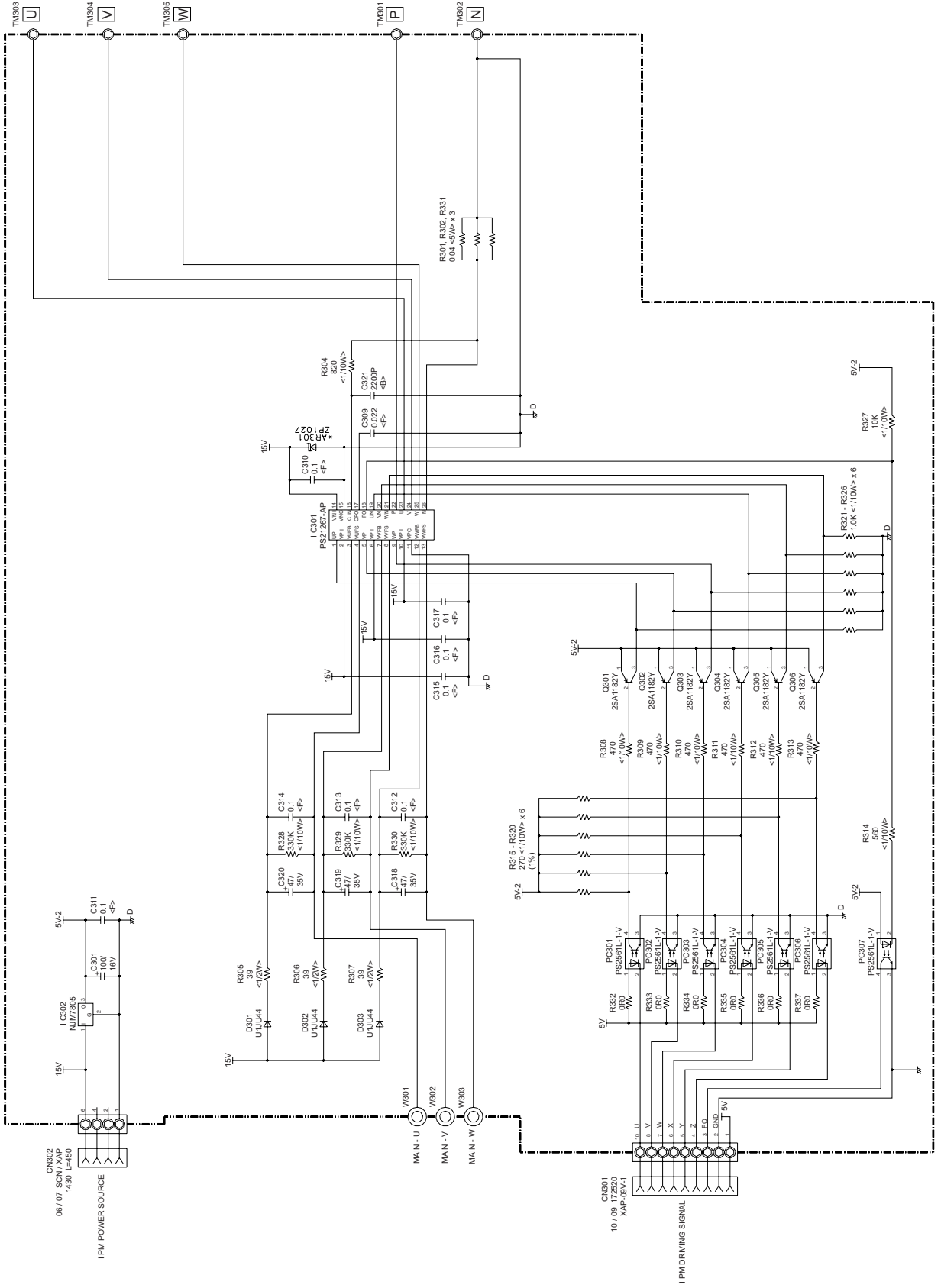

# DIP-SWITCH SETTING

## INDOOR UNIT

	NO.	SW state		Detail
		OFF	ON	
SW1 DIP-Switch	1	—	⤵	Out of Use
	2	—	⤵	
	3	—	⤵	
	4	—	⤵	

	NO.	SW state		Detail	
		OFF	ON		
SW2 DIP-Switch	1	+4	⤵	Room temp correction setting for heating	
	2	Edge	⤵	Pulse	Control input setting
	3	Validity	⤵	Invalidity	Auto restart setting

	NO.	SW state		Detail	
		Connect	Disconnect		
Jumper wire	JM1	0	⤵	+2	Room temp correction setting for cooling
	JM2	Residencial	⤵	Commercial	Commercial mode setting
	JM3	Nomal	⤵	Heater setting	Heater setting

## REMOTE CONTROL

	NO.	SW state		Detail		
		OFF	ON			
DIP-Switch	1			⤵	Dual remote controller setting	
	2		⤵			
	3	One Unit	⤵	Multiple Unit	Group control setting	
	4	Heat & Cool model		Cooling Only model	Model setting	
	5	Invalidity		Validity	⤵	Auto changeover setting
	6	Invalidity	⤵	Validity		Memory backup setting

	NO.	SW state		Detail	
		Connect	Disconnect		
Jumper wire	J5	3 speed (HI,MED,LO)	⤵	1 speed (HI)	Fan speed setting(for AR90)

⤵ Factory setting

## OUTDOOR UNIT

If the breaker is tripped during the test operation due to insufficient current capacity, change the DIP switches on the circuit board to the settings shown in the following table.

DIP-SW			CURRENT (MAX.)
1	2	3	
OFF	OFF	OFF	17.5 A *1
ON	OFF	OFF	15.0 A *2
OFF	ON	OFF	13.0 A
ON	ON	OFF	10.5 A

\*1 = 36,000 BTU model's Factory setting

\*2 = 30,000 BTU model's Factory setting

⚠ CAUTION
<b>Never set the 30,000 BTU model to the maximum current of 17.5 A. The protection devices will be activated and the unit will not operate properly.</b>
<b>If the maximum current is reduced, cooling or heating performance will be reduced.</b>

# ERROR DISPLAY

**CAUTION**

**Always turn on the power 4 hours prior to the start of the operation in order to ensure compressor protection**

- (1) Stop the air conditioner operation.
- (2) Press the master control button and the fan control button simultaneously for 2 seconds or more to start the test run.

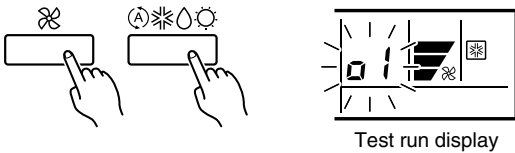

- (3) Press the start/stop button to stop the test run.

## [SELF-DIAGNOSIS]

When the error indication E:EE is displayed, follow the following items to perform the self-diagnosis. E:EE indicates an error has occurred.

### 1. REMOTE CONTROL DISPLAY

- 1) Stop the air conditioner operation.
- 2) Press the set temperature buttons  $\wedge$  /  $\vee$  simultaneously for 5 seconds or more to start the self-diagnosis. Refer to the following tables for the description of each error code.

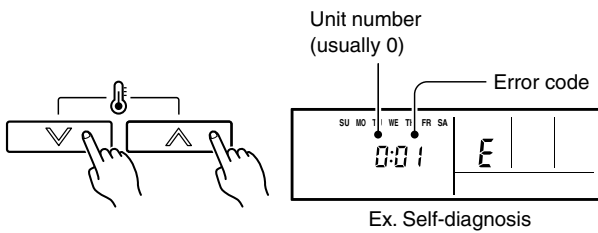

- (3) Press the set temperature buttons  $\wedge$  /  $\vee$  simultaneously for 5 seconds or more to stop the self-diagnosis.

Error code	Error contents
<b>00</b>	Communication error (indoor unit $\leftrightarrow$ remote controller)
<b>01</b>	Communication error (indoor unit $\leftarrow$ outdoor unit)
<b>02</b>	Room temperature sensor open
<b>03</b>	Room temperature sensor short-circuited
<b>04</b>	Indoor heat exchanger temperature sensor open
<b>05</b>	Indoor heat exchanger temperature sensor short-circuited
<b>06</b>	Outdoor heat exchanger temperature sensor
<b>08</b>	Power source connection error
<b>09</b>	Float switch operated
<b>0A</b>	Outdoor temperature sensor
<b>0c</b>	Discharge pipe temperature sensor
<b>0E</b>	Outdoor high pressure abnormal
<b>11</b>	Model abnormal
<b>13</b>	Communication error (indoor unit $\rightarrow$ remote controller)
<b>14</b>	
<b>15</b>	Compressor temperature sensor
<b>17</b>	IPM error
<b>1A</b>	Compressor can not start

# PARTS

## INDOOR UNIT

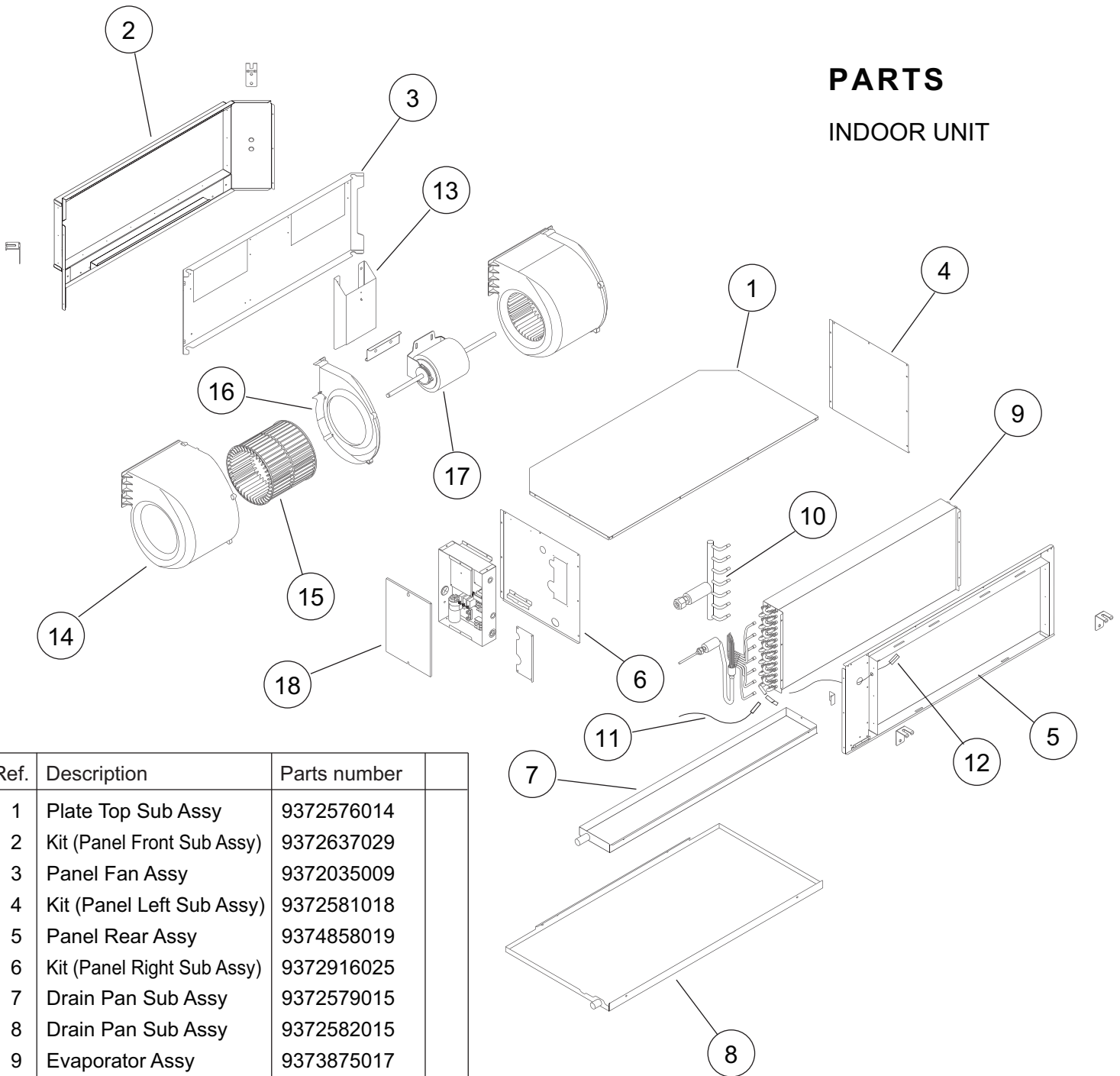

Ref.	Description	Parts number
1	Plate Top Sub Assy	9372576014
2	Kit (Panel Front Sub Assy)	9372637029
3	Panel Fan Assy	9372035009
4	Kit (Panel Left Sub Assy)	9372581018
5	Panel Rear Assy	9374858019
6	Kit (Panel Right Sub Assy)	9372916025
7	Drain Pan Sub Assy	9372579015
8	Drain Pan Sub Assy	9372582015
9	Evaporator Assy	9373875017
10	Distributor Assy	9373873013
11	Pipe Thermistor	9703297113
12	Room Thermistor	9703299216
13	Bracket Motor Assy	9372037003
14	Casing A	9372057018
15	Sirocco Fan	9372059012
16	Casing B	9372058015
17	Fan Motor	9601689027
18	Cover Box	9372061008
--	Motor Mount Assy	9372052006
--	Motor Fixture	9356536003
--	Rubber (Fan Motor)	313659068604
--	Hook	9372055007
--	Remote Control	9372266038

# INDOOR UNIT

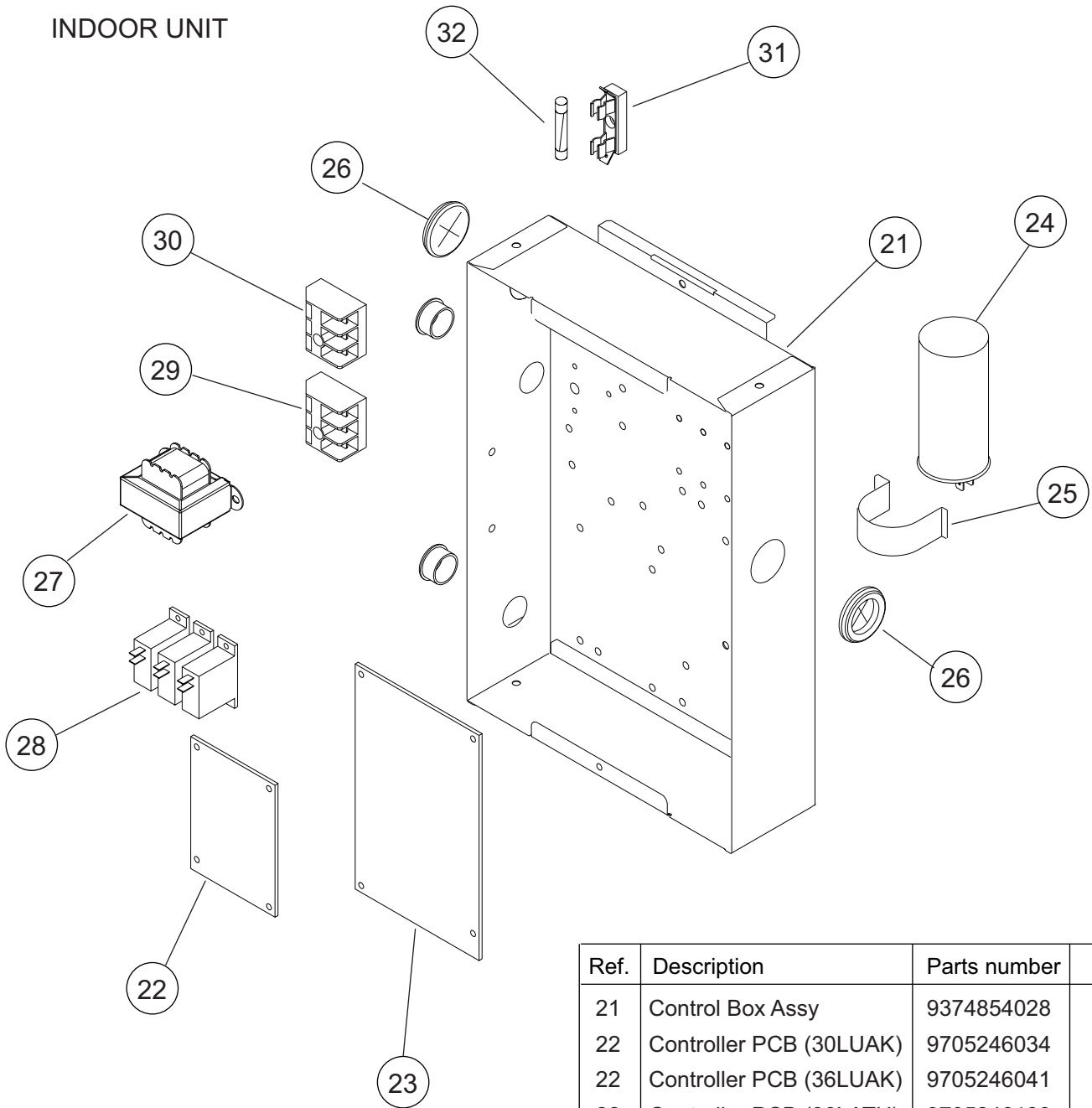

Ref.	Description	Parts number
21	Control Box Assy	9374854028
22	Controller PCB (30LUAK)	9705246034
22	Controller PCB (36LUAK)	9705246041
22	Controller PCB (36LATU)	9705246188
23	Power PCB Assy	9705271012
24	Capacitor Plastic	9900269173
25	Capacitor Clamp	9308114006
26	Cap	9352173011
27	Power Transformer	9704129017
28	Relay	9900294014
29	Terminal 3P	9306489045
30	Terminal 3P	9703345012
31	Fuse Holder	0501454012
32	Fuse	0600384029

# OUTDOOR UNIT

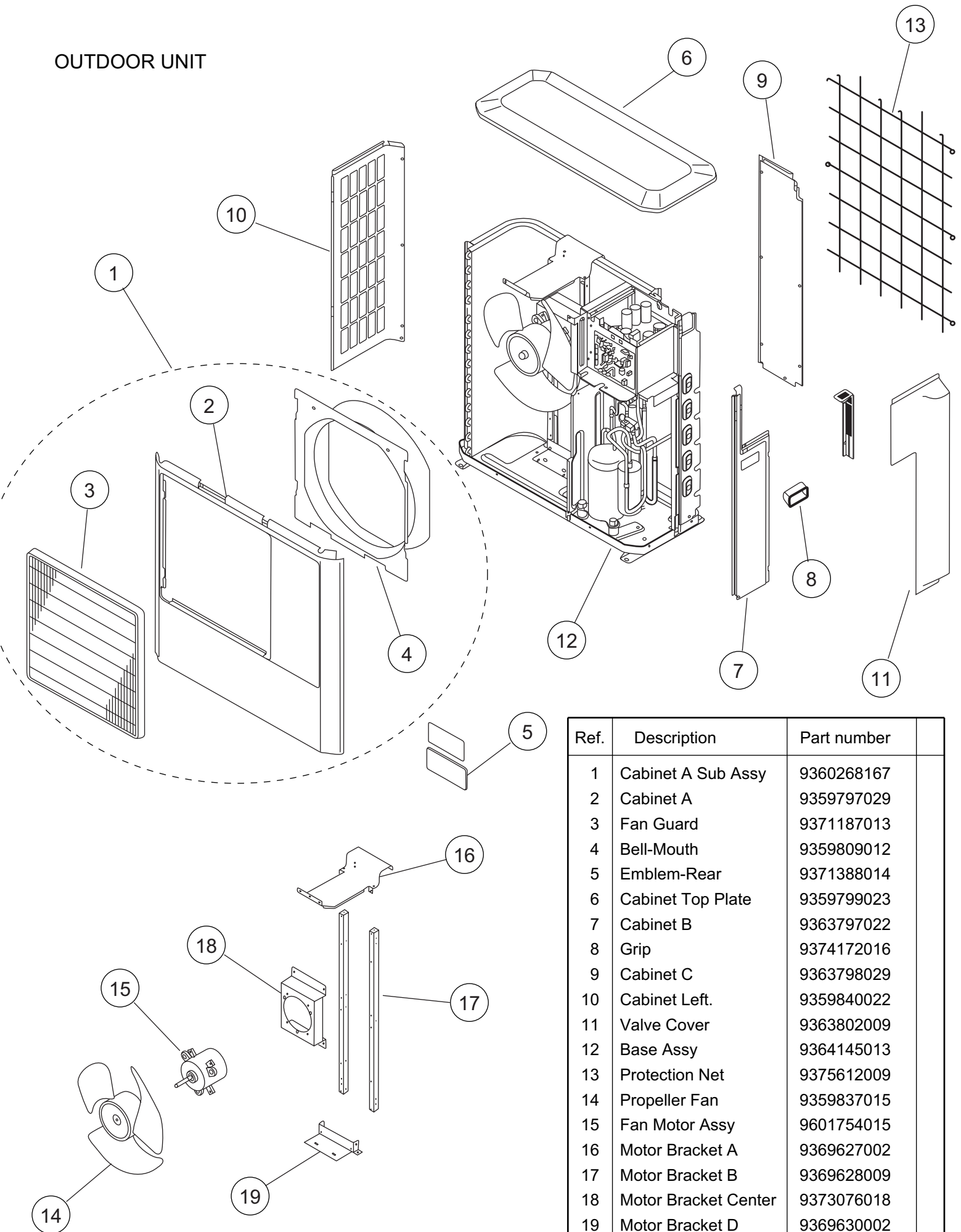

Ref.	Description	Part number
1	Cabinet A Sub Assy	9360268167
2	Cabinet A	9359797029
3	Fan Guard	9371187013
4	Bell-Mouth	9359809012
5	Emblem-Rear	9371388014
6	Cabinet Top Plate	9359799023
7	Cabinet B	9363797022
8	Grip	9374172016
9	Cabinet C	9363798029
10	Cabinet Left.	9359840022
11	Valve Cover	9363802009
12	Base Assy	9364145013
13	Protection Net	9375612009
14	Propeller Fan	9359837015
15	Fan Motor Assy	9601754015
16	Motor Bracket A	9369627002
17	Motor Bracket B	9369628009
18	Motor Bracket Center	9373076018
19	Motor Bracket D	9369630002
--	Drain Assy	9303029015
--	Drain Cap	313166024302

# OUTDOOR UNIT

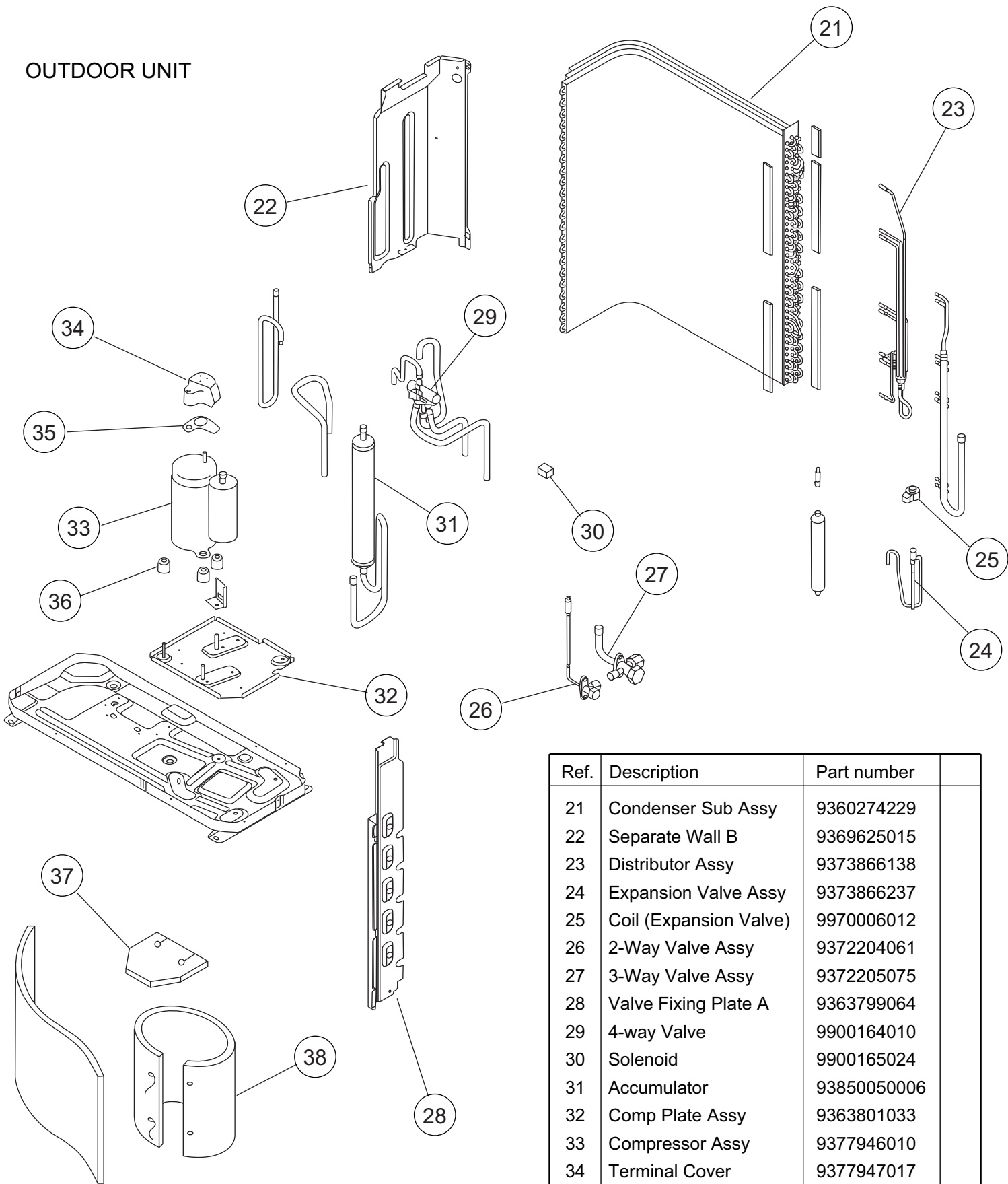

Ref.	Description	Part number
21	Condenser Sub Assy	9360274229
22	Separate Wall B	9369625015
23	Distributor Assy	9373866138
24	Expansion Valve Assy	9373866237
25	Coil (Expansion Valve)	9970006012
26	2-Way Valve Assy	9372204061
27	3-Way Valve Assy	9372205075
28	Valve Fixing Plate A	9363799064
29	4-way Valve	9900164010
30	Solenoid	9900165024
31	Accumulator	93850050006
32	Comp Plate Assy	9363801033
33	Compressor Assy	9377946010
34	Terminal Cover	9377947017
35	Terminal Packing	9377948014
36	Rubber Seat A	9377951014
37	Compressor Cover	9372067017
38	Compressor Cover C	9370186000
--	Rubber Washer	9377949011
--	Strainer B	9365099018
--	Condenser A Assy	9373867012
--	Condenser B Assy	9373867029





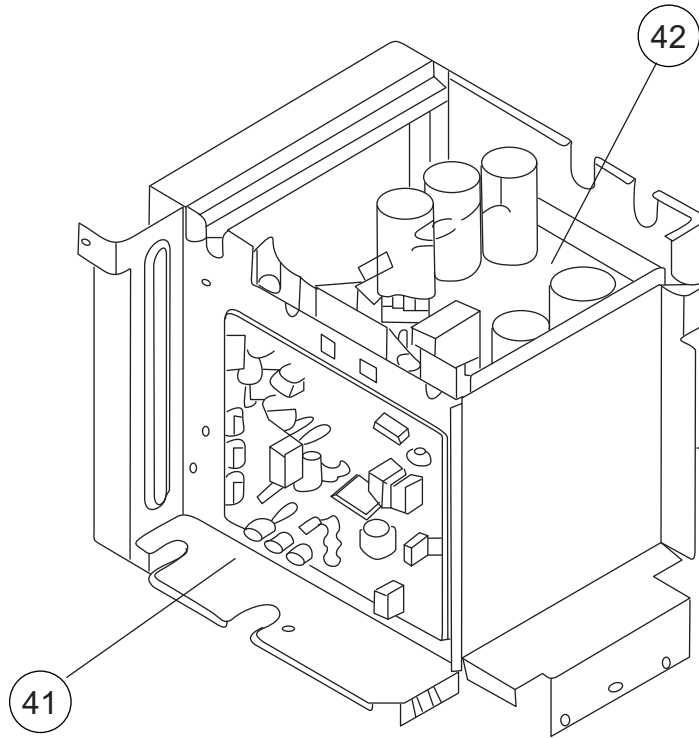



## OUTDOOR UNIT





Ref.	Description	Part number
41	Controller PCB Assy (30)	9704719096
41	Controller PCB Assy (36)	9704719102
42	Power Supply PCB Assy	9704722010
--	ACTPM	9703457012
--	TR PCB Assy	9705253025
--	Heat Exchanger Thermistor	9704220059
--	Outdoor Thermistor	9703516054
--	PTC Thermistor	9704265012
--	Discharge Thermistor	9704219077
--	Terminal-6P	9900203030
--	Reactor Cover	9369622007
--	Heat Sink-A	9369792007
--	Heat Sink-B	9369793004
--	Compressor Thermistor	9900156015

## STANDARD ACCESSORIES

### INDOOR UNIT

Name and Shape	Q'ty	Application	Part number
Special nut A (large flange) 	4	For suspending the indoor unit from ceiling	313005446653
Special nut B (small flange) 	4		313005446759
Coupler heat insulation (large) 	1	For indoor side pipe joint (large pipe)	9350716029
Coupler heat insulation (small) 	1	For indoor side pipe joint (small pipe)	9352766015
Nylon fastener 	1	For fixing the drain hose	313361275805
Remote control 	1		9372266038
Tapping screw (flush heads) 	2	For installing the remote control unit	0700181108

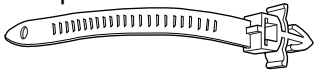
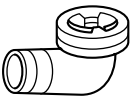
### OUTDOOR UNIT

Name and Shape	Part No.
Hexagon wrench 	9351228019
Cable clip 	313739340109
Drain pipe 	9303029015
Drain cap 	313166024302
Putty 	303020200114

0404G2577