

## **Creative Sound Blaster Live! Creative Audio Software**

Information in this document is subject to change without notice and does not represent a commitment on the part of Creative Technology Ltd. No part of this manual may be reproduced or transmitted in any form or by any means, electronic or mechanical, including photocopying and recording, for any purpose without the written permission of Creative Technology Ltd. The software described in this document is furnished under a license agreement and may be used or copied only in accordance with the terms of the license agreement. It is against the law to copy the software on any other medium except as specifically allowed in the license agreement. The licensee may make one copy of the software for backup purposes.

Copyright © 1998-2003 Creative Technology Ltd. All rights reserved.

Version 1.5

September 2003

Sound Blaster and Blaster are registered trademarks, and the Sound Blaster Live! logo, the Sound Blaster PCI logo, EAX and Creative Multi Speaker Surround are trademarks of Creative Technology Ltd. in the United States and/or other countries. E-Mu and SoundFont are registered trademarks of E-mu Systems, Inc.. Cambridge SoundWorks, MicroWorks and PC Works are registered trademarks, and PC Works FourPointSurround is a trademark of Cambridge SoundWorks, Inc.. Microsoft, MS-DOS, and Windows are registered trademarks of Microsoft Corporation. Manufactured under license from Dolby Laboratories. "Dolby", "Pro Logic" and the double-D symbol are trademarks of Dolby Laboratories. Confidential unpublished works. Copyright 1992-1997 Dolby Laboratories. All rights reserved. All other products are trademarks or registered trademarks of their respective owners.

This product is covered by one or more of the following U.S. patents:

4,506,579; 4,699,038; 4,987,600; 5,013,105; 5,072,645; 5,111,727; 5,144,676; 5,170,369; 5,248,845; 5,298,671; 5,303,309; 5,317,104; 5,342,990; 5,430,244; 5,524,074; 5,698,803; 5,698,807; 5,748,747; 5,763,800; 5,790,837.

# Contents

---

## Introduction

System Requirements .....	ii
Sound Blaster Live! card .....	ii
Games and DVD viewing .....	ii
Getting More Information .....	ii
Document Conventions .....	iii

## I Installing Hardware

What You Need .....	1-1
Your Sound Blaster Live! Card .....	1-2
Step 1: Prepare your computer .....	1-3
Step 2: Install the Sound Blaster Live! card .....	1-4
Step 3: Install the CD-ROM/DVD-ROM drive .....	1-5
Step 4: Connect to power supply .....	1-6
Enabling CDDA .....	1-6
Connecting Related Peripherals .....	1-8
Connecting Speaker Systems .....	1-9
Connecting external consumer electronic devices .....	1-10
Positioning Your Speakers .....	1-11

## 2 Installing Software

Installing Drivers and Applications .....	2-1
---	-----

## 3 Using Sound Blaster Live!

Creative Software .....	3-1
Creative Surround Mixer .....	3-2
Creative AudioHQ .....	3-2

Creative Diagnostics .....	3-3
SoundFont Control.....	3-3
Creative Keyboard .....	3-3
EAX Control.....	3-3
Creative Wave Studio.....	3-4
Creative PlayCenter .....	3-4
Creative Recorder.....	3-4

## **A General Specifications**

Features.....	A-1
PCI Bus Mastering.....	A-1
EMU10K1 .....	A-1
Stereo Digitized Voice Channel .....	A-1
AC '97 Codec Mixer .....	A-2
Volume Control.....	A-2
Dolby Digital (AC-3) Decoding.....	A-2
Creative Multi Speaker Surround (CMSS).....	A-2
Connectivity .....	A-3
Audio Inputs.....	A-3
Audio Outputs.....	A-3
Interfaces .....	A-3

## **B Troubleshooting**

Problems Installing Software.....	B-1
Sound .....	B-2
Problems with File Transfers on Some VIA Chipset Motherboards.....	B-5
Insufficient SoundFont Cache .....	B-6
Joystick .....	B-6
I/O Conflicts .....	B-7
Problems in Windows XP.....	B-8

# Introduction

---

Sound Blaster Live! is an audio solution for games, movies, CDs, MP3 music, and Internet entertainment. With its support for today's leading audio standard—EAX—Sound Blaster Live! creates real-life, multi-dimensional sound and multi-textured acoustical environments for the most realistic 3D audio experience. Its powerful EMU10K1 audio processor delivers audio at optimum CPU performance with the highest fidelity and absolute clarity. Combine it with a four- or five-speaker setup and you'll experience realistic 3D audio, EAX in supported games, and enjoy your movies with true surround sound.

## System Requirements

### Sound Blaster Live! card

- Genuine Intel® Pentium® II 350 MHz, AMD® K6 450 MHz or faster class processor
- Intel, AMD or 100%-Intel compatible motherboard chipset
- Windows 98 Second Edition (SE), Windows Millennium Edition (Me), Windows 2000 or Windows XP
- 64 MB RAM for Windows 98 SE/Me  
128 MB RAM for Windows 2000/XP
- 600 MB of free hard disk space
- Available PCI 2.1 compliant slot for the Sound Blaster Live! card
- Headphones or amplified speakers (available separately)
- CD-ROM drive installed

### Games and DVD viewing

- Genuine Intel Pentium II 350 MHz, MMX or AMD 450 MHz processor/3Dnow!
- Games: 128 MB RAM recommended, 3D graphics accelerator with at least 8 MB of texture RAM, available 300–500 MB of free hard disk space
- DVD: A second generation or later DVD-ROM drive with these recommended soft-DVD players: InterVideo's WinDVD2000 or CyberLink's PowerDVD 3.0 or later

Sound Blaster Live! estimates the hard disk space required when you select it during installation. Other applications may have higher system requirements or may require a microphone. Refer to the individual application's online Help for details.

### Getting More Information



See the online *User's Guide* for MIDI specifications and connector pin assignments, as well as instructions on using the various applications in your audio package.

Visit <http://www.creative.com> for the latest drivers, applications and FAQs.

# Document Conventions

This manual uses the following conventions to help you locate and identify the information that you need.

**Table i: Document conventions.**

Text Element	Use
 A blue notepad with a red pencil and a red starburst above it, indicating importance.	This notepad icon indicates information that is of particular importance and should be considered before continuing.
 A black alarm clock with a white bell and a white exclamation mark inside, indicating a warning.	This alarm clock icon indicates that failure to adhere to directions may result in loss of data or damage to your system.
 A red triangular warning sign with a black exclamation mark inside, indicating a serious warning.	The warning sign indicates that failure to adhere to directions may result in bodily harm or life-threatening situations.

## Installing Hardware

### What You Need



Appearance may differ depending on model and region of purchase. Some connectors shown here may only be available with certain cards.

Before you begin installation, be sure that you have these:

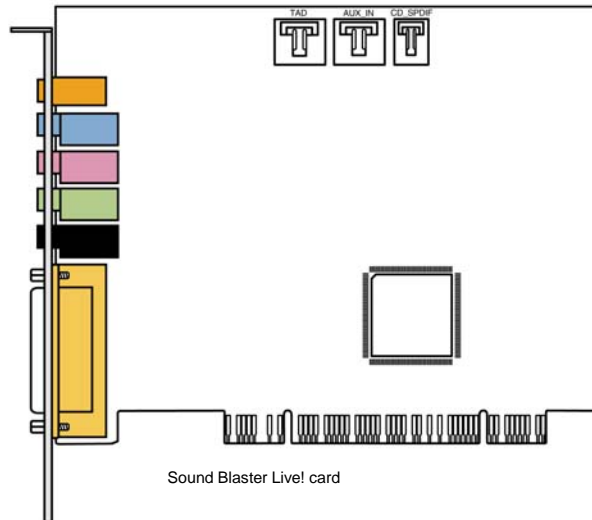

MPC-to-MPC (4-pin) Analog CD audio cable\*



MPC-to-MPC (2-pin) Digital CD audio cable\*



Phillips Screwdriver (not included)

\*Available with some models of Sound Blaster Live! card.

# Your Sound Blaster Live! Card



Appearance may differ depending on model and region of purchase. Some connectors shown here may only be available with certain cards.

Your audio card has these connectors which allow you to attach other devices:

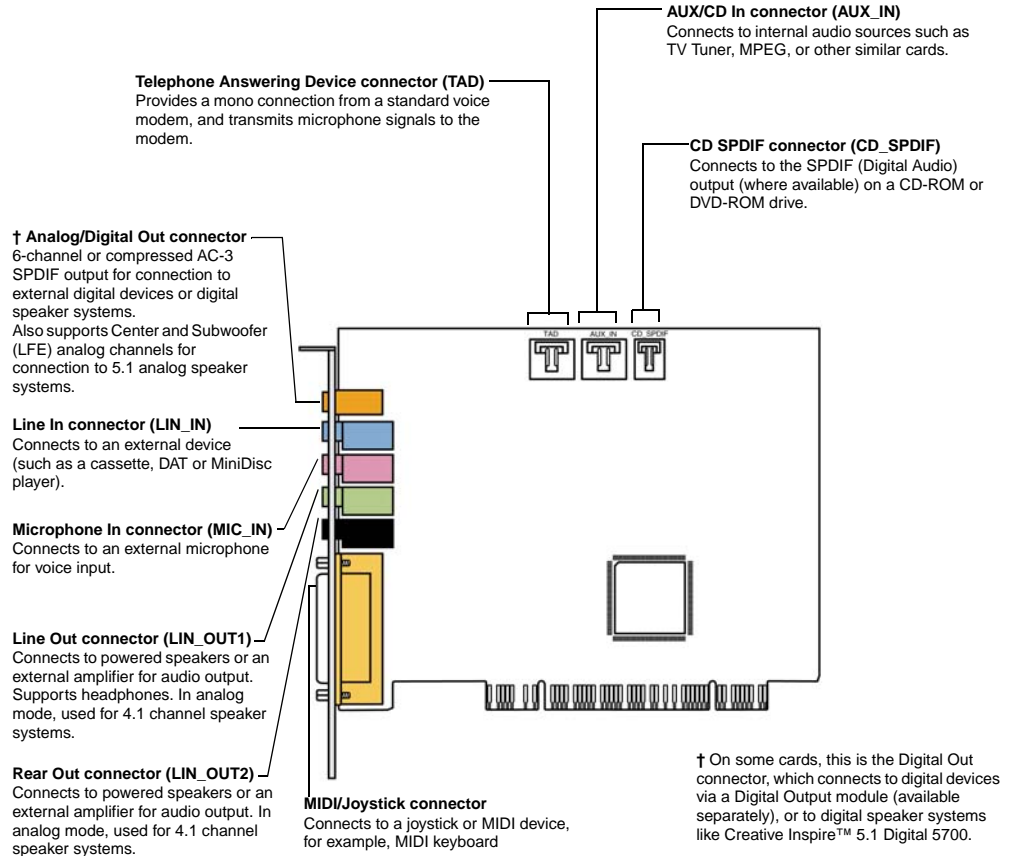

Figure 1-1: Connectors on the Sound Blaster Live! card.



## Step 1: Prepare your computer



Turn off the main power supply and disconnect your computer's power cord. Systems using an ATX power supply unit with soft power off may still be powering the PCI slot. This can damage your audio card when it is inserted into the slot.



Remove any existing audio card or disable the onboard audio. Refer to the manufacturer's documentation for details.

1. Turn off your computer and all peripheral devices.
2. Touch a metal plate on your computer to ground yourself and to discharge any static electricity, and then unplug the power cord from the wall outlet.
3. Remove the computer cover.
4. Remove the metal bracket from an unused PCI slot as shown in Figure 1-2.

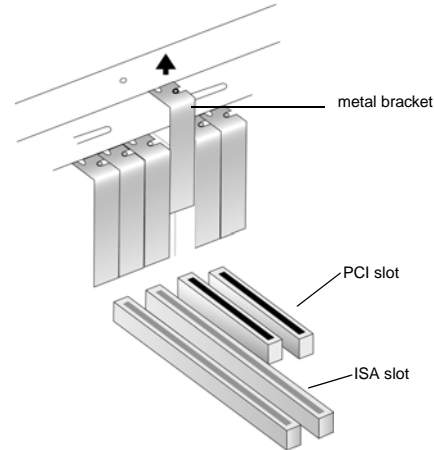

Figure 1-2: Removing a metal bracket.

## Step 2: Install the Sound Blaster Live! card



Do not force the audio card into the slot. Make sure that the gold connectors on the Sound Blaster Live! card are aligned with the PCI bus connector on the motherboard before you insert the card into the PCI expansion slot.

If it does not fit properly, gently remove it and try again, or try the card in a different PCI slot.

1. Align the Sound Blaster Live! card with the PCI slot and press the card gently but firmly into the slot as shown in Figure 1-3.

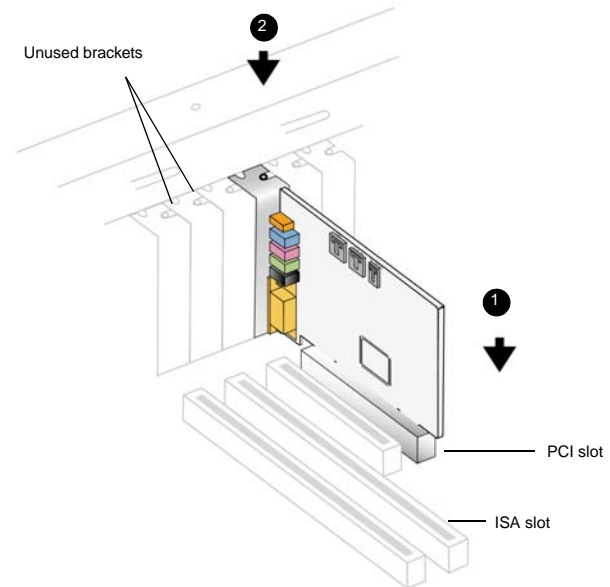

Figure 1-3: Aligning the card against the slot.

2. Secure the Sound Blaster Live! card.

## Step 3: Install the CD-ROM/DVD-ROM drive



- The MPC-to-MPC (4-pin) Analog CD audio cable is available only with some models of the Sound Blaster Live! card.
- If the Sound Blaster Live! card is connected to both the CD SPDIF and CD Audio connectors on a CD-ROM or DVD-ROM drive, do not enable the CD Audio and CD Digital options at the same time in Surround Mixer.
- You may experience a decrease in audio quality when you use the AUX\_IN connector for analog audio. Use CDDA instead for high quality audio playback.

With Compact Disc Digital Audio (CDDA) extraction enabled for your computer's operating system, you do not have to use an audio cable to connect your drive to your audio card.

For information on how to enable CDDA, see “Enabling CDDA” on page 1-6.

If you cannot enable CDDA on your computer, you should use an audio cable to connect your drive to your audio card as shown below.

For analog CD audio output:

- ▶ Connect an Analog CD audio cable from the Analog Audio connector on your CD-ROM/DVD-ROM drive to the AUX\_IN connector on the Sound Blaster Live! card as shown in Figure 1-4.

For digital CD audio output (available on some cards):

- ▶ Connect the Digital CD audio cable from the Digital Audio connector on your CD-ROM/DVD-ROM drive to the CD\_SPDIF connector on the Sound Blaster Live! card.

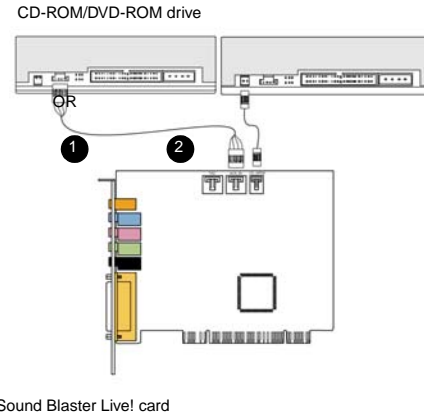

Figure 1-4: Connecting CD-ROM/DVD-ROM drives.

## Step 4: Connect to power supply

1. Replace the computer cover.
2. Plug the power cord back into the wall outlet, and turn on the computer.

To connect your Sound Blaster Live! card to other devices, see “Connecting Related Peripherals” on page 1-8.

To install drivers and software, refer to “Installing Drivers and Applications” on page 2-1.

## Enabling CDDA

### For Windows 98 SE

1. Click **Start** -> **Settings** -> **Control Panel**.
2. In the **Control Panel** window, double-click the **Multimedia** icon.
3. In the **Multimedia Properties** dialog box, click the **CD Music** tab.
4. Click the **Enable digital CD audio for this CD-ROM device** check box to select it.
5. Click the **OK** button.

### For Windows Me

1. Click **Start** -> **Settings** -> **Control Panel**.
2. In the **Control Panel** window, double-click the **System** icon.
3. In the **System Properties** dialog box, click the **Device Manager** tab.
4. Double-click the **DVD/CD-ROM drives** icon.  
Your computer drives will appear.
5. Right-click the disk drive icon. A menu will appear.
6. Click **Properties**.
7. In the **Digital CD Playback** box of the next dialog box, click the **Enable digital CD audio for this CD-ROM device** check box to select it.
8. Click the **OK** button.

### For Windows 2000 and Windows XP

1. Click **Start** -> **Settings** -> **Control Panel**.

2. In the **Control Panel** window, double-click the **System** icon.
3. In the **System Properties** dialog box, click the **Hardware** tab.
4. Click the **Device Manager** button.
5. Double-click the **DVD/CD-ROM drives** icon.  
Your computer drives will appear.
6. Right-click the disk drive icon. A menu will appear.
7. Click **Properties**.
8. In the **Digital CD Playback box** of the next dialog box, click the **Enable digital CD audio for this CD-ROM device** check box to select it.

# Connecting Related Peripherals



The joystick connector is a standard computer game control adapter. You can connect any analog joystick with a 15-pin D-shell connector or any device compatible with the standard PC joystick. To use two joysticks, you need a Y-cable splitter.

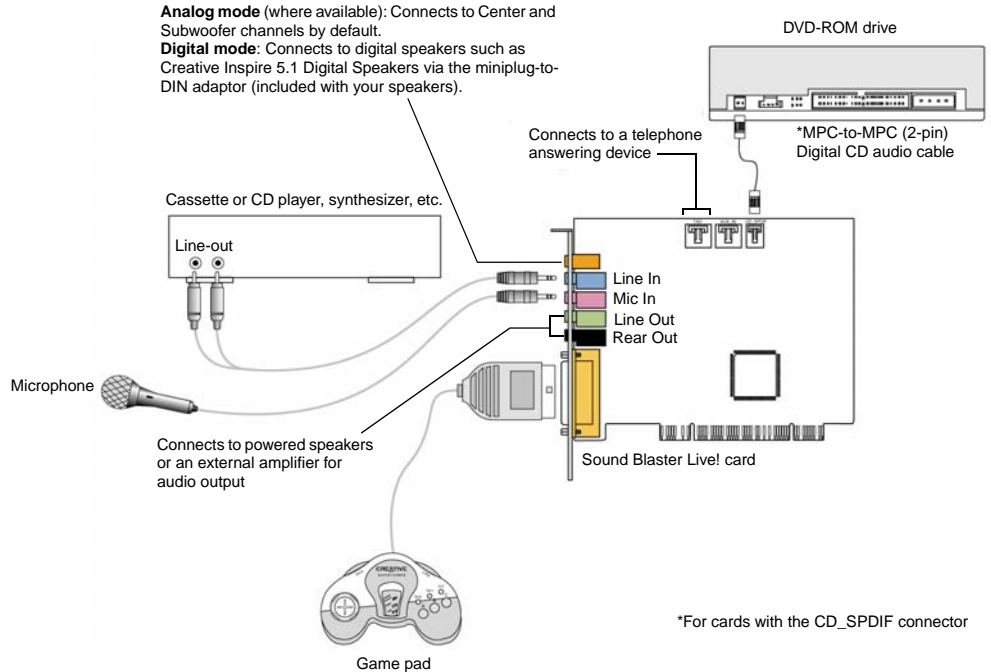

Figure 1-5: Connecting Sound Blaster Live! to other devices.

# Connecting Speaker Systems

Use a software DVD player with Sound Blaster Live! to watch movies with 5.1-channel surround sound. For analog sound, connect your audio card to a Creative Inspire 5.1 speaker system. Otherwise, use a Creative Inspire 5.1 Digital speaker system.

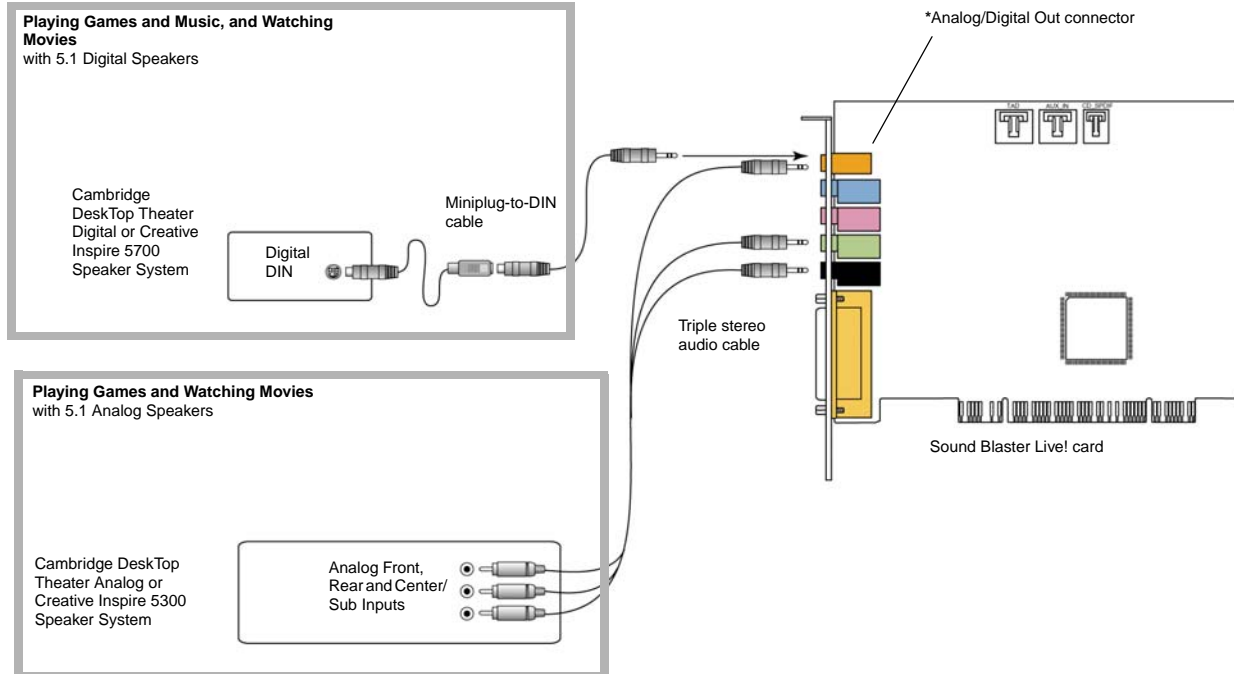

Figure 1-6: Connecting speakers to the Sound Blaster Live! card.

# Connecting external consumer electronic devices

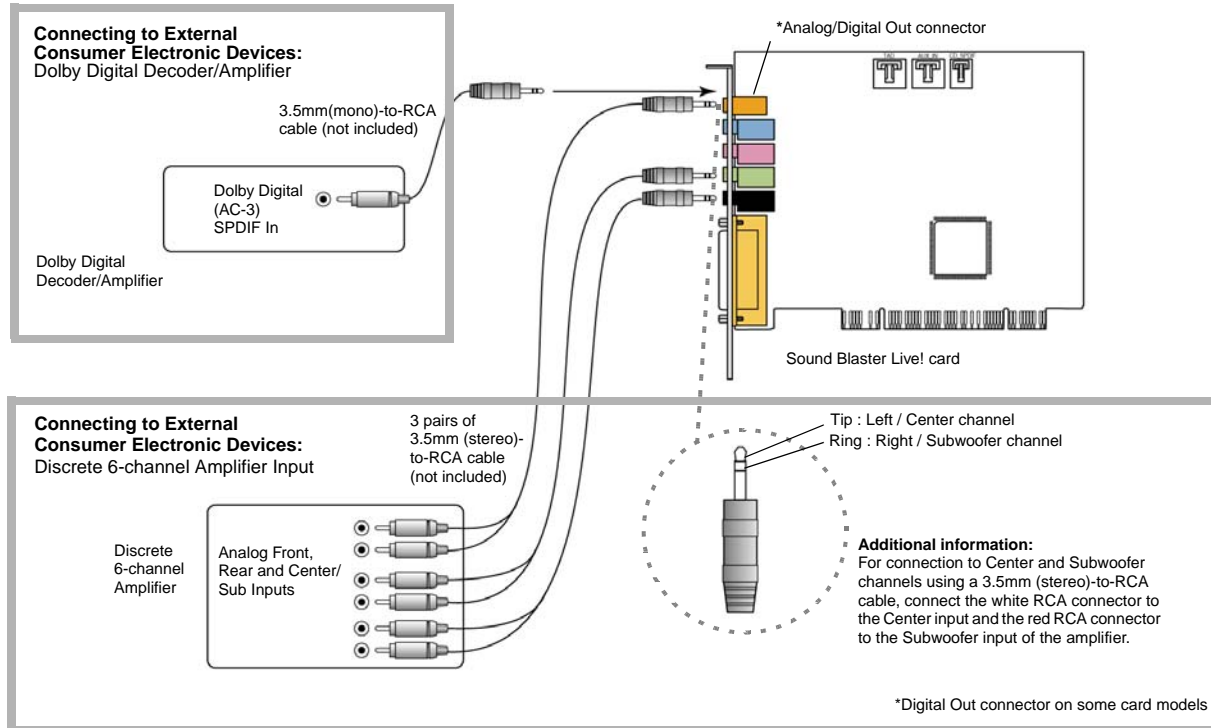

Figure 1-7: Connecting external consumer electronic devices to the Sound Blaster Live! card.



## Positioning Your Speakers

If you are using four speakers, place them to form the corners of a square with you in the center. Angle the speakers toward you with the computer monitor positioned to not block the sound path of your front speakers. For 5.1 speaker systems, the Center speaker should be placed at ear level or as close to ear level as possible. Adjust the positions of the speakers until you get the best audio experience. If you have a subwoofer, place the unit in a corner of the room.

With Cambridge DeskTop Theater 5.1 or Creative Inspire 5.1 Digital Speakers, you can experience crystal clear gaming sequences or music from the Digital DIN connection. A minijack-to-DIN cable is bundled with the speaker set for this connection.

Or, where applicable, connect an analog 5.1 channel speaker system (such as Creative Inspire 5.1 Analog Speakers) or your 6-channel home theater speaker system. Sound Blaster Live! allows you to connect center and subwoofer speakers.

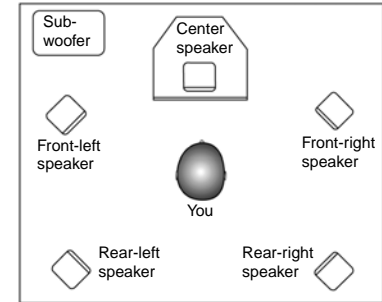

Figure 1-8: Recommended speaker positions.

# Installing Software

---

## Installing Drivers and Applications



This manual reflects a software installation in an unmodified version of the operating system. Your installation screens and procedure may vary slightly from what is shown and described. The variations may be caused by other software/hardware installed on your computer, or the version of the Windows operating system.

Prior to using Sound Blaster Live!, you will need to install device drivers and supporting applications. To install these drivers and the bundled applications, use the following instructions. The instructions are applicable to all supported Windows operating systems.

1. After you have installed the Sound Blaster Live! card, turn on your computer. Windows automatically detects the audio card and device drivers. If the **New Hardware Found** dialog box appears, click the **Cancel** button.
2. Insert the Sound Blaster Live! Installation CD into your CD-ROM drive. The disc supports Windows AutoPlay mode and starts running automatically. If not, you need to enable your CD-ROM drive's auto-insert notification feature. For more details, see "Problems Installing Software" on page B-1.
3. Follow the instructions on the screen to complete the installation.
4. When prompted, restart your system.

# Using Sound Blaster Live!

---

## Creative Software



The applications included with Sound Blaster Live! may differ from the ones described here.

Sound Blaster Live! is supported by a full range of applications to help you get the most from your audio card. The following software is most important to the operation of your audio card:

- Creative Surround Mixer
- Creative AudioHQ
- Creative Diagnostics
- Creative Wave Studio
- Creative PlayCenter
- Creative Recorder

To run Creative PlayCenter:

1. Click **Start -> Programs -> Creative -> Creative PlayCenter**
2. Click **Creative PlayCenter**.

To run other Creative Software applications:

1. Click **Start -> Programs -> Creative -> Sound Blaster Live!**
2. Click the application that you want to open.

# Creative Surround Mixer



To restore Surround Mixer to its original settings, click **Start -> Programs -> Creative -> Sound Blaster Live! -> Creative Restore Defaults.**

Creative Surround Mixer is the main application to use for the following tasks:

- Testing speakers
- Applying EAX-enabled audio effects
- Mixing sounds from various audio input sources
- Setting audio effects

Surround Mixer has two modes. Click the **Basic Mode** or **Advanced Mode** button to switch between the two modes:

In basic mode, the Mixer panel is displayed. You can:

- mix sounds from various audio input sources when playing or recording
- control volume, bass, treble, balance and fade

In advanced mode, the Surround Mixer and Mixer panels are displayed. In Surround Mixer, you can:

- select audio effects
- specify the speaker output
- perform a speaker test

For more information and usage details on Creative Surround Mixer, refer to its online Help.

# Creative AudioHQ

AudioHQ is Creative's audio software control center.

The AudioHQ interface has the standard look and feel of the Windows Control Panel. It contains several control applets that allow you to view, audition or set up the audio properties of one or more audio devices on your computer.

As in Control Panel, you can view AudioHQ's control applets in the main window as large icons, small icons, list items or detailed list items. You can also select all or invert the selection when you are in the Applet view. The number of items in the main window, however, varies with the control applet or device selected. The By Audio Device view shows only the control applets supported by the selected device. The Applet view shows only the audio devices that support the selected applet.

For more information and usage details on Creative AudioHQ, refer to its online Help.

## Creative Diagnostics

Use Creative Diagnostics to quickly test your audio card's Wave, MIDI or CD Audio playback capability, recording function and speaker output. For more information and usage details on Creative Diagnostics, refer to its online Help.

## SoundFont Control

SoundFont Control allows you to configure MIDI banks with SoundFont banks and instruments or DLS and Wave files, as well as set the caching algorithm and space.

For more information and usage details on SoundFont Control, refer to its online Help.

## Creative Keyboard

Creative Keyboard is a virtual keyboard that allows you to audition or play musical notes produced through MIDI devices.

## EAX Control

EAX Control allows you to configure the EMU10K1 chip's effects engine.

It allows you to specify to a low level the components that make up the audio elements that in turn make up an audio effect.

It promises to deliver sounds that are so life-like, you can almost see them! It is the computer industry's first system to recreate and deliver real-world, interactive audio experiences in games, music, and other audio applications. These audio effects take your computer beyond home-theater quality, immersing you in sound so vivid your imagination can almost "see it". The effects go beyond today's surround-sound and 3D positional audio and actually model an environment by taking into account room size, acoustic properties, reverb, echo and many other effects that create a real-world experience.

For more information and usage details on EAX Control, refer to its online Help.

## Creative Wave Studio

Creative WaveStudio allows you to perform the following sound editing functions easily:

- Play, edit, and record 8-bit (tape quality) and 16-bit (CD quality) wave data.
- Enhance wave data or create unique sounds with various special effects and editing operations such as reverse, echo, mute, pan, cut, copy, and paste
- Open and edit several audio files at the same time
- Open Raw (.RAW) and MP3 (.MP3) data files

For more information and usage details on Creative WaveStudio, refer to its online Help.

## Creative PlayCenter

Creative PlayCenter is a revolutionary audio CD and digital audio (such as MP3 or WMA) player. Besides managing your favorite digital audio files on your computer, it is also an integrated MP3/WMA encoder for ripping audio CD tracks into compressed digital audio files. It can encode tracks many times faster than normal play speed and up to 320 kbps (for MP3).

For more information and usage details on Creative PlayCenter, refer to its online Help.

**Note:** Audio files that are secured through Microsoft's Digital Rights Management (DRM) technology can only be played back on an MS DRM supported audio player such as Creative PlayCenter. For security against unauthorized duplication, Microsoft has advised the disabling of any digital or SPDIF output from the audio card.

## Creative Recorder

Recorder allows you to record sounds or music from various input sources like the microphone or Audio CD, and save them as Wave (.WAV) files. For more information and usage details on Creative Recorder, refer to its online Help.

# General Specifications

---

## Features

### PCI Bus Mastering

- ❑ Half-length PCI Specification Version 2.1 compliant
- ❑ Bus mastering reduces latency and speeds up system performance

### EMUI0KI

- ❑ Advanced hardware accelerated digital effects processing
- ❑ 32-bit digital processing while maintaining a 192 dB dynamic range
- ❑ Patented 8-point interpolation that achieves the highest quality of audio reproduction
- ❑ 64-voice hardware wavetable synthesizer
- ❑ Professional-quality digital mixing and equalization
- ❑ Up to 32 MB of sound RAM mapped to host memory

### Stereo Digitized Voice Channel

- ❑ True 16-bit Full Duplex operation
- ❑ 16-bit and 8-bit digitizing in stereo and mono modes
- ❑ Playback of 64 audio channels, each at an arbitrary sample rate
- ❑ ADC recording sampling rates: 8, 11.025, 16, 22.05, 24, 32, 44.1 and 48 kHz
- ❑ Dithering for 8-bit and 16-bit recording

## AC '97 Codec Mixer

- Mixes EMU10K1 audio sources and analog sources such as CD Audio, Line In, Microphone, Auxiliary and TAD
- Selectable input source or mixing of various audio sources for recording
- 16-bit Analog-to-Digital conversion of analog inputs at 48 kHz sample rate

## Volume Control



Some audio inputs may require additional optional equipment.

- Software playback control of Line In, Auxiliary, TAD, Microphone In, Wave/MP3, MIDI device, CD Digital (CD SPDIF)
- Software recording control of Line In, Auxiliary, TAD, Microphone In, Wave/MP3, MIDI device, CD Digital (CD SPDIF)
- Selectable input source or mixing of various audio sources for recording
- Adjustable master volume control
- Separate bass and treble control
- Front and rear balance control
- Muting and panning control for mixer sources

## Dolby Digital (AC-3) Decoding

- Decodes Dolby Digital (AC-3) to 5.1 channels or pass-through compressed Dolby Digital (AC-3) PCM SPDIF stream to external decoder
- Bass Redirection: Redirects bass to a subwoofer when the subwoofer is independent of the satellite speaker system.

## Creative Multi Speaker Surround (CMSS)

- Multi-speaker technology
- Professional-quality panning and mixing algorithm
- Independent multiple sounds can be moved and placed around a listener



# Connectivity

## Audio Inputs

- ❑ Line-level analog Line input via stereo connector on rear bracket
- ❑ Mono Microphone analog input via stereo connector on rear bracket
- ❑ CD\_IN line-level analog input via 4-pin Molex connector on card (on some cards)
- ❑ AUX\_IN line-level analog input via 4-pin Molex connector on card
- ❑ TAD line-level analog input via 4-pin Molex connector on card
- ❑ CD\_SPDIF digital input via 2-pin Molex connector on card, accepting sampling rates of 32, 44.1, and 48 kHz

## Audio Outputs

- ❑ ANALOG (center and subwoofer)/DIGITAL OUT (front and rear SPDIF digital outputs) or DIGITAL OUT only via 4-pole 3.5 mm miniplug on rear bracket..
- ❑ Three line-level analog outputs via stereo connectors on rear bracket (Front, Rear and Center/Subwoofer Line-Outs)
- ❑ Stereo headphone (32-ohm load) support on Front Line-Out

## Interfaces

- ❑ D-Sub MIDI interface for connection to external for connection to external MIDI devices. Doubles as Joystick port.
- ❑ PC\_SPK 1x2 pin header (on some cards)

# Troubleshooting

---

## Problems Installing Software

*The installation does not start automatically after the Sound Blaster Live! Installation CD is inserted.*

The AutoPlay feature in your Windows system may not be enabled.

*To start the installation program through the My Computer shortcut menu:*

1. On your Windows desktop, click the **My Computer** icon.
2. Right-click the CD-ROM drive icon, and then click **AutoPlay**.
3. Follow the instructions on the screen.

*To enable AutoPlay through Auto Insert Notification:*

1. Click **Start** -> **Settings** -> **Control Panel**.
2. Double-click the **System** icon. The **System Properties** dialog box appears.
3. Click the **Device Manager** tab and click your CD-ROM drive.
4. Click the **Properties** button.
5. Click the **Settings** tab and click **Auto Insert Notification**.
6. Click the **OK** button.

# Sound

*IRQ conflicts.*

To resolve IRQ conflicts, try the following.

- Place the audio card in another PCI slot.
- In your system BIOS, enable **Advanced Control** and **Power Interface** which allows IRQ sharing.

*There is unexpected, excessive environmental sound or effects when an audio file is being played.*

The last selected preset is an inappropriate environment for the current audio file.

*To switch to an appropriate environment:*

1. Open the Environmental Audio control utility.
2. Under **Environment**, click **No effects** or an appropriate environment.

*No sound from the headphones.*

*Verify the following:*

- The headphones are connected to the Line Out port.
- The master **Volume** of Surround Mixer is not set to mute.
- The **Digital Output Only** option is not selected.

*In a 4 or 5.1-speaker configuration, there is no sound from the rear speakers.*

*Check the following:*

- The rear speakers are connected to the audio card's Rear Out port.
- If you are playing sound from one of these sources:
  - CD Audio
  - Line In
  - TAD
  - Auxiliary (AUX)
  - Microphone

*To solve the problem:*

1. In Surround Mixer, make sure the source being played is unmuted, that is, enabled.
2. Select the same source as the record source.

For example, if you have a portable CD player plugged into the Line In connector, unmute Line In in Surround Mixer, and select Line In as your record source.

- If you change environments, go to Surround Mixer and unmute your active sources.

*No sound from the speakers.*

*Check the following:*

- Speakers are correctly connected to your audio card's output.
- You have unmuted the correct source in Surround Mixer.

If both these conditions have been met and you still do not have sound, click the red plus sign above the **VOL** button. If the **Digital Output Only** check box is selected, you are in Digital Output Only mode and must connect to digital speakers to hear the sound from your audio card.

*No audio output when playing digital files such as .WAV, MIDI files or AVI clips.*

*Possible causes:*

- Speaker volume (if any) is not set properly.
- External amplifier or speakers are connected to the wrong port.
- Hardware conflict.
- Speakers selection in Surround Mixer is incorrectly selected.
- Original Sound in either the **Master** or **Source** tabs of EAX Control Panel is set at or near 0%.

*Check the following:*

- Speakers' volume control, if any, is set at mid-range. Use Creative Mixer to adjust the volume, if necessary.
- Powered speakers or external amplifier are connected to the card's Line Out or Rear Out port.
- No hardware conflict between the card and a peripheral device. See "I/O Conflicts" on page B-7.
- Speakers selection in Surround Mixer corresponds to your speaker or headphone configuration.
- Original Sound in either/both the **Master** and **Source** tabs of EAX Control Panel is set to 100%.



If digital CD audio is enabled, CD volume is controlled by the Wave/MP3 slider in Surround Mixer.

*No audio output when playing CD-Audio.*

*To solve this problem, do one or more of the following:*

- Make sure the Analog Audio connector on the CD-ROM drive and the AUX/CD In connector on the audio card are connected.
- Enable digital CD Playback. See "Enabling CDDA" on page 1-6.

# Problems with File Transfers on Some VIA Chipset Motherboards

After you install the Sound Blaster Live! card on a VIA chipset motherboard, you may have the slight chance of seeing one of the following:

*When transferring large amounts of data, the computer stops responding ('hangs') or restarts itself, OR Files transferred from another drive are incomplete or corrupted.*

These problems appear in a small number of computers, which contain the VIA VT82C686B controller chipset on their motherboards.

To verify if your motherboard has the VT82C686B chipset:

- Refer to your computer or motherboard manual, or
- In Windows:
  - i. Click **Start -> Settings -> Control Panel**.
  - ii. Double-click the **System** icon.
  - iii. Click the **Device Manager** or **Hardware** tab.
  - iv. Click the **Systems devices** icon.
  - v. In the list that appears, see if the items highlighted in Figure B-1 appear.
  - vi. If the items appear, remove your computer cover and locate the VIA chipset on your motherboard. (Take note of the safety precautions on page 1-3.)  
The VT82C686B chipset has its model number inscribed on the chip.

If you have the VT82C686B chipset, Creative recommends that you first contact your computer vendor or motherboard manufacturer for the latest solution.

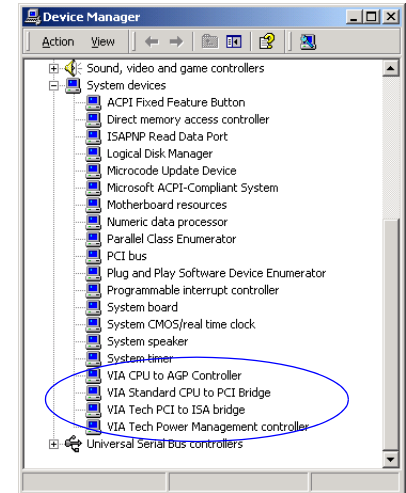

Figure B-1: Device Manager tab.

## Insufficient SoundFont Cache

Some users have solved the above problems by doing one or both of the following:

- ❑ downloading the latest VIA 4in1 drivers from <http://www.viatech.com>\*,
- ❑ obtaining the most current BIOS for your motherboard from the manufacturer's web site\*.

\*Content in these web sites is controlled by other companies. Creative bears no responsibility for information or downloads obtained from them. This information is provided only as a convenience to you.

*There is insufficient memory to load SoundFonts.*

This may occur when a SoundFont-compatible MIDI file is loaded or played.

*Cause:* There is insufficient memory allocated to SoundFonts.

*To allocate more SoundFont cache:*

- ▶ On the **Options** tab of SoundFont Control, drag the **SoundFont Cache** slider to the right. The amount of SoundFont cache you can allocate depends on the system RAM available.

*If there is still insufficient system RAM available:*

- ▶ On the **Configure Banks** tab of SoundFont Control, click a smaller SoundFont bank from the **Select Bank** box. If not, you may need to increase your system's RAM.

## Joystick

*The joystick port is not working.*

The audio card's joystick port conflicts with the system's joystick port.

*To solve this problem:*

- ▶ Disable the audio card's joystick port and use the system port instead.

*The joystick is not working properly in some programs.*

The program may use the system processor timing to calculate the joystick position. When the processor is fast, the program may determine the position of the joystick incorrectly, assuming that the position is out of range.

*To solve this problem:*

- ▶ Increase your system's 8 bit I/O recovery time of the BIOS setting, usually under the Chipset Feature Settings section. Or, if available, you may adjust the AT Bus speed to a slower clock. If the problem persists, try a different joystick.

## I/O Conflicts

Conflicts between your audio card and another peripheral device may occur if your card and the other device are set to use the same I/O address.

To resolve I/O conflicts, change the resource settings of your audio card or the conflicting peripheral device in your system using Device Manager in Windows.

If you still do not know which card is causing the conflict, remove all cards except the audio card and other essential cards (for example, disk controller and graphics cards). Add each card back until Device Manager indicates that a conflict has occurred.

*To resolve hardware conflicts in Windows:*

1. Click **Start** -> **Settings** -> **Control Panel**.
2. Double-click the **System** icon. The **System Properties** dialog box appears.
3. Click the **Device Manager** tab.
4. Click **Sound, video and game controllers**, and then click the conflicting audio card driver (indicated by an exclamation mark).
5. Click the **Properties** button.
6. Click the **Resources** tab.
7. Make sure that the **Use automatic settings** check box is selected, and click the **OK** button.
8. Restart your computer to allow Windows to reassign resources to your audio card and/or the conflicting device.



## Problems in Windows XP

At the time of this product's release, Microsoft strongly encouraged companies to submit their hardware solutions for certification. If a hardware device driver is not submitted, or does not qualify, for Microsoft certification, a warning message similar to the one shown here, appears.

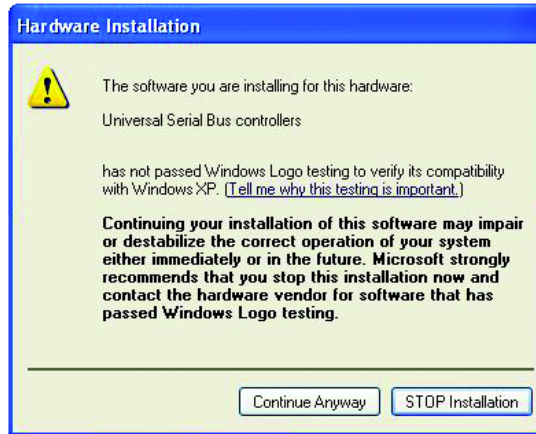

You may see the message when installing this driver. If you do, you may choose to click the **Continue Anyway** button. Creative has tested this driver on Windows XP, and it does not impair or destabilize your computer.