

DIGITAL PIANO

L1

Service Manual

Manufacturing Date: April 2002

KAWAI Kawai Musical Instruments
Manufacturing Co., Ltd.

SPECIFICATIONS







Action Hammer	Advanced Hammer Action II
Max Polyphony	32 (Stereo 16)
Tone Color	8 Tones Classic Grand Harpsichord Modern Piano Vibraphone E.Piano Strings Church Organ Choir
Display	None
Effect	Reverb (Room / Stage / Hall) Chorus
Function	Dual Transpose Tune Touch Curve Select (Light / Normal / Heavy / Off)
Recorder	1 Song, 1 Track, approximately 1,800 Notes
Demo	8 Songs
Concert Magic	40 Songs
Metronome	1/4, 2/4, 3/4, 4/4, 6/8
Pedal	Damper, Soft (when used with optional F-2r pedal unit)
Jack	MIDI IN, OUT LINE IN Headphone x 2
Speaker	12cm x 2
Output Power	7W x 2
AC Adapter	PS-125
Power Consumption	for 120V area 30W for 230V area 22W
Weight	30 kg
Dimensions	136.0 x 27.2 x 75.6 cm
Accessories	Music Rack, AC Adaptor, F-1r Foot Pedal, Cloth Dust Cover

CONTENTS

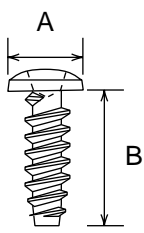
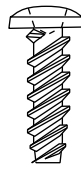
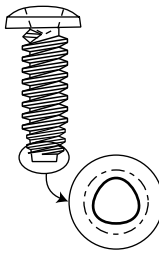
HARDWARE LIST	1
CASE (1) ASSEMBLY	2
CASE (2) ASSEMBLY	3
KEYBOARD UNIT (RF88 type)	4
KEY SWITCH ADJUSTMENT (RF88 type)	5
CABLE WIRING DIAGRAM	6
PARTS LIST	7
BLOCK DIAGRAM	10
P.W.B. KEP-062 ASSEMBLY (TOP)	11
P.W.B. KEP-062 ASSEMBLY (BACK)	12
P.W.B. KEP-062 CIRCUIT (1 / 3)	13
P.W.B. KEP-062 CIRCUIT (2 / 3)	14
P.W.B. KEP-062 CIRCUIT (3 / 3)	15
P.W.B. KEP-096 / 097 / 098 ASSEMBLY	16
P.W.B. KEP-096 / 097 / 098 CIRCUIT	17
P.W.B. KEP-064 / 065 / 066 ASSEMBLY	18
P.W.B. KEP-064 / 065 CIRCUIT (1 / 2)	19
P.W.B. KEP-064 / 065 CIRCUIT (2 / 2)	20
P.W.B. KEP-066 CIRCUIT	21
P.W.B. KKB-015 (Key Switch) CIRCUIT	22

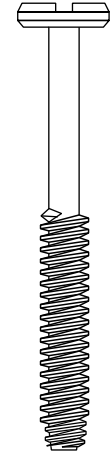
HARDWARE LIST

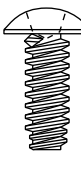
Type	Size (AxB)	Remarks
+ Truss Head Tapping #1	4x16	
+ Binding Head P-Tite	4x6	
+ Binding Head P-Tite	3x8	
+ Pan Head Machine Screw with Washer	M5x20	Spring + Plain
+ Truss Head Machine Screw	M4x20	
+ Binding Head S-Tite	3x6(8)	
+ Binding Head P-Tite	3x6	
+ Truss Head Tapping #1	4x12	
+ Bind Head Tapping #1	3x16	Chromating (Black)
+ Truss Head Tapping #1	4x10	
+ Truss Head Tapping #1	4x18	
+ Truss Head Machine Screw	M4x20	Chromating (Black)
+ Truss Head Tapping #1	4x25	Chromating (Black)
+ Binding Head B-Tite	3x8	
+ Binding Head B-Tite	3x12	
+ Binding Head P-Tite	3x10	Chromating (Black)
Volume Nut	M12	Chromating (Black or Yellow)
+ Truss Head Tapping #1	4x14	Chromating (Black)
+ Flat Head Tapping #1	4x25	Chromating (Black)
JCB Type B ± Head	M6x70	
+ Bind Head Tapping #1	3x10	Chromating (Black)
+ Truss Head Machine Screw	M6x25	Chromating (Black)

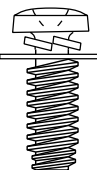
+Binding Head Tapping			+Binding Head Tapping #1	JCB Type B ± Head
B-Tite	P-Tite	S-Tite		
				
+Truss Head Tapping #1	+Truss Head Machine	+Flat Head Tapping #1	+Pan Head Machine Screw with Washer	
				

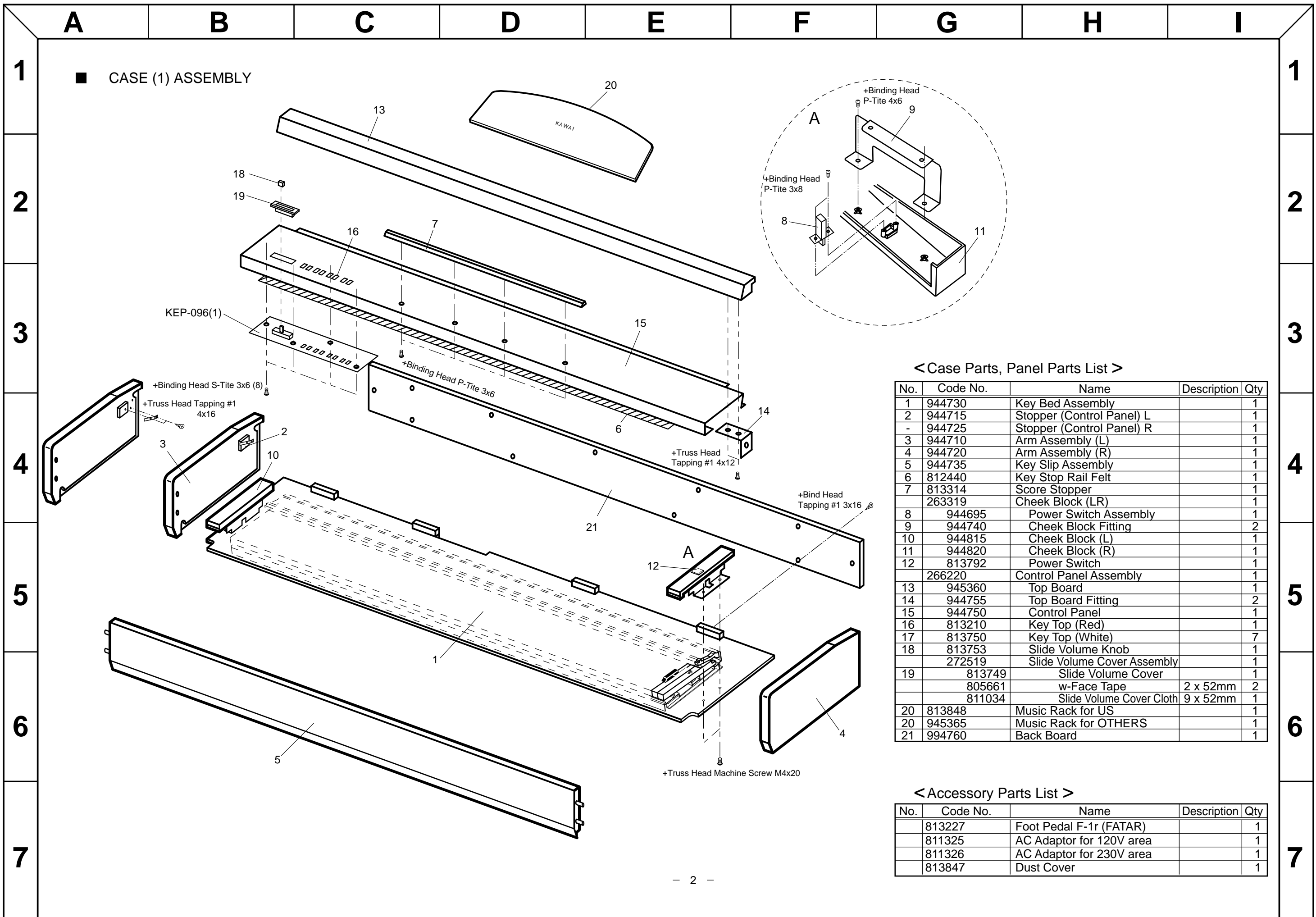

■ CASE (1) ASSEMBLY

< Case Parts, Panel Parts List >

No.	Code No.	Name	Description	Qty
1	944730	Key Bed Assembly		1
2	944715	Stopper (Control Panel) L		1
-	944725	Stopper (Control Panel) R		1
3	944710	Arm Assembly (L)		1
4	944720	Arm Assembly (R)		1
5	944735	Key Slip Assembly		1
6	812440	Key Stop Rail Felt		1
7	813314	Score Stopper		1
	263319	Cheek Block (LR)		1
8	944695	Power Switch Assembly		1
9	944740	Cheek Block Fitting		2
10	944815	Cheek Block (L)		1
11	944820	Cheek Block (R)		1
12	813792	Power Switch		1
	266220	Control Panel Assembly		1
13	945360	Top Board		1
14	944755	Top Board Fitting		2
15	944750	Control Panel		1
16	813210	Key Top (Red)		1
17	813750	Key Top (White)		7
18	813753	Slide Volume Knob		1
	272519	Slide Volume Cover Assembly		1
19	813749	Slide Volume Cover		1
	805661	w-Face Tape	2 x 52mm	2
	811034	Slide Volume Cover Cloth	9 x 52mm	1
20	813848	Music Rack for US		1
20	945365	Music Rack for OTHERS		1
21	994760	Back Board		1

< Accessory Parts List >

No.	Code No.	Name	Description	Qty
	813227	Foot Pedal F-1r (FATAR)		1
	811325	AC Adaptor for 120V area		1
	811326	AC Adaptor for 230V area		1
	813847	Dust Cover		1

A B C D E F G H I

1
2
3
4
5
6
7

1
2
3
4
5
6
7

■ CASE (2) ASSEMBLY

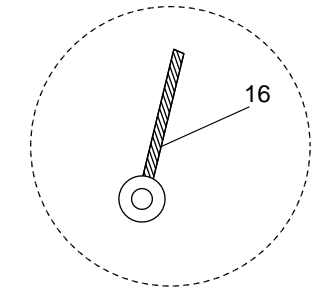
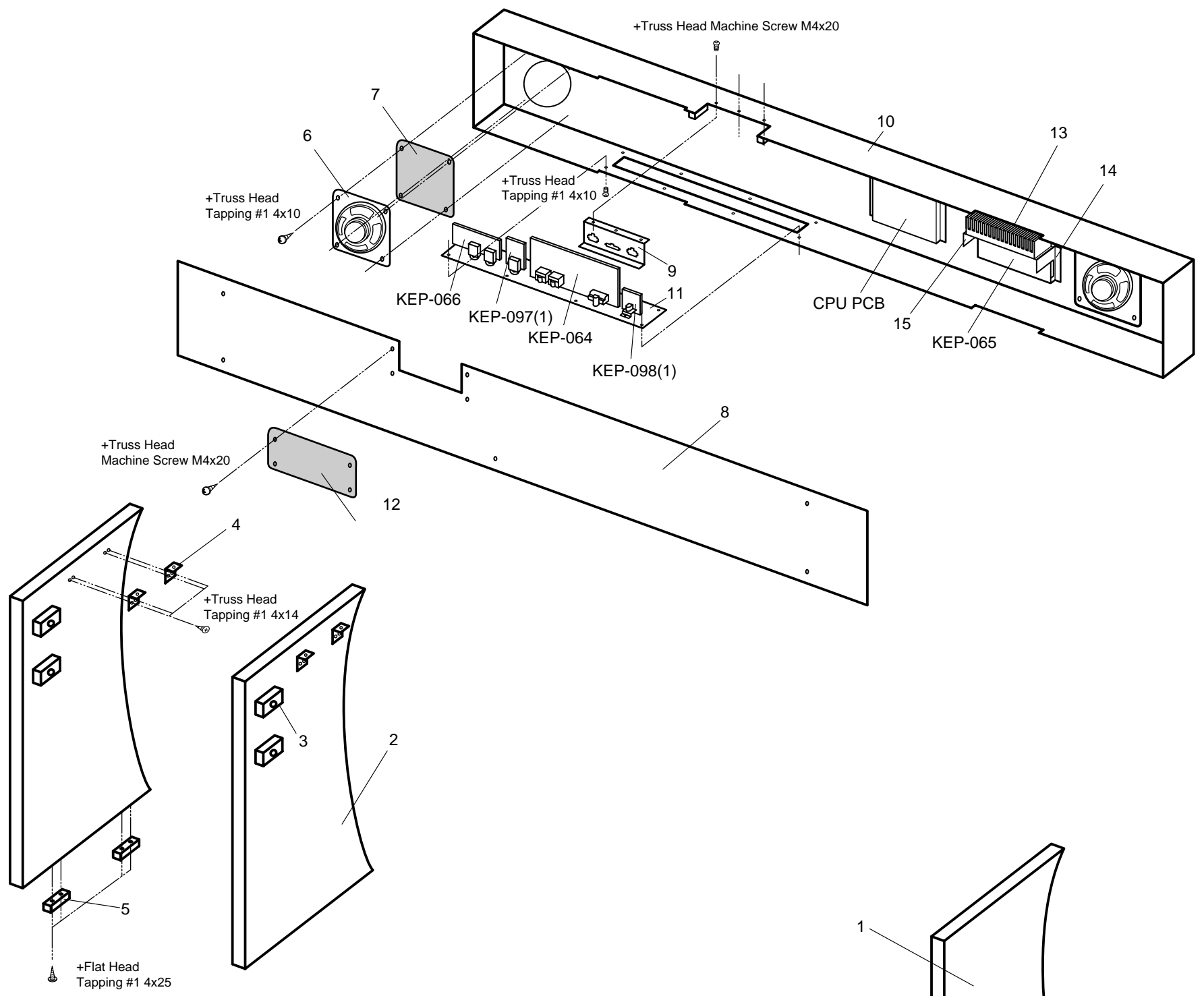

< Speaker Box Parts, Side Board Parts List >

No.	Code No.	Name	Description	Qty
1	944780	Side Board (L)		1
2	944785	Side Board (R)		1
3	944790	Block		4
4	944795	Case Fitting		4
5	787883	Flat Leg		4
	813844	Accessory Screws		1
	269704	Speaker Box Assembly		1
6	812952	Speaker		2
7	934155	Punching Metal		2
8	944770	Speaker Box Back Board		1
9	944775	Connector Fitting		1
10	944765	Speaker Box		1
11	944705	Jack Panel		1
12		Connector Cover		1
13	812953	Heatsink		1
14	933080	Heatsink Fitting (L)		1
15	933075	Heatsink Fitting (R)		1
16	721220	Cable Binder		1
	811233	Cable Band		1
	813756	Jack Sticker		1

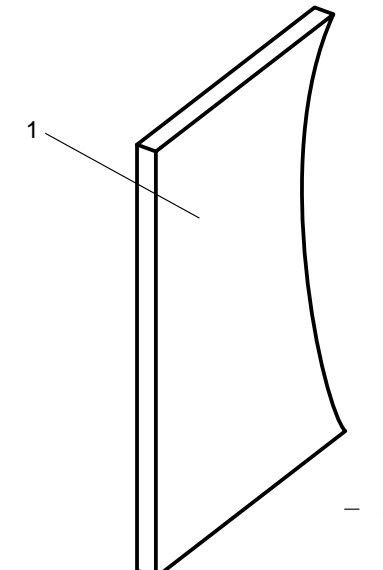

A B C D E F G H I

**1
2
3
4
5
6
7**

**1
2
3
4
5
6
7**

■ Keyboard Unit

Type : RF-88

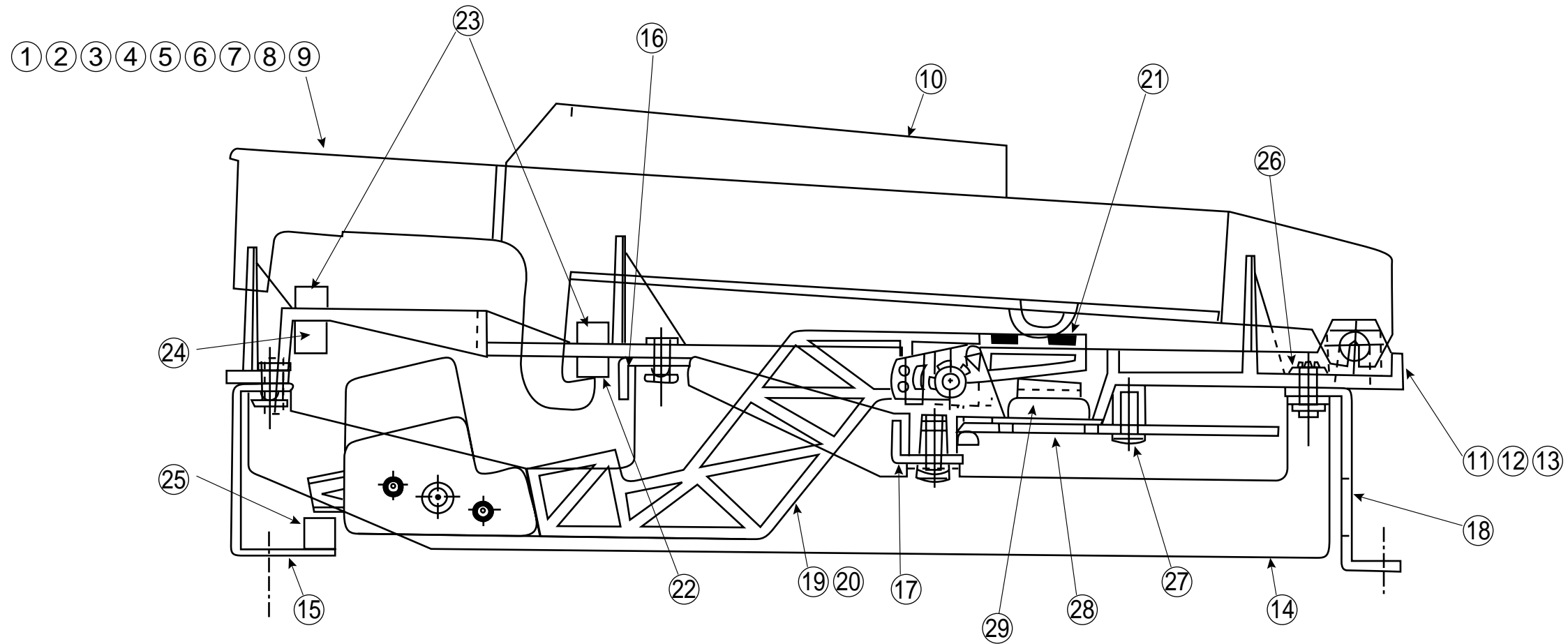

List

No.	Code No.	Name	Descripton	Qty	No.	Code No.	Name	Descripton	Qty	No.	Code No.	Name	Descripton	Qty
	813495	RF 88 Keyboard Unit			10	813164	Black Key		36	20	941525A	Hammer Assembly (Black Key)		36
1	813155	White Key (C)		7	11	813165	Chassis (F-E)		6	21	813170	Slip Tape		88
2	813156	White Key (D)		7	12	813166	Chassis (A-E)		1	22	813171	Key Stop Cushion		1
3	813157	White Key (E)		7	13	813167	Chassis (F-C)		1	23	813172	Key Stop Felt		2
4	813158	White Key (F)		7	14	941495	Rib		8	24	813173	Hammer Stopper Cushion		1
5	813159	White Key (G)		7	15	941500	Angle Steel (Front)		1	25	809969	Front Felt		1
6	813160	White Key (A)		7	16	941505	Angle Steel (Stopper)		1	26	-	Chassis Fix Screw (1)	3 x 8 (B Tite)	94
7	813161	White Key (B)		8	17	941510	Angle Steel (Switch)		1	27	-	Chassis Fix Screw (2)	3 x 8 (P Tite)	46
8	813162	White Key (AA)		1	18	941516	Angle Steel (Back)		1	28	237347	Switch PCB Assembly		1
9	813163	White Key (CC)		1	19	941520A	Hammer Assembly (White Key)		52	29	813175	Rubber Switch		8

KEYBOARD DISASSEMBLING PROCEDURE

First, remove the keyboard fixing screws (10 pcs.) at the bottom of the piano and slide the keyboard unit backward.

<How to take a key off>

1. Spread the key at fulcrum point and lift it up. (We recommend to use O-ring pliers. If not available, use a flat blade (tapered) screwdriver.)
2. Pull the key off. (Pay attention to the stopper.)

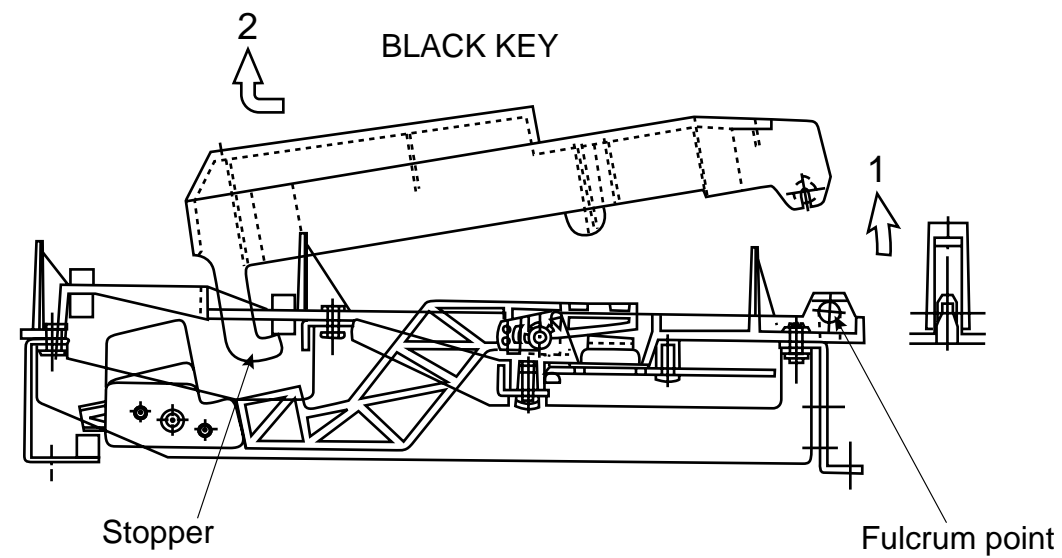
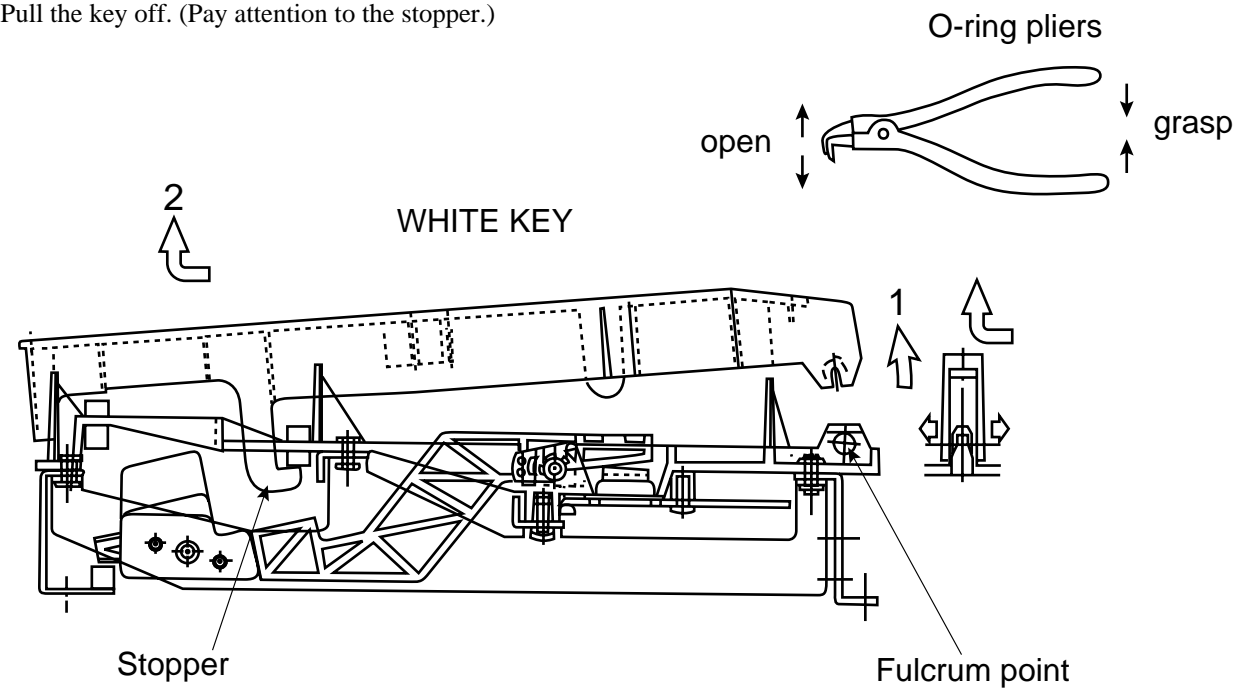

<How to take a hammer off>

1. Lift the hammer at the fulcrum point.
2. Pull the hammer off.

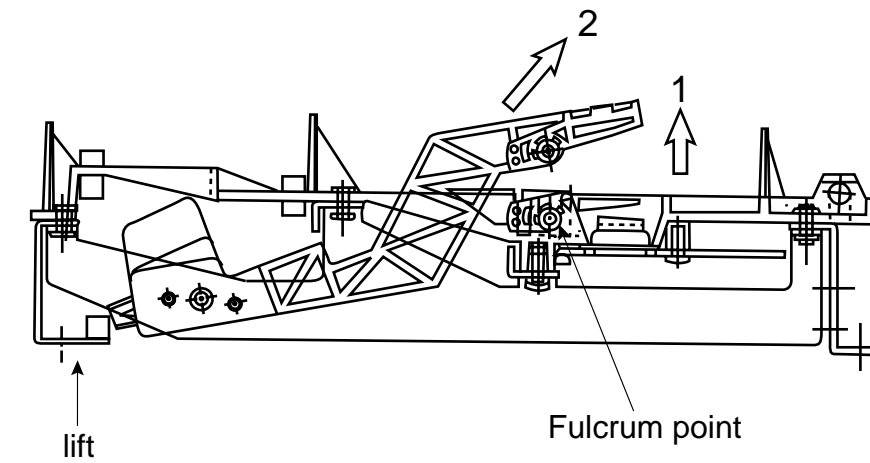

* When taking a hammer for **white key** off, lift the keyboard chassis up at front.

* To remove a black key, the white keys on either side must be removed first.

A **B** **C** **D** **E** **F** **G** **H** **I**

1
2
3
4
5
6
7

1
2
3
4
5
6
7

■ CABLE WIRING DIAGRAM

● :Viny Binber
A :Cable Tie
B :Tape

KEYBOARD SIDE

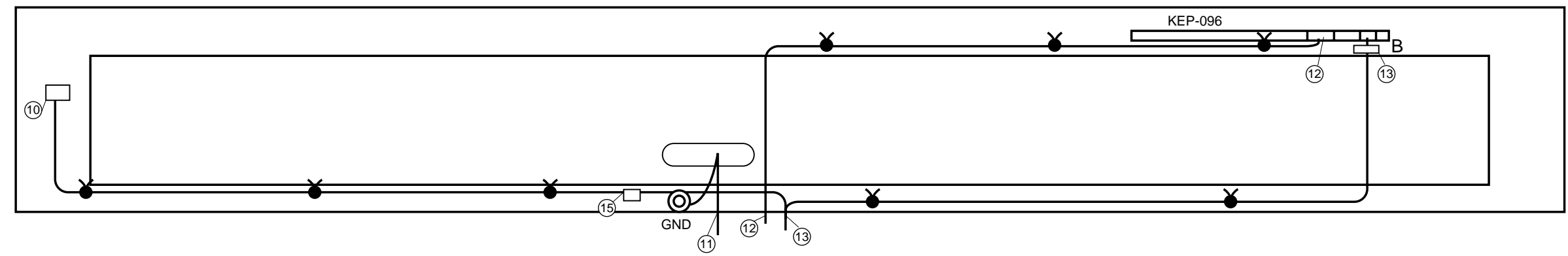

SPEAKER BOX SIDE

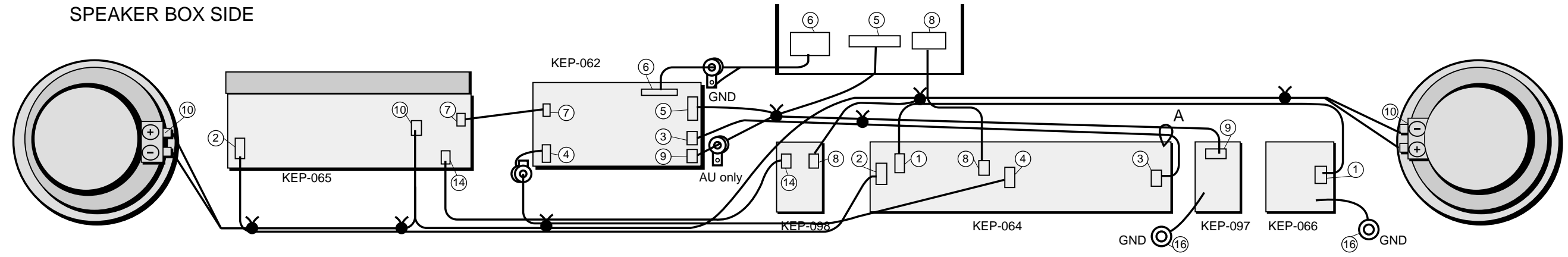

No.	Termination 1	Termination 2	Code No.	Name	Description	Qty	No.	Termination 1	Termination 2	Code No.	Name	Description	Qty
1	KEP-066 CN201	KEP-064 CN2	942190	Headphone Cable		1	10	KEP-065 CN105	Speaker	944670	Speaker cable		1
2	KEP-064 CN4	KEP-065 CN101	942295	Jack Cable		1	11	Keyboard	Connector Panel	944675	Keyboard Cable (upper)		1
3	KEP-062 CN2	KEP-064 CN6	941755	MIDI Cable		1	12	KEP-096 CN1	Connector Panel	944680	Panel Cable (upper)		1
4	KEP-062 CN8	KEP-064 CN1	945345	CPU Out Cable		1	13	Connector Panel	KEP-096 CN2	944685	Volume Cable (upper)	1 to 2	1
5	KEP-062 CN1	Connector Panel	944650	Panel Cable (under)		1	14	KEP-098 CN5	KEP-065 CN106	944690	Power Cable		1
6	KEP-062 CN6	Connector Panel	945350	Keyboard Cable (under)		1	15	Connector	Power SW	944695	Power SW Cable		1
7	KEP-062 CN7	KEP-065 CN104	944660	CPU Power Cable		1	16	KEP-066	Chassis	812267	Jack Grand Cable		1
8	KEP-064 CN3	Connector Panel	944665	Volume Cable (under)	2 to 1	1	17	KEP-097	Chassis	812267	Jack Grand Cable		1
	KEP-098 CN4												
9	KEP-097 CN3	KEP-062 CN3		Pedal Cable (except AU)		1							
				Pedal Cable (AU only)	with Ferrite core	1							

Part List

Printed Circuit Board

Name	Code No.	Description	Ref. Page
KEP-062 (20)	237488	CPU	10-15
KEP-096 (1)-098 (1) x2	237478	Panel/Foot Switch/DC IN	16-17
KEP-096 (1) x2	237478A	Panel	16-17
KEP-097 (1) x2	237478B	Foot SW	16-17
KEP-098 (1) x2	237478C	DC IN	16-17
KEP-064 (12)-068 (12) for 120V area	237477	Jack/Amp	18-21
KEP-064 (14)-068 (14) for 230V area	237489	Jack/Amp	18-21
KEP-064 (15)-068 (15) for 120V area (Made in Indonesia)	237532	Jack/Amp	18-21
KEP-064 (16)-068 (16) for 230V area (Made in Indonesia)	237533	Jack/Amp	18-21
KEP-064 (12) for 120V area	237477A	Jack/Amp	18-20
KEP-064 (14) for 230V area	237489A	Jack/Amp	18-20
KEP-064 (15) for 120V area (Made in Indonesia)	237532A	Jack/Amp	18-20
KEP-064 (16) for 230V area (Made in Indonesia)	237533A	Jack/Amp	18-20
KEP-065 (12) for 120V area	237477B	Amp	18-20
KEP-065 (14) for 230V area	237489B	Amp	18-20
KEP-065 (15) for 120V area (Made in Indonesia)	237532B	Amp	18-20
KEP-065 (16) for 230V area (Made in Indonesia)	237533B	Amp	18-20
KEP-066 (12) for 120V area	237477C	Jack	18,21
KEP-066 (14) for 230V area	237489C	Jack	18,21
KEP-066 (15) for 120V area (Made in Indonesia)	237532C	Jack	18,21
KEP-066 (16) for 230V area (Made in Indonesia)	237533C	Jack	18,21
KEP-067 (12)		(Not in use)	
KEP-067 (14)		(Not in use)	
KEP-067 (15)		(Not in use)	
KEP-067 (16)		(Not in use)	
KEP-068 (12)		(Not in use)	
KEP-068 (14)		(Not in use)	
KEP-068 (15)		(Not in use)	
KEP-068 (16)		(Not in use)	

Printed Circuit Board

Code No.	Name	Description	Ref. Page	Qty
237488	KEP-062(20)		10 - 12	1
810368	IC, Voltage Regulator	NJM78L05UA	11	1
811645	IC, Reset	PST575CMT	11	1
811653	IC, OP-AMP	M5218AFP	11	1
812217	IC, HCMOS	TC74HCT7007AF	11	1
812427	IC, SRAM	GM76C8128CLLFW-70	11	1
812954	IC, LG Tone Generator	K021-FP	11	1
813047	IC, Voltage Regulator	u PC2933T	11	1
812979	IC, MPU/Flash ROM	MB91F109PF-G	11	1
804056	IC, HCMOS	HD74HC245FP	12	1
811483	IC, DAC	u PD63200GS	12	1
813255	IC, Mask Rom	KP275B-MCFW	12	1
808945	Chip Bead	BK2125HS601	11	10
809834	Diode	HSK120	11	1
810920	Transistor	DTC143EK	11	4
811646	Chip Inductor	LK2125R56K	11	1
812722	Crystal Resonator	SMD-49	11	1
812958	Crystal Oscirator	DSO751SV	11	1
237478	KEP-096(1)-098(1) x2	Panel, Foot Switch, DC IN	16	1
237478A	KEP-096(1) x2	Panel	16	1
804978	Slide Volume	RS30112AC00QA	16	1
800625	Diode	1SS133	16	8
808345	Tact Switch	KSH0612AT	16	8
813111	LED	3105VRT	16	8
237478B	KEP-097(1) x2	Foot Switch	16	1
802576	Phone Jack	YKB21-5006	16	1
812267	Headphone Ground Cable	KPBB-0111	16	1
811020	Surge Absorbers	ERZ-VA5D220	16	2
810851	Transistor	DTC143ESA	16	2
237478C	KEP-098(1) x2	DC IN	16	1
811658	Diode	SB2004A	16	1

Code No.	Name	Description	Ref.Page	Qty
237477	KEP-064(12)-068(12) for 120V area	Jack/Amp	18	1
237489	KEP-064(14)-068(14) for 230V area	Jack/Amp	18	1
237532	KEP-064(15)-068(15) for 120V area	Jack/Amp (Made in Indonesia)	18	1
237533	KEP-064(16)-068(16) for 230V area	Jack/Amp (Made in Indonesia)	18	1
237477A	KEP-064(12) for 120V area	Jack/Amp	18	1
237489A	KEP-064(14) for 230V area	Jack/Amp	18	1
237532A	KEP-064(15) for 120V area	Jack/Amp (Made in Indonesia)	18	1
237533A	KEP-064(16) for 230V area	Jack/Amp (Made in Indonesia)	18	1
806719	IC, Photocoupler	PC900V	18	1
800676	IC, OP AMP	M5218AP	18	1
812222	IC, OP AMP	LA6517	18	1
811018	IC, Reset	PST600C	18	1
808473	MIDI Jack	YKF51-5053	18	1
810851	Transistor	DTC143ESA	18	3
808973	Transistor	DTA114ESA	18	1
812527	Transistor	2SC5395	18	1
807082	Zenor Diode	HZS6C3	18	1
800625	Diode	1SS133	18	3
808979	Pin Jack	YKC21-3045	18	1
237477B	KEP-065(12) for 120V area	Amp	18	1
237489B	KEP-065(14) for 230V area	Amp	18	1
237532B	KEP-065(15) for 120V area	Amp (Made in Indonesia)	18	1
237533B	KEP-065(16) for 230V area	Amp (Made in Indonesia)	18	1
807032	IC, Voltage Regulator	PQ05RD11	18	1
812950	IC, Power AMP	TA8221AH	18	1
800676	IC, OP AMP	M5218AP	18	1
811018	IC, Reset	PST600C	18	1
812961	IC Protector	ICP-N10	18	1
812527	Transistor	2SC5395	18	9
810851	Transistor	DTC143ESA	18	1
807082	Zenor Diode	HZS6C3	18	1
805989	Zener Diode	HZS4ALL	18	1
237477C	KEP-066(12) for 120V area	Jack	18	1
237489C	KEP-066(14) for 230V area	Jack	18	1
237532C	KEP-066(15) for 120V area	Jack (Made in Indonesia)	18	1
237533C	KEP-066(16) for 230V area	Jack (Made in Indonesia)	18	1
812267	Headphone Ground Cable	KPBB-0111	18	1
802576	Phone Jack	YKB21-5006	18	2

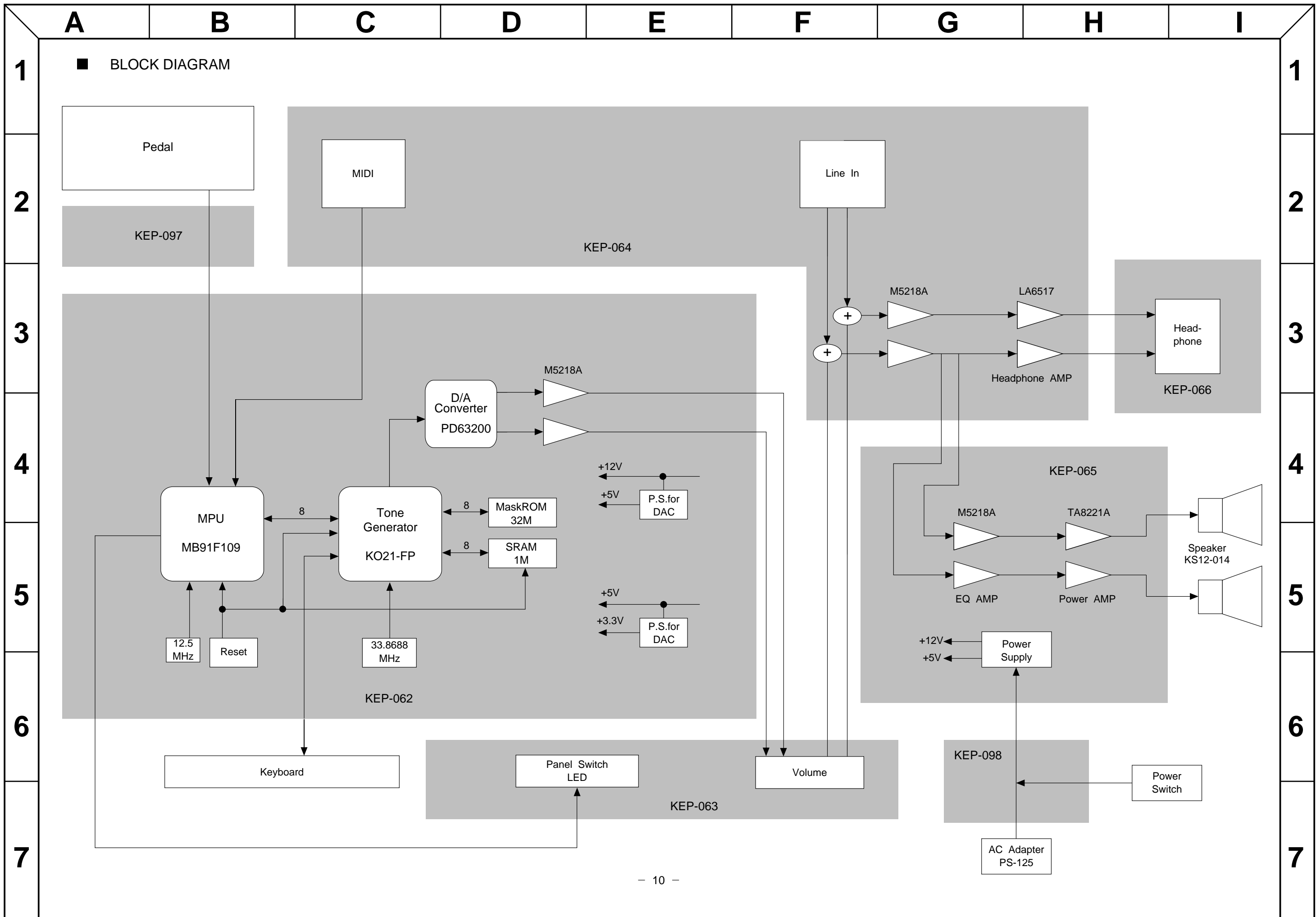

A B C D E F G H I

1
2
3
4
5
6
7

P.W.B. KEP-062 ASSEMBLY (TOP)

1
2
3
4
5
6
7

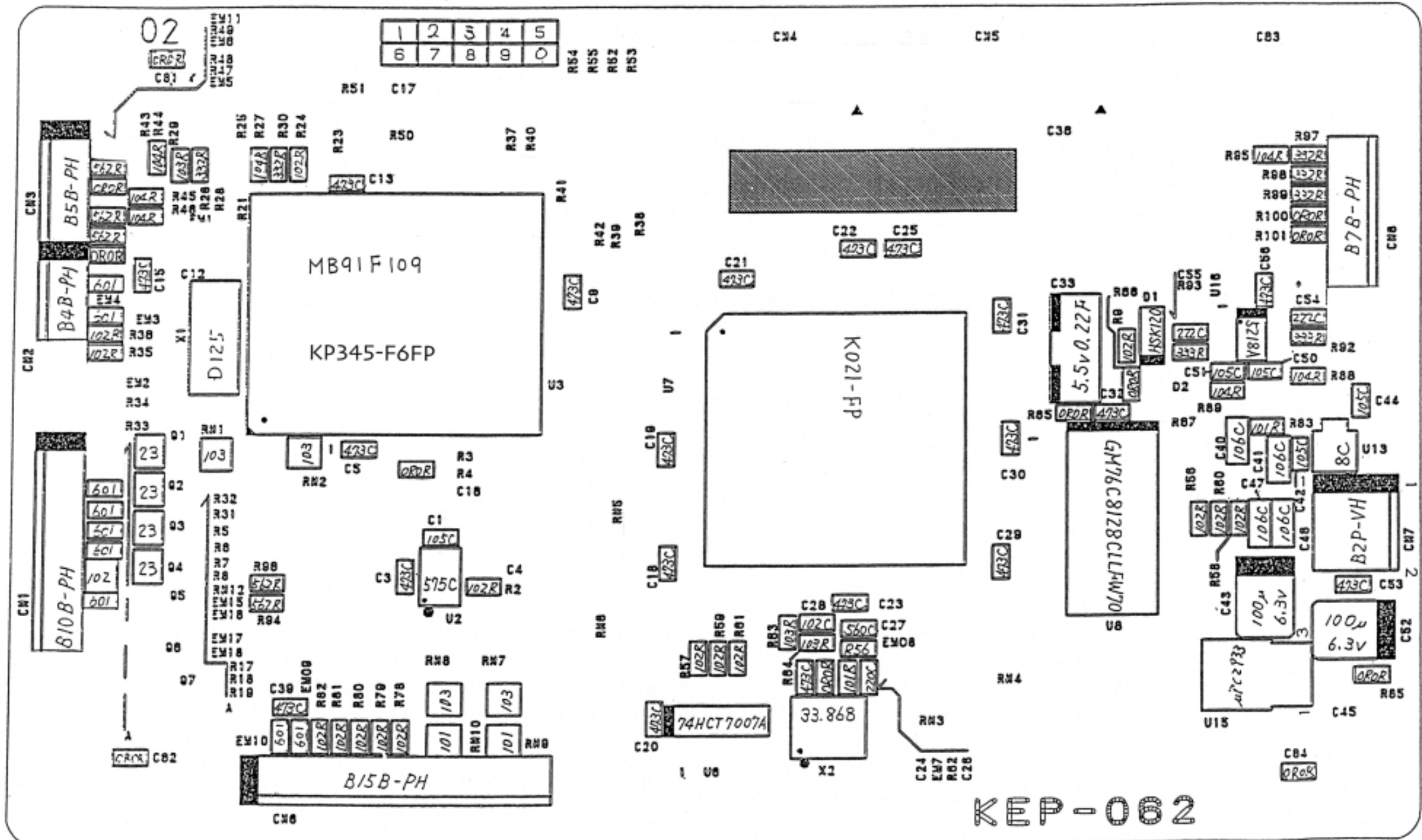

A B C D E F G H I

1
2
3
4
5
6
7

1
2
3
4
5
6
7

P.W.B. KEP-062 ASSEMBLY (BACK)

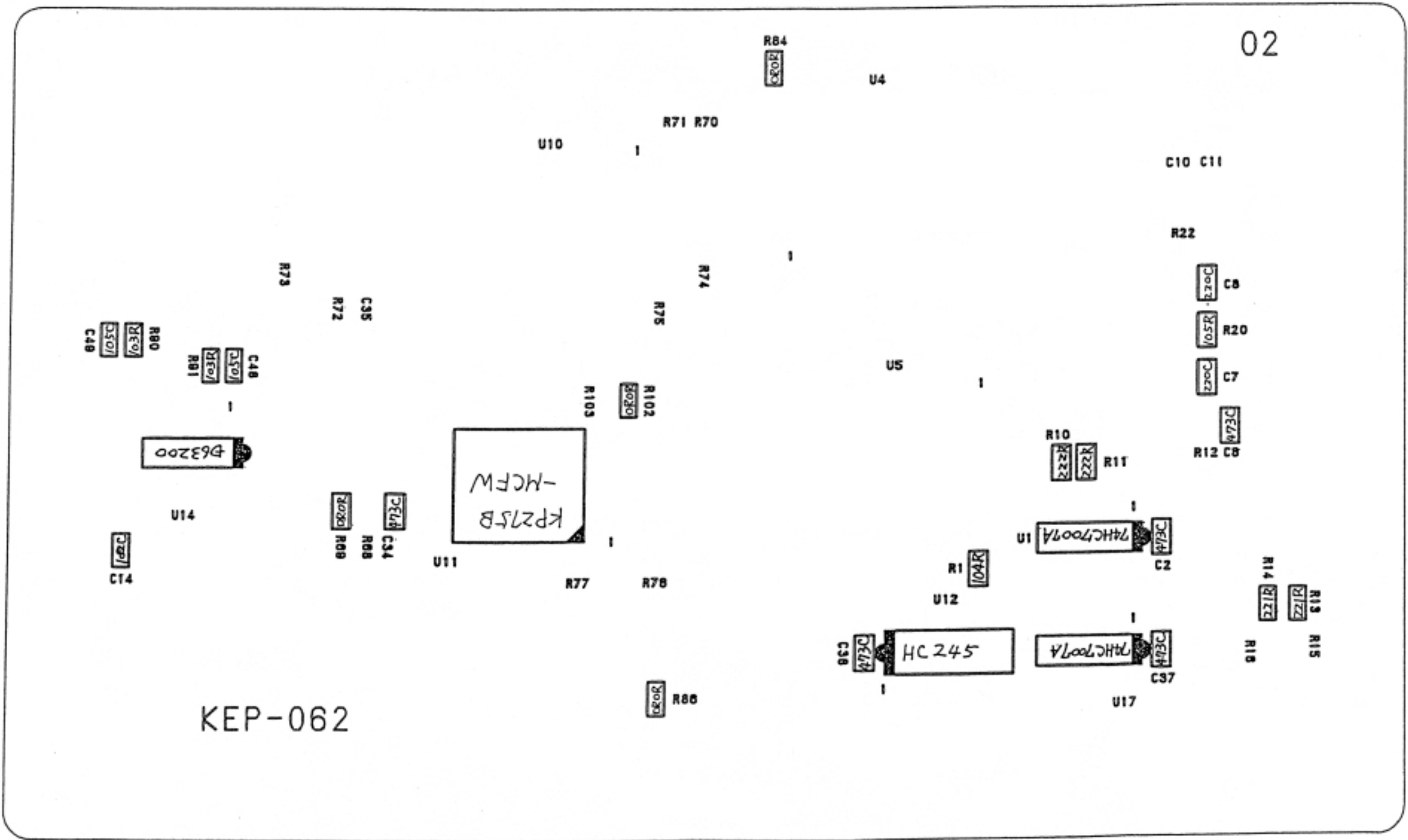

KEP-062 CIRCUIT (1/3) < CPU >

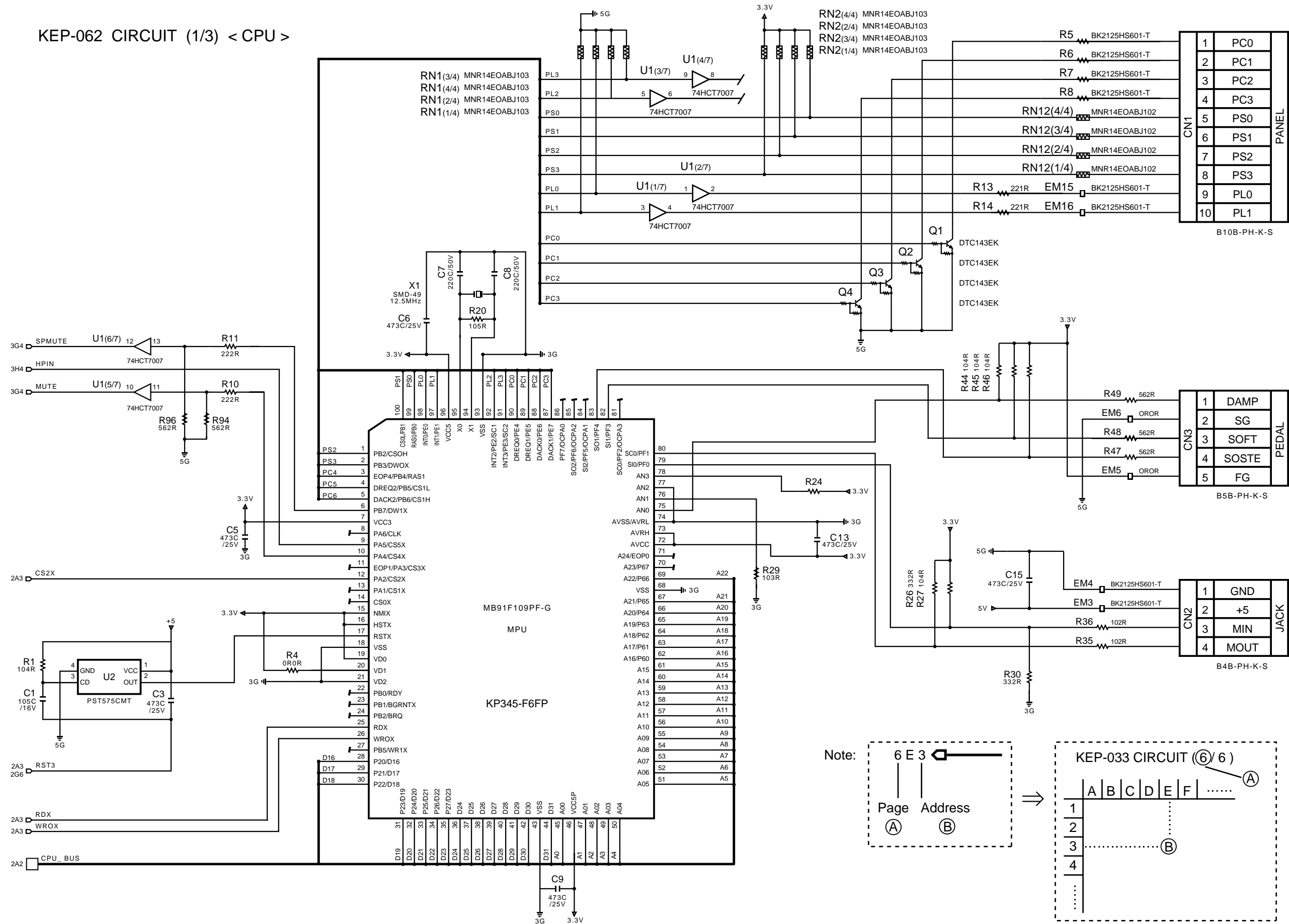

KEP-062 CIRCUIT (2/3) < CPU >

*Use A or B depends on the type of MASK ROM.

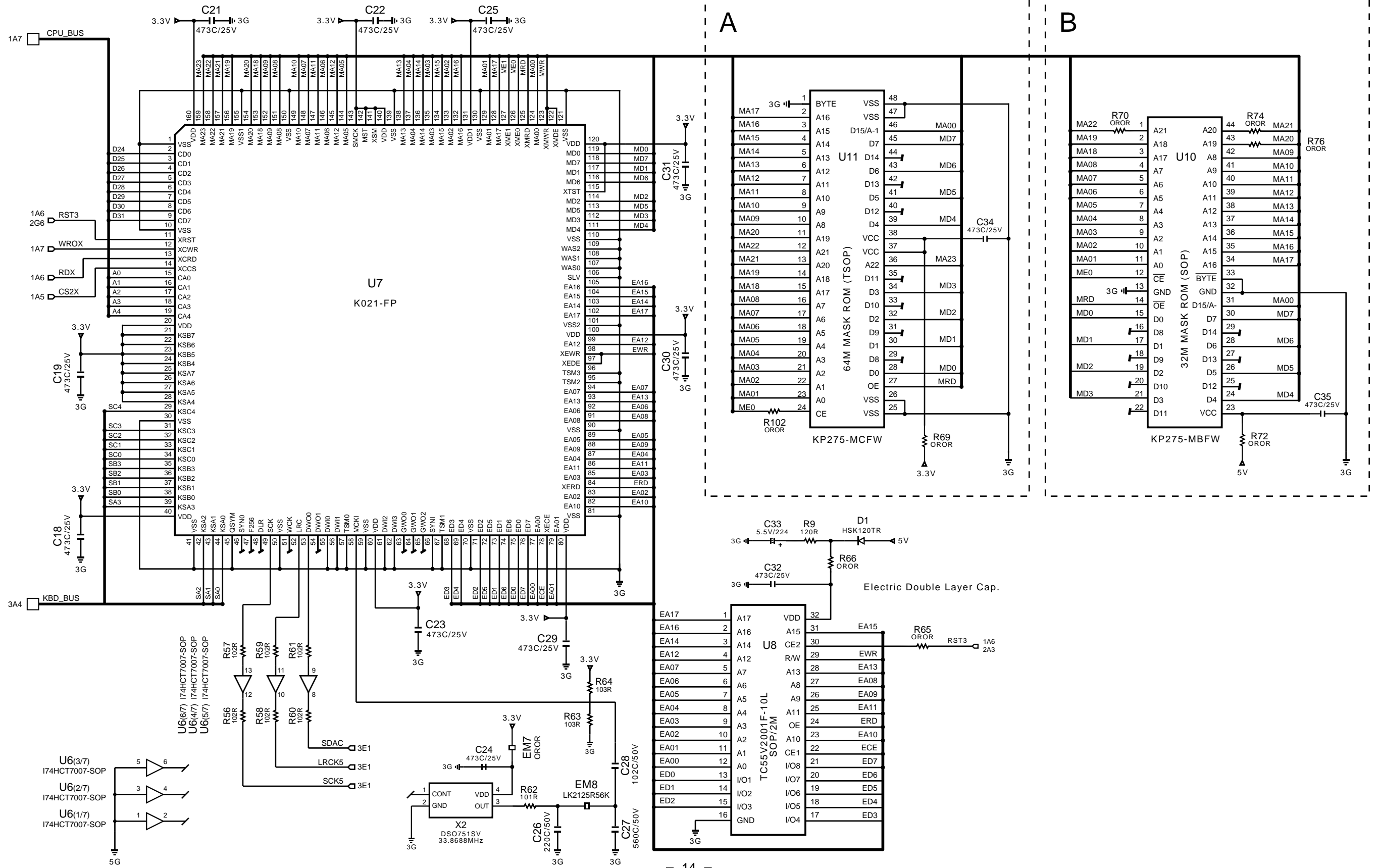

KEP-062 CIRCUIT (3/3) < CPU >

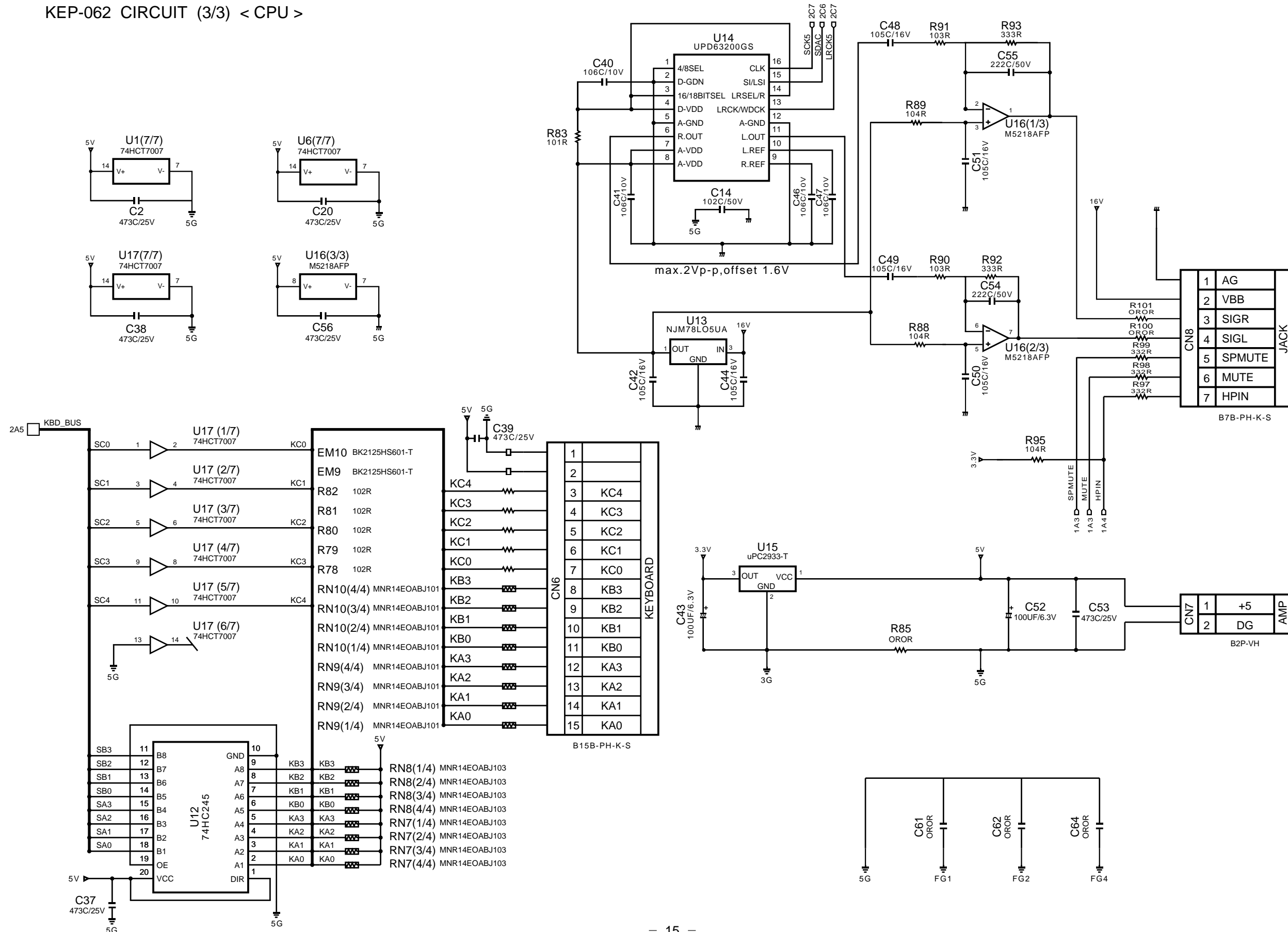

A B C D E F G H I

1
2
3
4
5
6
7

P.W.B. KEP- 096 / 097 / 098 ASSEMBLY

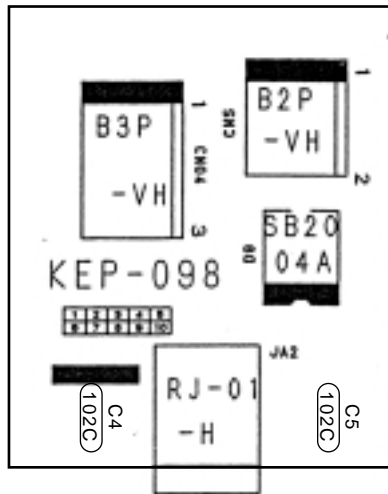
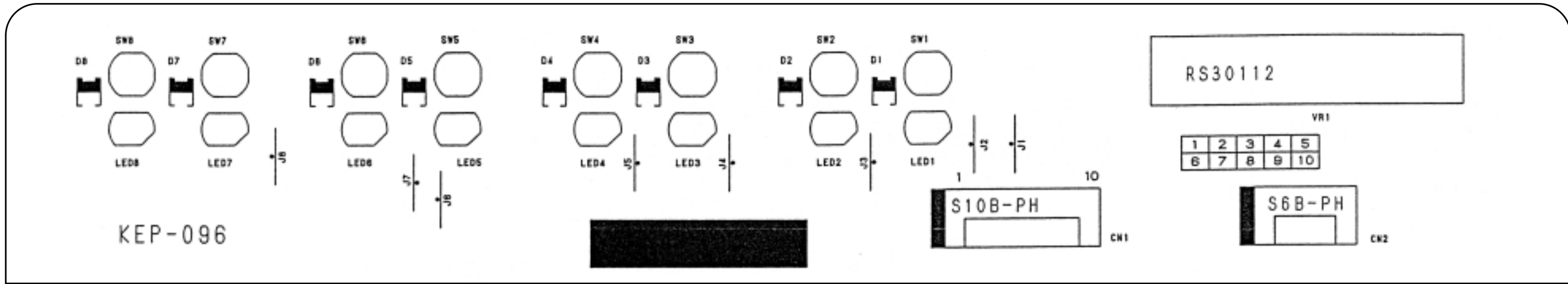

DC IN

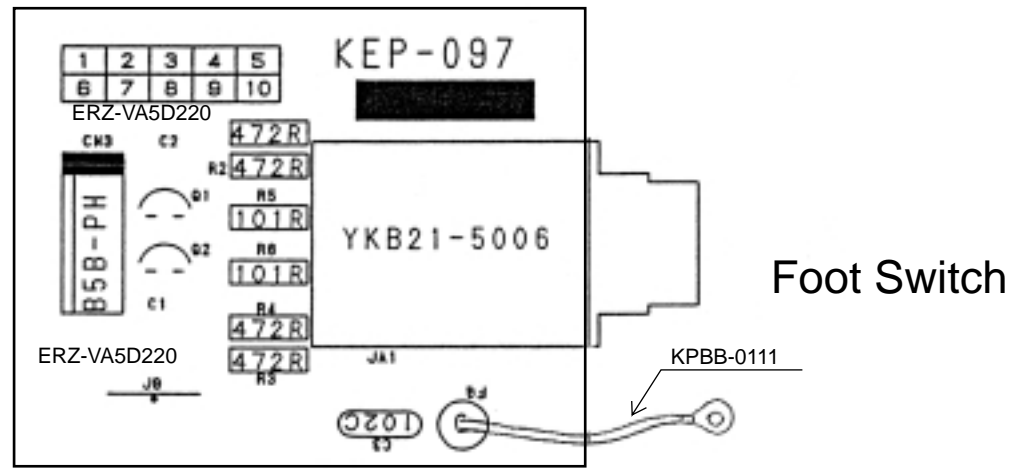

Foot Switch



P.W.B. KEP- 096 / 097 / 098 CIRCUIT

KEP-096

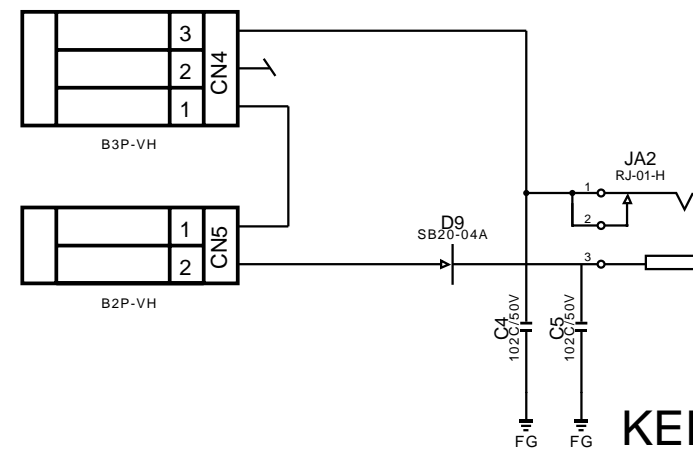
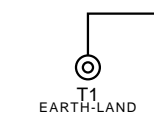
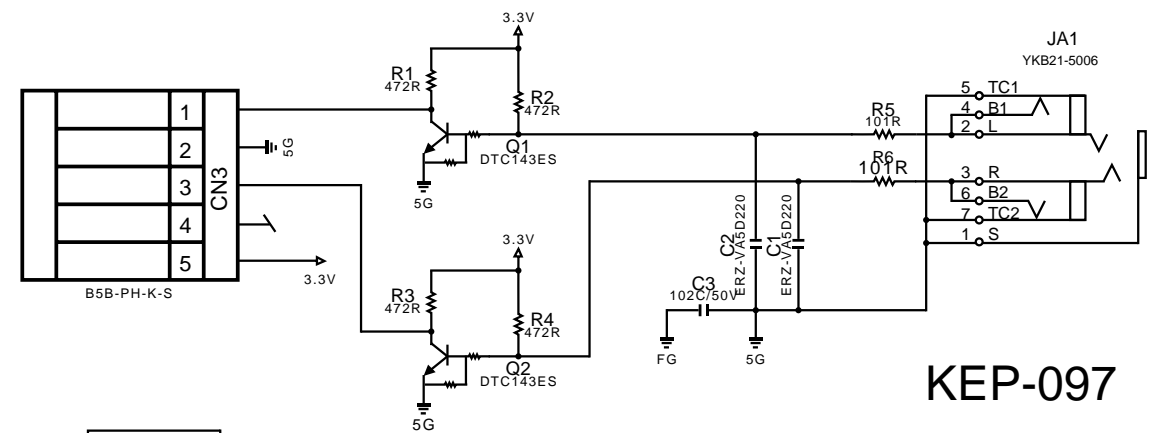
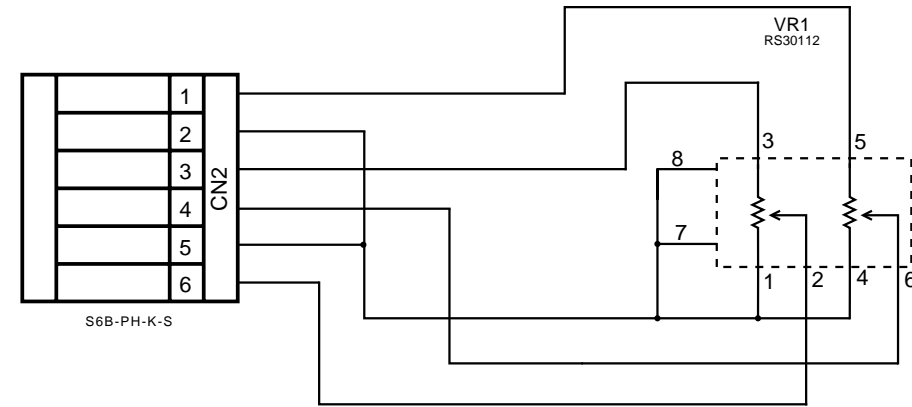
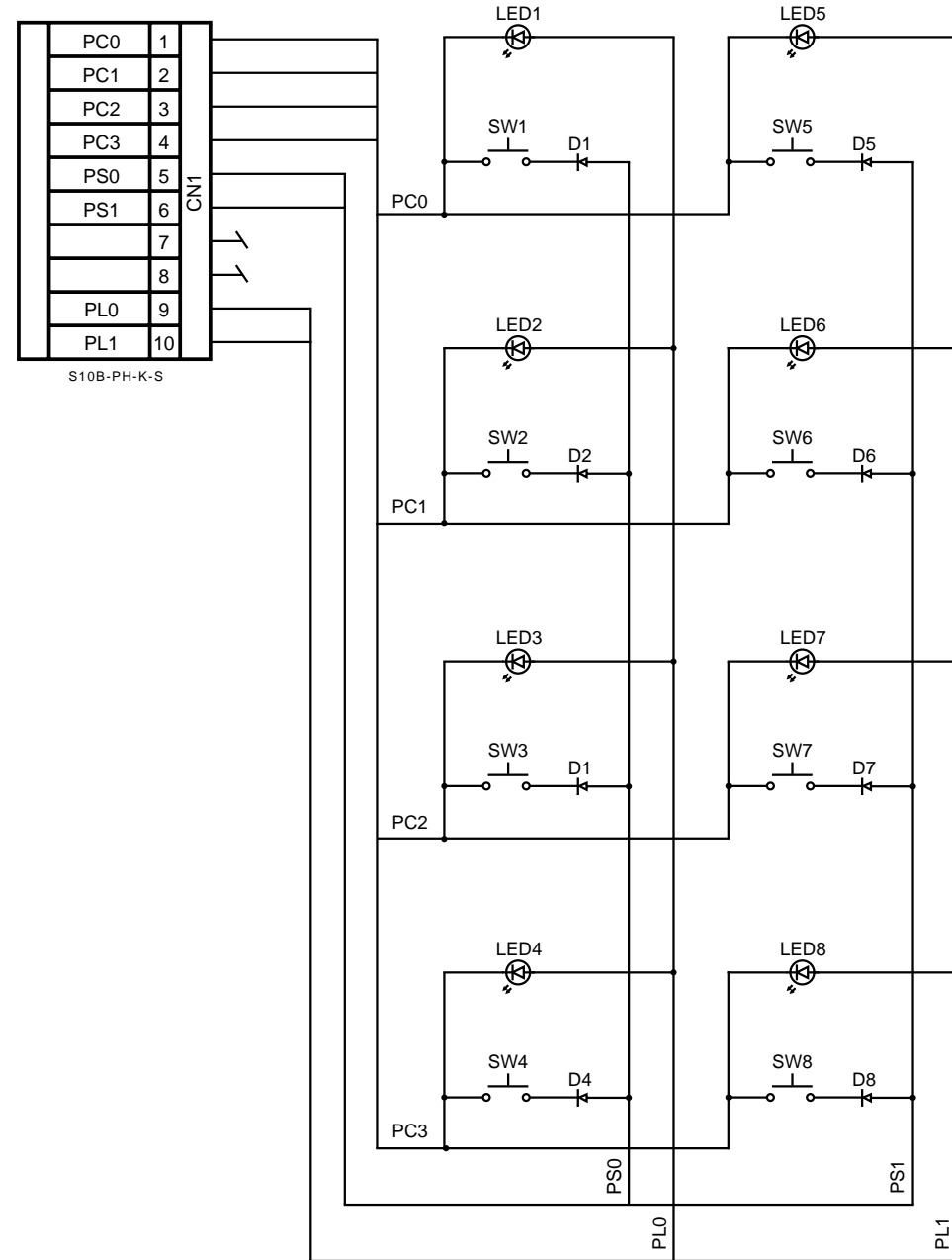

A B C D E F G H I

1
2
3
4
5
6
7

P.W.B. KEP- 064 / 065 / 066 ASSEMBLY

1
2
3
4
5
6
7

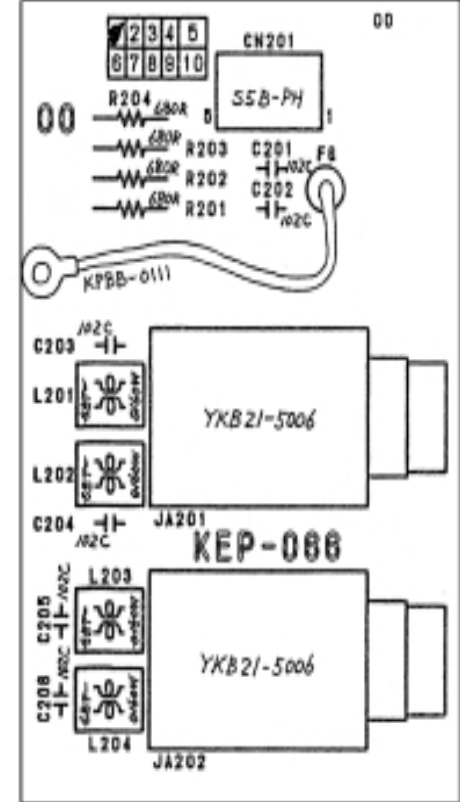
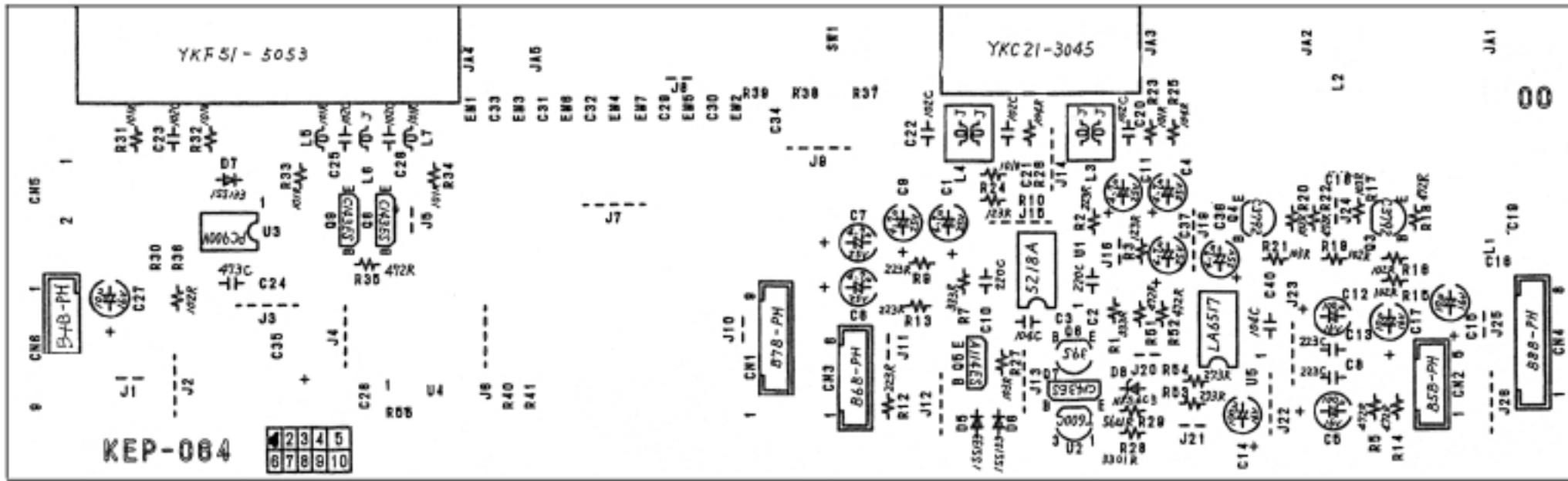
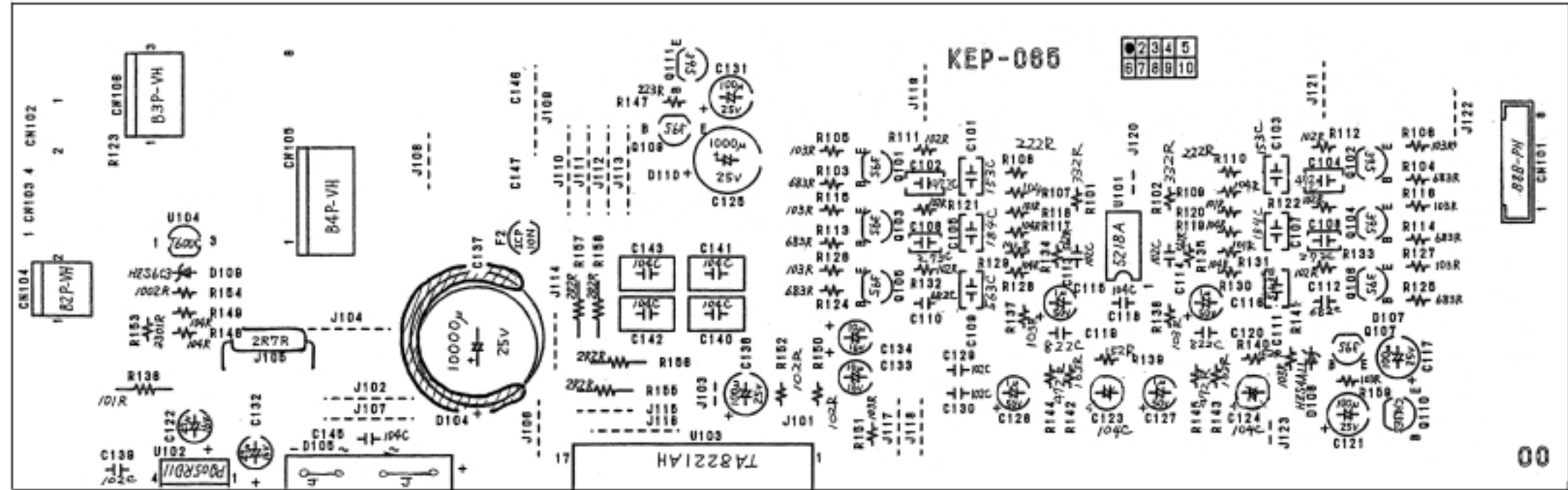

Headphone

KEP-064 / 065 ANALOG CIRCUIT (1/2)

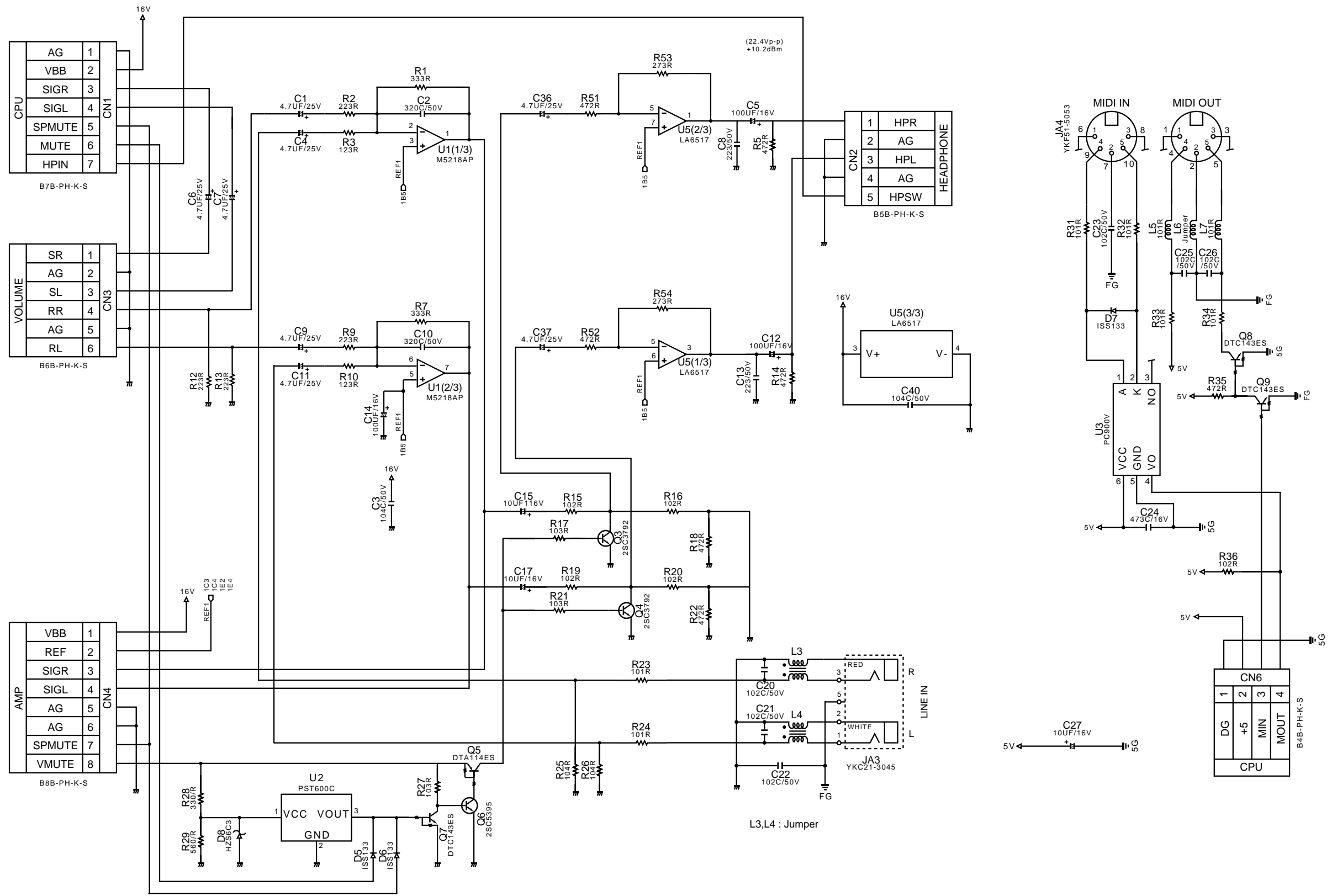

KEP-064 / 065 ANALOG CIRCUIT (2/2)

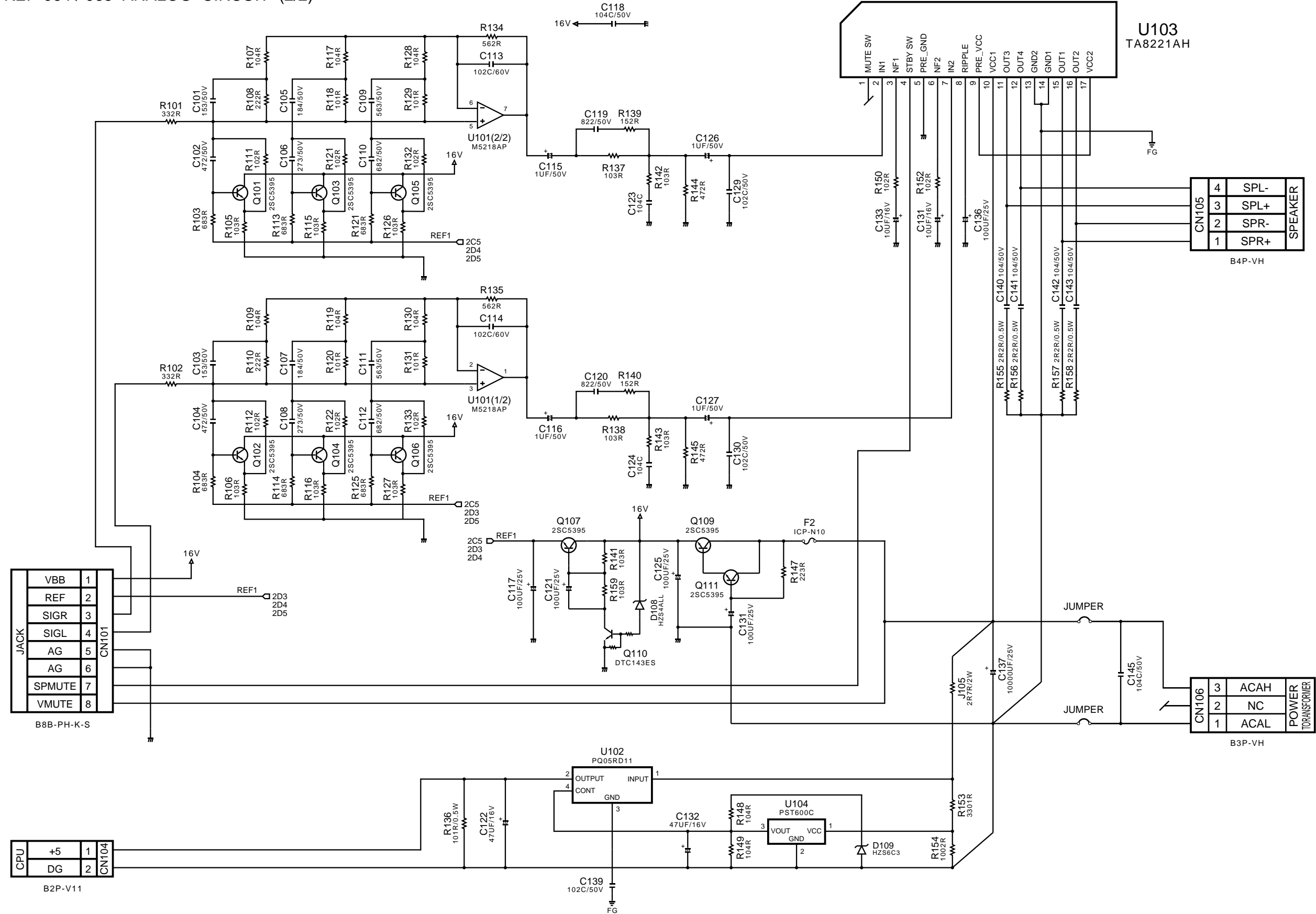

JACK CN101 B8B-PH-K-S

VBB	1
REF	2
SIGR	3
SIGL	4
AG	5
AG	6
SPMUTE	7
VMUTE	8

CPU CN104 B2P-V11

+5	1
DG	2

CN105 B4P-VH

4	SPL-
3	SPL+
2	SPR-
1	SPR+

SPEAKER

CN106 B3P-VH

3	ACAH
2	NC
1	ACAL

POWER TRANSFORMER

KEP-066 ANALOG CIRCUIT

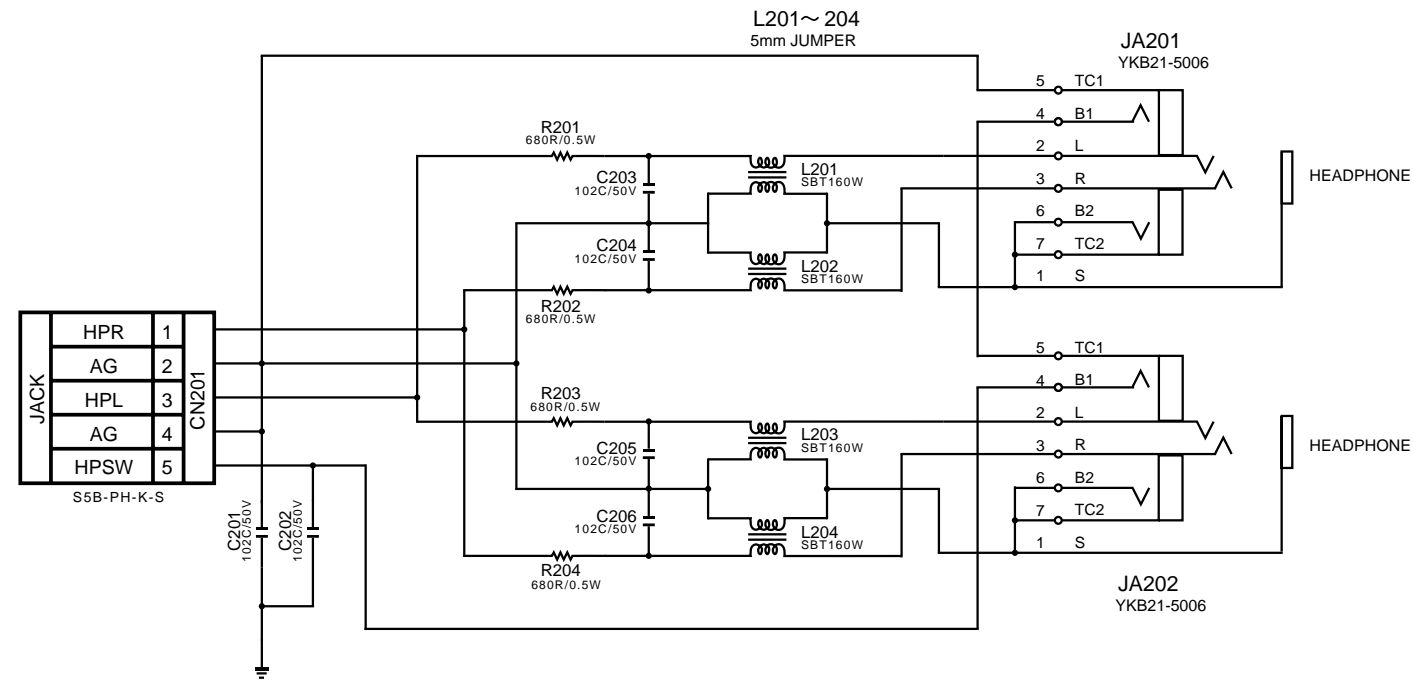

P.W.B. KKB-015 (Key switch) CIRCUIT

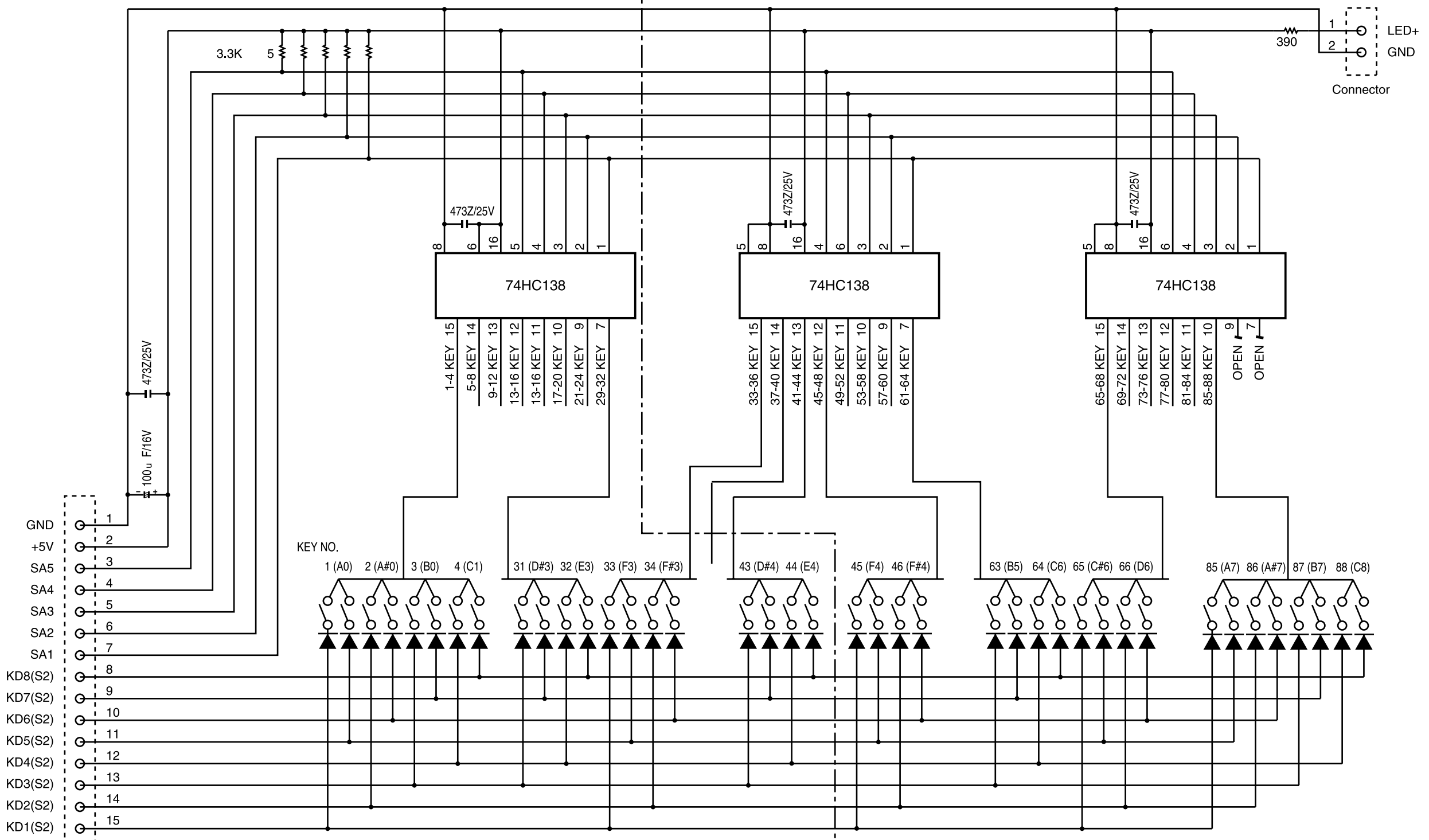

Connector KD1~KD4 First circuit (First ON, Late OFF)
 KD5~KD8 Second circuit (Late ON, First OFF)

←
→
 Switch P.W.B. B (KKB-015B) Switch P.W.B. A (KKB-015A)

SE 961 L-0211
Printed in Japan