

Service Manual

Blu-ray Disc Recorder

Model No. **DMR-BWT460GN**
DMR-BWT760GN

Colour:

(K).....Black Type



Notes: This model's BD Drive is SXY0046 (BWT460GN), SXY0042 (BWT760GN)

When replacing HDD, Main or EEPROM "HDD Error" indication is displayed and HDD must be formatted.

After that, programme in the HDD will be lost. In detail, please refer to each content in this service manual.

"AVCHD", "AVCHD 3D", "AVCHD Progressive" and "AVCHD 3D/Progressive" are trademarks of Panasonic Corporation and Sony Corporation.

Copyright 2004-2014 Verance Corporation. Cinavia™ is a Verance Corporation trademark. Protected by U.S. Patent 7,369,677 and worldwide patents issued and pending under license from Verance Corporation. All rights reserved.

DLNA, the DLNA Logo and DLNA CERTIFIED are trademarks, service marks, or certification marks of the Digital Living Network Alliance. (BWT760GN)

DVB and the DVB logos are trademarks of the DVB Project.

Manufactured under license from Dolby Laboratories.
Dolby and the double-D symbol are trademarks of Dolby Laboratories.



For DTS patents, see <http://patents.dts.com>. Manufactured under license from DTS Licensing Limited. DTS, DTS-HD, the Symbol, & DTS and the Symbol together are registered trademarks, and DTS-HD Master Audio | Essential is a trademark of DTS, Inc. © DTS, Inc. All Rights Reserved.



"DVD Logo" is a trademark of DVD Format/Logo Licensing Corporation.

MPEG Layer-3 audio coding technology licensed from Fraunhofer IIS and Thomson.

This product is licensed under the AVC patent portfolio license and VC-1 patent portfolio license for the personal and non-commercial use of a consumer to (i) encode video in compliance with the AVC Standard and VC-1 Standard ("AVC/VC-1 Video") and/or (ii) decode AVC/VC-1 Video that was encoded by a consumer engaged in a personal and non-commercial activity and/or was obtained from a video provider licensed to provide AVC/VC-1 Video. No license is granted or shall be implied for any other use. Additional information may be obtained from MPEG LA, LLC. See <http://www.mpegla.com>.

This product is licensed under the VC-1 patent portfolio license for the personal and non-commercial use of a consumer to (i) encode video in compliance with the VC-1 Standard ("VC-1 Video") and/or (ii) decode VC-1 Video that was encoded by a consumer engaged in a personal and non-commercial activity and/or was obtained from a video provider licensed to provide VC-1 video. No license is granted or shall be implied for any other use. Additional information may be obtained from MPEG LA, L.L.C. See <http://www.mpegla.com>

SDXC Logo is a trademark of SD-3C, LLC. (BWT760GN Only)

(BWT760GN Only)

The Wi-Fi CERTIFIED™ Logo is a certification mark of Wi-Fi Alliance®.
The Wi-Fi Protected Setup™ Identifier mark is a certification mark of Wi-Fi Alliance®.



(BWT760GN Only)

"Wi-Fi®" and "Wi-Fi Direct®" are registered trademarks of Wi-Fi Alliance®.
"Wi-Fi Protected Setup™", "Miracast™", "WPA™", and "WPA2™" are trademarks of Wi-Fi Alliance®.

HDMI, the HDMI Logo, and High-Definition Multimedia Interface are trademarks or registered trademarks of HDMI Licensing LLC in the United States and other countries.

Java is a registered trademark of Oracle and/or its affiliates.



(BWT760GN)

Windows is a trademark or a registered trademark of Microsoft Corporation in the United States and other countries.

(BWT760GN)

Android is a trademark of Google Inc.

This product incorporates the following software:
(1) the software developed independently by or for Panasonic Corporation,
(2) the software owned by third party and licensed to Panasonic Corporation,
(3) the software licensed under the GNU General Public License, Version 2.0 (GPL V2.0),
(4) the software licensed under the GNU LESSER General Public License, Version 2.1 (LGPL V2.1), and/or
(5) open source software other than the software licensed under the GPL V2.0 and/or LGPL V2.1.

The software categorized as (3) - (5) are distributed in the hope that it will be useful, but WITHOUT ANY WARRANTY, without even the implied warranty of MERCHANTABILITY or FITNESS FOR A PARTICULAR PURPOSE. Please refer to the detailed terms and conditions thereof shown in the Basic Settings menu.

At least three (3) years from delivery of this product, Panasonic will give to any third party who contacts us at the contact information provided below, for a charge no more than our cost of physically performing source code distribution, a complete machine-readable copy of the corresponding source code covered under GPL V2.0, LGPL V2.1 or the other licenses with the obligation to do so, as well as the respective copyright notice thereof.
Contact Information: oss-cd-request@gg.jp.panasonic.com

The source code and the copyright notice are also available for free in our website below.
<http://panasonic.net/avc/oss/>

MS/PlayReady/Final Product Labeling
This product contains technology subject to certain intellectual property rights of Microsoft. Use or distribution of this technology outside of this product is prohibited without the appropriate license(s) from Microsoft.

MS/PlayReady/End User Notices
Content owners use Microsoft PlayReady™ content access technology to protect their intellectual property, including copyrighted content. This device uses PlayReady technology to access PlayReady-protected content and/or WMDRM-protected content. If the device fails to properly enforce restrictions on content usage, content owners may require Microsoft to revoke the device's ability to consume PlayReady-protected content.
Revocation should not affect unprotected content or content protected by other content access technologies. Content owners may require you to upgrade PlayReady to access their content. If you decline an upgrade, you will not be able to access content that requires the upgrade.

Vorbis, FLAC, (WPA Supplicant For BWT760GN)
The software licenses are displayed when "Software Licence" in the Basic Settings menu is selected.

 **WARNING**

This service information is designed for experienced repair technicians only and is not designed for use by the general public. It does not contain warnings or cautions to advise non-technical individuals of potential dangers in attempting to service a product. Products powered by electricity should be serviced or repaired only by experienced professional technicians. Any attempt to service or repair the product or products dealt with in this service information by anyone else could result in serious injury or death.

TABLE OF CONTENTS

	PAGE	PAGE
1 Safety Precautions	5	
1.1. General Guidelines	5	
2 Warning	6	
2.1. Prevention of Electro Static Discharge (ESD) to Electrostatically Sensitive (ES) Devices	6	
2.2. Precaution of Laser Diode	7	
2.3. Service caution based on Legal restrictions	8	
3 Service Navigation	9	
3.1. External HDD (USB HDD)	9	
3.2. How to format for HDD when replacement of HDD or Main P.C.B.	12	
3.3. Combination of Multiple Pressing on the Remote Control	13	
3.4. Entering Special Modes with Combination of Multiple Pressing on the Remote Control	13	
3.5. Micro Fuse conducting check	15	
3.6. Operation check when a USB device is connected	16	
3.7. (HDD/BD Drive) Service Navigation	17	
3.8. Wi-Fi Module (Internal) Malfunction Check (Simplified Method) (BWT760GN Only)	19	
3.9. Check with Tuner Service Mode	21	
3.10. Description of the Self Diagnosis <Operation Method, Details>	25	
4 Specifications	31	
5 Location of Controls and Components	33	
6 Installation Instructions	37	
6.1. Taking out the Disc from BD-Drive Unit when the Disc cannot be ejected by [OPEN/CLOSE] button	37	
7 Service Mode	38	
7.1. Self-Diagnosis and Special Mode Setting	38	
8 Service Fixture & Tools	58	
9 Disassembly and Assembly Instructions	59	
9.1. DMR-BWT460GN	59	
9.2. DMR-BWT760GN	64	
9.3. BD Drive	69	
10 Measurements and Adjustments	75	
10.1. Service Positions	75	
10.2. Caution for Replacing Parts	82	
10.3. Standard Inspection Specifications after Making Repairs	83	
11 Block Diagram	84	
11.1. Power Supply Block Diagram	84	
11.2. Power Supply Block Diagram	85	
12 Wiring Connection Diagram	86	
12.1. Interconnection Schematic Diagram	86	
13 Schematic Diagram	87	
14 Printed Circuit Board	87	
15 Exploded View and Replacement Parts List	87	

1 Safety Precautions

1.1. General Guidelines

1. When servicing, observe the original lead dress. If a short circuit is found, replace all parts which have been overheated or damaged by the short circuit.
2. After servicing, see to it that all the protective devices such as insulation barriers, insulation papers shields are properly installed.
3. After servicing, make the following leakage current checks to prevent the customer from being exposed to shock hazards.

1.1.1. Leakage Current Cold Check

1. Unplug the AC cord and connect a jumper between the two prongs on the plug.
2. Measure the resistance value, with an ohmmeter, between the jumpered AC plug and each exposed metallic cabinet part on the equipment such as screwheads, connectors, control shafts, etc. When the exposed metallic part has a return path to the chassis, the reading should be between $1M\Omega$ and $5.2M\Omega$.

When the exposed metal does not have a return path to the chassis, the reading must be ∞ .

1.1.2. Leakage Current Hot Check (See Figure 1.)

1. Plug the AC cord directly into the AC outlet. Do not use an isolation transformer for this check.
2. Connect a $1.5k\Omega$, 10 watts resistor, in parallel with a $0.15\mu F$ capacitors, between each exposed metallic part on the set and a good earth ground such as a water pipe, as shown in Figure 1.
3. Use an AC voltmeter, with 1000 ohms/volt or more sensitivity, to measure the potential across the resistor.
4. Check each exposed metallic part, and measure the voltage at each point.
5. Reverse the AC plug in the AC outlet and repeat each of the above measurements.
6. The potential at any point should not exceed 0.75 volts RMS. A leakage current tester (Simpson Model 229 or equivalent) may be used to make the hot checks, leakage current must not exceed 1/2 milliamp. In case a measurement is outside of the limits specified, there is a possibility of a shock hazard, and the equipment should be repaired and re-checked before it is returned to the customer.

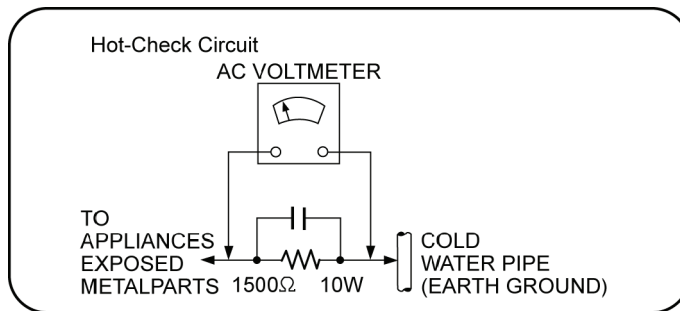

Fig. 1

2 Warning

2.1. Prevention of Electro Static Discharge (ESD) to Electrostatically Sensitive (ES) Devices

Some semiconductor (solid state) devices can be damaged easily by static electricity. Such components commonly are called Electrostatically Sensitive (ES) Devices. Examples of typical ES devices are integrated circuits and some field-effect transistors and semiconductor “chip” components. The following techniques should be used to help reduce the incidence of component damage caused by electrostatic discharge (ESD).

1. Immediately before handling any semiconductor component or semiconductor-equipped assembly, drain off any ESD on your body by touching a known earth ground. Alternatively, obtain and wear a commercially available discharging ESD wrist strap, which should be removed for potential shock reasons prior to applying power to the unit under test.
2. After removing an electrical assembly equipped with ES devices, place the assembly on a conductive surface such as aluminium foil, to prevent electrostatic charge build up or exposure of the assembly.
3. Use only a grounded-tip soldering iron to solder or unsolder ES devices.
4. Use only an anti-static solder remover device. Some solder removal devices not classified as “anti-static (ESD protected)” can generate electrical charge sufficient to damage ES devices.
5. Do not use freon-propelled chemicals. These can generate electrical charges sufficient to damage ES devices.
6. Do not remove a replacement ES device from its protective package until immediately before you are ready to install it. (Most replacement ES devices are packaged with leads electrically shorted together by conductive foam, aluminium foil or comparable conductive material).
7. Immediately before removing the protective material from the leads of a replacement ES device, touch the protective material to the chassis or circuit assembly into which the device will be installed.

Caution:

Be sure no power is applied to the chassis or circuit, and observe all other safety precautions.

8. Minimize bodily motions when handling unpackaged replacement ES devices. (Otherwise harmless motion such as the brushing together of your clothes fabric or the lifting of your foot from a carpeted floor can generate static electricity sufficient to damage an ES device).

IMPORTANT SAFETY NOTICE

There are special components used in this equipment which are important for safety. These parts are marked by Δ in the schematic diagrams, Exploded Views and replacement parts list. It is essential that these critical parts should be replaced with manufacturer's specified parts to prevent shock, fire, or other hazards. Do not modify the original design without permission of manufacturer.

2.2. Precaution of Laser Diode

CAUTION :

This product utilizes a laser diode with the unit turned "ON", invisible laser radiation is emitted from the pick up lens.

Wave length : 661 nm(DVDs)/783 nm(CDs)/405nm(BDs)

Maximum output radiation power from pick up : 100 μ W/VDE

Laser radiation from pickup unit lens is safety level, but be sure the followings:

1. Do not disassemble the optical pickup unit, since radiation from exposed laser diode is dangerous.
2. Do not adjust the variable resistor on the pickup unit. It was already adjusted.
3. Do not look at the focus lens using optical instruments.
4. Recommend not to look at pickup lens for a long time.

ACHTUNG :

Dieses Produkt enthält eine Laserdiode. Im eingeschalteten Zustand wird unsichtbare Laserstrahlung von der Lasereinheit abgestrahlt.

Wellenlänge : 661 nm(DVDs)/783 nm(CDs)/405nm(BDs)

Maximale Strahlungsleistung der Lasereinheit : 100 μ W/VDE

Die Strahlung der Lasereinheit ungefährlich, wenn folgende Punkte beachtet werden:

1. Die Lasereinheit nicht zerlegen, da die Strahlung an der freigelegten Laserdiode gefährlich ist.
2. Den werkseitig justierten Einstellregler der Lasereinheit nicht verstellen.
3. Nicht mit optischen Instrumenten in die Fokussierlines blicken.
4. Nicht über längere Zeit in die Fokussierlines blicken.

(BWT760GN)

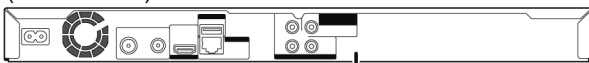

(BWT460GN)

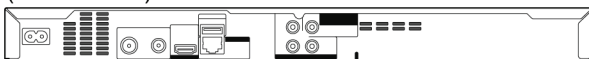

DANGER	VISIBLE AND INVISIBLE LASER RADIATION WHEN OPEN. AVOID DIRECT EXPOSURE TO BEAM. FDA21 CFR CLASS IIIb IEC60825-1 CLASS 3B
CAUTION	CLASS 3B VISIBLE AND INVISIBLE LASER RADIATION WHEN OPEN. AVOID EXPOSURE TO THE BEAM. IEC60825-1 CLASS 3B
ATTENTION	RAYONNEMENT LASER VISIBLE ET INVISIBLE, CLASSE 3B, EN CAS D'OUVERTURE. EVITER UNE EXPOSITION AU FAISCEAU.
FORSIGTIG	SYNLIG OG USYNLIG LASERSTRÅLING KLASSE 3B. NÅR LÅGET ER ÅBENT, UNDGÅ AT BLIVE UDSAT FOR STRÅLEN.
VARO	AVATTARESSA OLET ALTTIINA LUOKAN 3B NÄKYVÄÄ JA NÄKYMÄTÖNTÄ LASERSÄTEILYÄ. VARO ALTISTUMISTA SÄTEELLE.
VARNING	KLASS 3B SYNLIG OCH OSYNLIG LASERSTRÅLNING NÄR DENNA DEL ÄR ÖPPNAD. UNDVIK EXPONERING FÖR STRÅLEN.
VORSICHT	SICHTBARE UND UNSICHTBARE LASERSTRAHLUNG KLASSE 3B. WENN ABDECKUNG GEÖFFNET, NICHT DEM STRAHL AUSSETZEN.
注意	打开时有可见及不可见激光辐射。避免光束照射。
注意	ここを開くとクラス3Bの可視及び不可視レーザー放射が出る。ビームの目又は皮膚への照射は危険! 死んだり焼けたりしないこと
	VQL2Q40

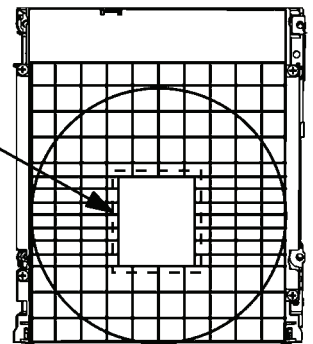

CAUTION!
THIS PRODUCT UTILIZES A LASER.
USE OF CONTROLS OR ADJUSTMENTS OR PERFORMANCE OF PROCEDURES OTHER THAN THOSE SPECIFIED HEREIN MAY RESULT IN HAZARDOUS RADIATION EXPOSURE.

2.3. Service caution based on Legal restrictions

2.3.1. General description about Lead Free Solder (PbF)

The lead free solder has been used in the mounting process of all electrical components on the printed circuit boards used for this equipment in considering the globally environmental conservation.

The normal solder is the alloy of tin (Sn) and lead (Pb). On the other hand, the lead free solder is the alloy mainly consists of tin (Sn), silver (Ag) and Copper (Cu), and the melting point of the lead free solder is higher approx.30 degrees C (86°F) more than that of the normal solder.

Definition of PCB Lead Free Solder being used

The letter of "PbF" is printed either foil side or components side on the PCB using the lead free solder. (See right figure)	PbF
---	------------

Service caution for repair work using Lead Free Solder (PbF)

- The lead free solder has to be used when repairing the equipment for which the lead free solder is used.
(Definition: The letter of "PbF" is printed on the PCB using the lead free solder.)
- To put lead free solder, it should be well molten and mixed with the original lead free solder.
- Remove the remaining lead free solder on the PCB cleanly for soldering of the new IC.
- Since the melting point of the lead free solder is higher than that of the normal lead solder, it takes the longer time to melt the lead free solder.
- Use the soldering iron (more than 70W) equipped with the temperature control after setting the temperature at 350±30 degrees C (662±86°F).

Recommended Lead Free Solder (Service Parts Route.)

- The following 3 types of lead free solder are available through the service parts route.
SVKZ000004-----(0.3mm 100g Reel)
SVKZ000005-----(0.6mm 100g Reel)
SVKZ000006-----(1.0mm 100g Reel)

Note

* Ingredient: Tin (Sn), 96.5%, Silver (Ag) 3.0%, Copper (Cu) 0.5%, Cobalt (Co) / Germanium (Ge) 0.1 to 0.3%

3 Service Navigation

3.1. External HDD (USB HDD)

Please use a confirmed USB HDD

For the latest information on confirmed USB HDDs, please check the following website.
<http://panasonic.jp/support/global/cs/>

- Certain non-confirmed USB HDDs cannot be used with this unit.
- If a problem occurs with the USB HDD, please contact the manufacturer of the device.

3.1.1. Connecting the USB HDD

Connect this unit with optional USB HDD.

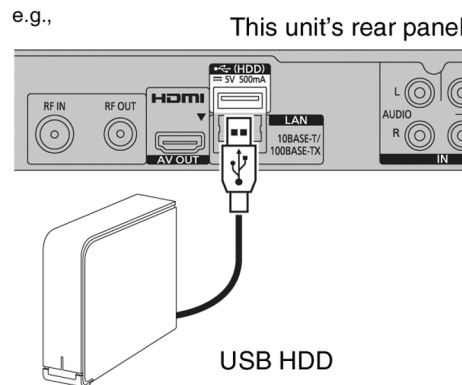

- Only one USB HDD can be connected at the same time.
- Do not connect additional HDDs using a USB hub.
- For details about connection method, refer to the instructions supplied with the USB HDD.

3.1.2. Disconnecting the USB HDD

Please use the following procedure to disconnect.

Disconnecting without following this procedure may result in the loss of recorded content from the USB HDD or the internal HDD.

1. Press [FUNCTION MENU].
2. Select "Basic Settings" in "Setup", then press [OK].
3. Select "Settings for USB HDD" in "HDD/ Disc/ USB HDD", then press [OK].
4. Select "USB HDD Disconnection", then press [OK].
5. Select "Yes", then press [OK].
6. Disconnect the USB HDD from this unit.

3.1.3. Registering the USB HDD

3.1.3.1. Registering the USB HDD

- If you intend to move recorded titles to a USB HDD, the USB HDD must be registered to this unit first.

Limitation information:

- A USB HDD with a capacity of less than 160 GB cannot be used.
- Registering of a USB HDD will format the USB HDD and all the content already recorded will be deleted.
- Up to eight USB HDDs can be registered on this unit.
- Registered USB HDDs cannot be used with devices other than this unit.

- If the registering screen appears when connecting the USB HDD, go to step 5.

1. Press [FUNCTION MENU].
2. Select "Basic Settings" in "Setup", then press [OK].
3. Select "Settings for USB HDD" in "HDD/ Disc/ USB HDD", then press [OK].
4. Select "USB HDD Registration", then press [OK].
5. Select "Yes", then press [OK].

- If you have already registered eight USB HDDs, it will be necessary to delete one or more of them before registering a new USB HDD.

The message screen appears:

- a. Select "Yes", then press [OK].
- b. Select the USB HDD to cancel, then press [OK]. The confirmation screen appears.

- c. Select "Yes", then press [OK].
6. When the registering is complete, message screen appears.
Press [OK].
7. The confirmation screen appears.
Press [OK].

3.1.3.2. Settings for USB HDD

Delete all titles

Delete all titles on the USB HDD.

- Delete does not work if one or more titles are protected.

1. Press [FUNCTION MENU].
2. Select "Basic Settings" in "Setup", then press [OK].
3. Select "Settings for USB HDD" in "HDD/ Disc/ USB HDD", then press [OK].
4. Select "USB HDD Management", then press and hold [OK] for 3 seconds.
5. Select "Delete all titles", then press [OK].
6. Select "Yes" and press [OK].
7. Select "Start" and press [OK].
8. The confirmation screen appears, then press [OK].

Format USB HDD

Formatting deletes all contents, and they cannot be restored.

- Check carefully before proceeding.

1. Press [FUNCTION MENU].
2. Select "Basic Settings" in "Setup", then press [OK].
3. Select "Settings for USB HDD" in "HDD/ Disc/ USB HDD", then press [OK].
4. Select "USB HDD Management", then press and hold [OK] for 3 seconds.
5. Select "Format USB HDD", then press [OK].
6. Select "Yes" and press [OK].
7. Select "Start" and press [OK]. Then formatting starts.
8. Press [OK] after formatting completed.

3.1.3.3. To cancel all USB HDD registrations

- If you register a USB HDD, all the content already recorded on the USB HDD will be deleted.
- It is not possible to play back the content on the USB HDD whose registration has been cancelled.
- You can check the registration number of the USB HDD on the DIRECT NAVIGATOR.

Cancellation of all USB HDD Registrations

This function cancels the registrations of all the USB HDDs registered on this unit.

Only do this if you are going to dispose of this unit.

- Before operation, perform "3.1.2. Disconnecting the USB HDD" and remove the USB HDD.
- It is not possible to play back the content from a USB HDD whose registration has been cancelled.

1. Press [FUNCTION MENU].
2. Select "Basic Settings" in "Setup", then press [OK].
3. Select "Settings for USB HDD" in "HDD/ Disc/ USB HDD", then press [OK].
4. Select "Cancellation of all USB HDD Registrations", then press and hold [OK] for 3 seconds.
5. Select "Yes", then press [OK].
6. The confirmation screen appears.
Select "Yes", and press [OK].
7. When the cancellation is complete, message screen appears.
Press [OK].

3.1.3.4. Registration procedure for USB HDD for inspection

This function registers a USB HDD for inspection aside from 8 USB HDDs that can be registered in Normal mode.

If the USB HDD for inspection is registered in User mode, it cannot be erased. Make sure to use Special mode to register the USB HDD for inspection.

Registration procedure

1. Perform "3.4.3. Nondisclosure mode 2" to enter the Service mode.
2. Press the [7][4] buttons of remote control in the Service mode to enter the Special mode.
3. If the new USB HDD is connected, it is automatically formatted/registered. (There is no TV monitor display for registration.)
The USB HDD registered in the Special mode can be operated using the same functions (format, record/play/edit, dubbing) as those for USB HDDs registered in the Normal mode.
The Special mode can be cancelled at power "OFF" only. (Cancelling the Special mode will erase the registration in the Special mode.)

3.1.4. Operation check when USB HDD is connected

Check the operation status (normal or abnormal) of the USB connection part as follows.

1. Press [FUNCTION MENU].
2. Select "Basic Settings" in "Setup", then press [OK].
3. Select "Settings for USB HDD" in "HDD/ Disc/ USB HDD", then press [OK].
4. Select "USB HDD Registration", then press [OK].

Normal operation:

The registered USB HDD is automatically displayed when connected.

(*Displayed items differ depending on the connected USB HDD.)

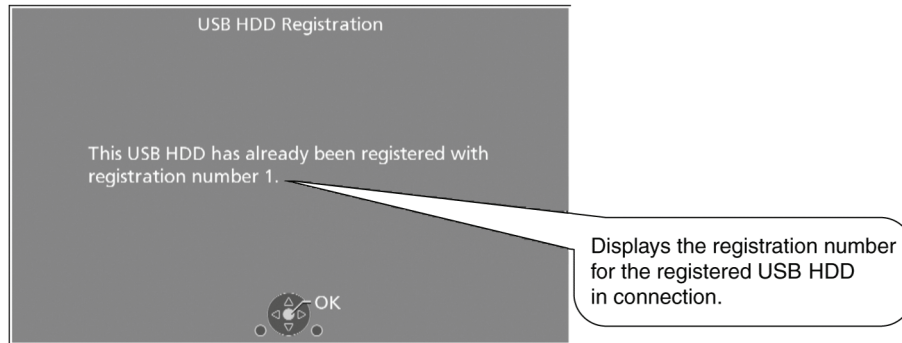

Abnormal operation (1):

When the USB HDD cannot be detected, "Cannot detect USB HDD." etc. will be automatically displayed.

(*When the cable (USB cable) between the main unit and the USB HDD is poorly connected (cable disconnection), etc.)

Abnormal operation (2):

When a wrong USB HDD incompatible with this unit is connected, "Connected USB device cannot be used with this unit.", etc. will be automatically displayed.

(*Incompatible USB HDD: When devices with capacity of less than 160GB or more than 2TB or other USB devices are connected)

Abnormal operation (3):

When more than 1 USB HDD are connected at the same time, "Registration of USB HDD must be done with only one USB storage device connected.", etc. will be automatically displayed.

Abnormal operation (4):

When a USB HDD compatible only with USB 1.1 or below is connected, "Connected USB device cannot be used with this unit.", etc. will be automatically displayed.

3.2. How to format for HDD when replacement of HDD or Main P.C.B.

3.2.1. How to escape "HDD Error" indication on GUI display.

1. When exchange HDD or Main P.C.B., the "HDD Error" screen is displayed, but, according to a following procedure, please format HDD.

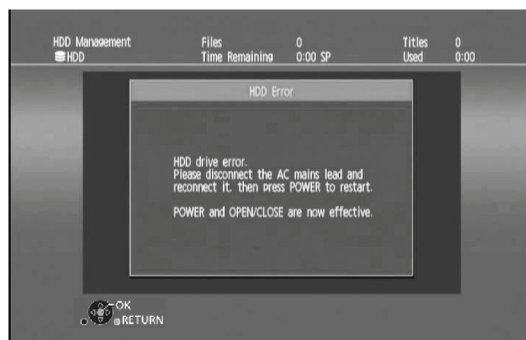

2. Turn off the power button first, then turn on the power with the "GUIDE" button on remote-controller. (Shown in Reference screen 1)



Reference screen 1

3. Turn on the "RETURN" button next, move to the normal display.

3.2.2. Procedure of the "HDD format".

1. Press [FUNCTION MENU].
2. Select " Setup " and press [OK].
3. Select " Basic Settings " and press [OK].
4. Select "HDD / Disc / USB HDD" and press [OK].
5. Select " HDD Management " and press [OK] for 3 seconds.
6. Select " Format HDD " and press [OK].
7. Select " Yes " and press [OK].
8. Select " Start " and press [OK]. Then formatting starts.
9. Press [OK] after formatting completed.
10. Press [RETURN] to exit Settings mode.

3.3. Combination of Multiple Pressing on the Remote Control

Press multi-buttons (in combination) on the remote control simultaneously for operations, such as initialization or service mode, etc. There are no multiple pressing functions on the previous remote controls, thus, please be sure to use the supplied remote control.

3.4. Entering Special Modes with Combination of Multiple Pressing on the Remote Control

Enter the following special modes by multiple pressing functions on the supplied remote control. After entering each mode, switch to the desired menus for operation.

Disclosure mode	Nondisclosure mode 1	Nondisclosure mode 2
[OK] [Blue] [Yellow]	[6] [7] [Yellow]	[5] [9] [Red]

◆ **Menu switch:** ↓ mark.
[▶] (remote control),
or
[Power] (main unit)

◆ **Operating menu:**
[OK] (remote control)
or
[O/C] (main unit)

✳ Release from special modes automatically after the operation.

◆ **Release from special modes:**

- Press other buttons in no connection with the above operations.
- No operation for over 2 min.
- Press and hold [Power] on main unit (forced to turn off).

3.4.1. Disclosure mode (Combination of multiple pressing: [OK] [Blue] [Yellow])

Press and hold [OK] [Blue] [Yellow] on the remote control simultaneously for 5 sec., then "00 RET" is displayed on FL display window.

Power	Disc	FL display	Key operation	Function	Remarks
OFF	Yes/No	00 RET	No	No	
		↓	06 FT0	OK	Force tray open
ON	Yes/No	00 RET	No	No	
	No	03 VL	OK	Release from BD/DVD video play restriction	Release from the aging restriction on BD video and DVD video play.
	Yes/No	04 PRG	OK (Press and hold)	Progressive initialization	Initialize the progressive settings, and switch to the interlaced display. Press and hold [STOP] (not [OK]) (on the remote control or main unit) to switch to "10 OCL" (setting shop lock mode)
	Yes/No	05 P/N	OK (Press and hold)	Switch the TV System	It returns to the default side (PAL). The change of PAL and NTSC can be performed in the following procedure. The unit's TV System is different from that of the disc. While stopped, keep pressing [STOP] and [OPEN/CLOSE] on the main unit for 5 or more seconds. The system switches from PAL to NTSC or vice versa.
	Yes/No	07 DC	OK (Press and hold)	Deep Color initialization	Initialize Deep Color.
	Yes	10 OCL	OK	Shop lock mode setting/release ([O/C] is invalid/valid, while setting/release this mode.)	When "04 PRG" is displayed, press and hold [STOP] (on the remote control or main unit) to switch to other displays. Press [OK] to only lock the tray switch. *Even turn ON/OFF the power, it is still in locking.

3.4.2. Nondisclosure mode 1 (Combination of multiple pressing: [6] [7] [Yellow])

Press and hold [6] [7] [Yellow] on the remote control simultaneously for 5 sec., then "50 RET" is displayed on FL display window.

Power	Disc	FL display	Key operation	Function	Remarks
ON	Yes/No	50 RET	No	No	
		↓			
		51 NOP	OK	No	When "51 NOP" is displayed, press and hold [STOP] (on the remote control or main unit) to switch to "52 BRE" (delete BD-ROM history settings)
		52 BRE	OK	BD-ROM history delete	When "51 NOP" is displayed, press and hold [STOP] (on the remote control or main unit) to switch to other displays. Press [OK] to delete BD-ROM history settings.

3.4.3. Nondisclosure mode 2 (Combination of multiple pressing: [5] [9] [Red])

Press and hold [5] [9] [Red] on the remote control simultaneously for about 5 sec., then "70 RET" is displayed on FL display window.

Power	Disc	FL display	Key operation	Function	Remarks
OFF	Yes/No	70 RET	No	No	
		↓			
		80 SRV	OK	Switch to service mode	Press [OK], then "HELLO" is displayed, and wait about 30 sec. until "SERV" is displayed.
		↓			
		83 SDI	OK	CD/SD Diag	Do not apply in normal service.
ON	Yes/No	91 SPD	OK	Special display	Do not apply in normal service.
		↓			
		92 F99	OK	F99 Validate/Invalidate switch	Do not apply in normal service.
		↓			
		70 RET	No	No	
		↓			
		81 AIG	OK	Switch to aging mode	
		↓			
82 TSR	OK	Switch to tuner service mode			
↓					
83 SDI	OK	CD/SD Diag	Do not apply in normal service.		
↓					
91 SPD	OK	Special display	Do not apply in normal service.		
↓					
92 F99	OK	F99 Validate/Invalidate switch	Do not apply in normal service.		
↓					
93 FIN	OK (Press and hold)	CS reset	Press [OK], then "FACT" is displayed, and the power will turn off automatic.		
↓					
96 DIC	OK	Diagnosis Code display	Press [OK], then "Diagnosis in progress. Please Wait." is displayed, and the Diagnosis Code will be displayed.		

3.5. Micro Fuse conducting check

This unit uses the Micro Fuse.

Check the Micro Fuse conducting using the Tester at the check points below.

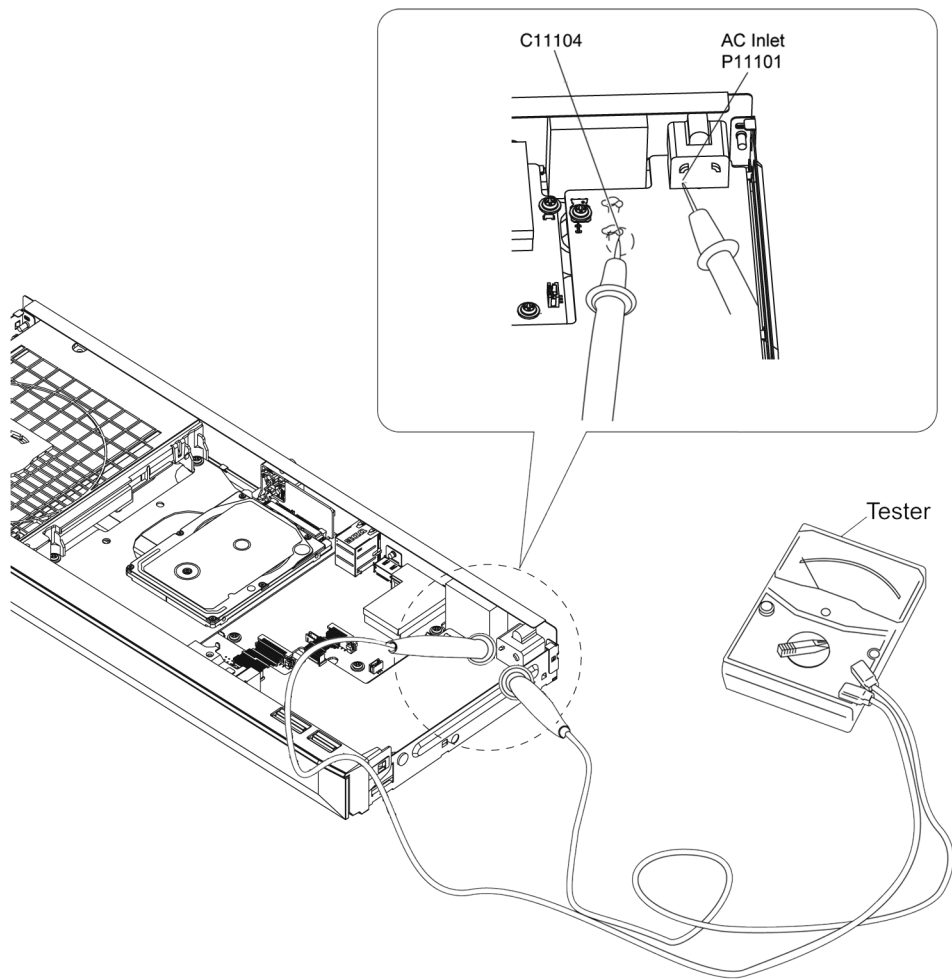
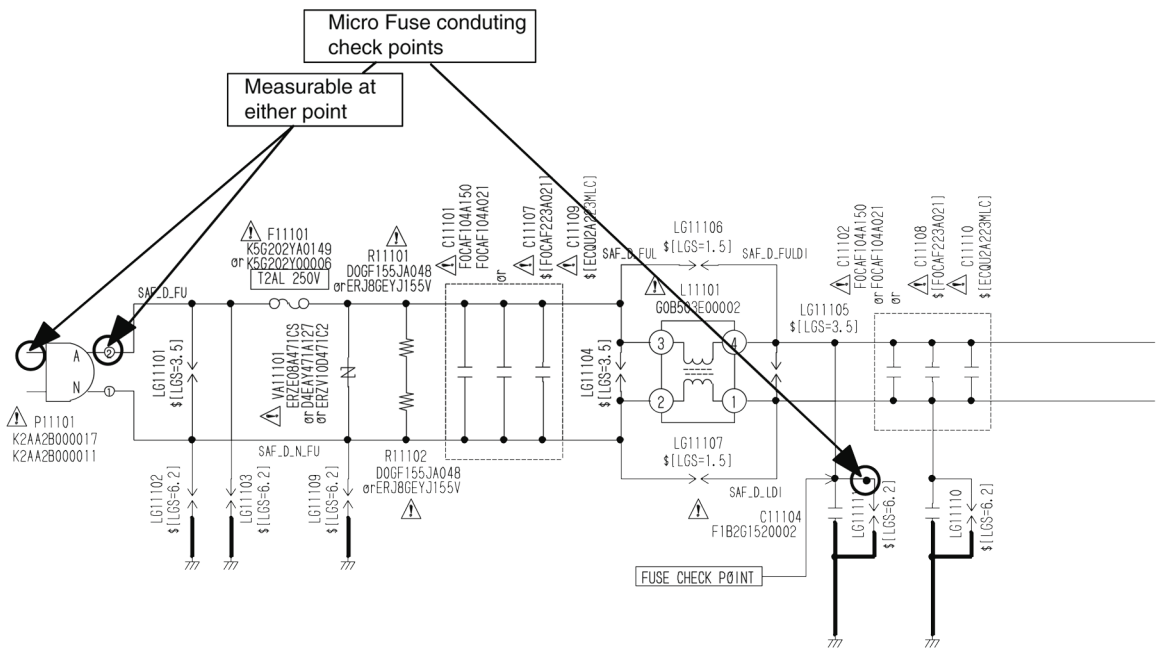

3.6. Operation check when a USB device is connected

You can check the operation status (normal or abnormal) of the USB connection part of this unit easily as shown below. Connect each device to the USB terminal on the front panel and check the operation status on the TV monitor.

Normal operation:

Automatically displayed when the USB connection is made to a digital camera, etc.

(Example below: When JPEG materials have been recorded)

(*Displayed items differ depending on the recorded contents.)



Abnormal operation (Example 1):

Warning is displayed automatically if overcurrent is detected when a USB device is connected.

(*When a USB device or this unit's USB terminal shorts out or the power supply type of USB device is connected)



Abnormal operation (Example 2):

When the terminal of USB device is damaged or open, there is no display on the TV monitor.

3.7. (HDD/BD Drive) Service Navigation

3.7.1. HDD/BD Drive Malfunction check (Simplified Method)

Perform simple quality judgement process of HDD/BD Drive according to the following operations.

1. Execute Service Mode
 - a. Turn the power off.
 - b. Press the [5] [9] and [R] button simultaneously for five seconds, then [70 RET] is displayed on FL.
 - c. Press the [▶] button to select until [80 SRV] is displayed on FL.
 - d. Press the [OK] button.
 - e. It is displayed on FL as [HELLO → SERV]:It is shown to have entered the service mode.
2. Press [3] [8] of remote controller keys in service mode.
3. Judge the quality on FL display.

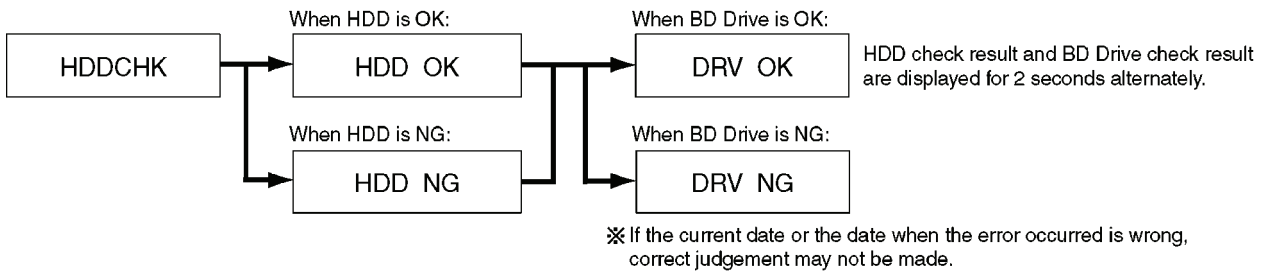

3.7.2. BD Drive Operation check flow

Perform quality judgement process of BD Drive according to the following operation.

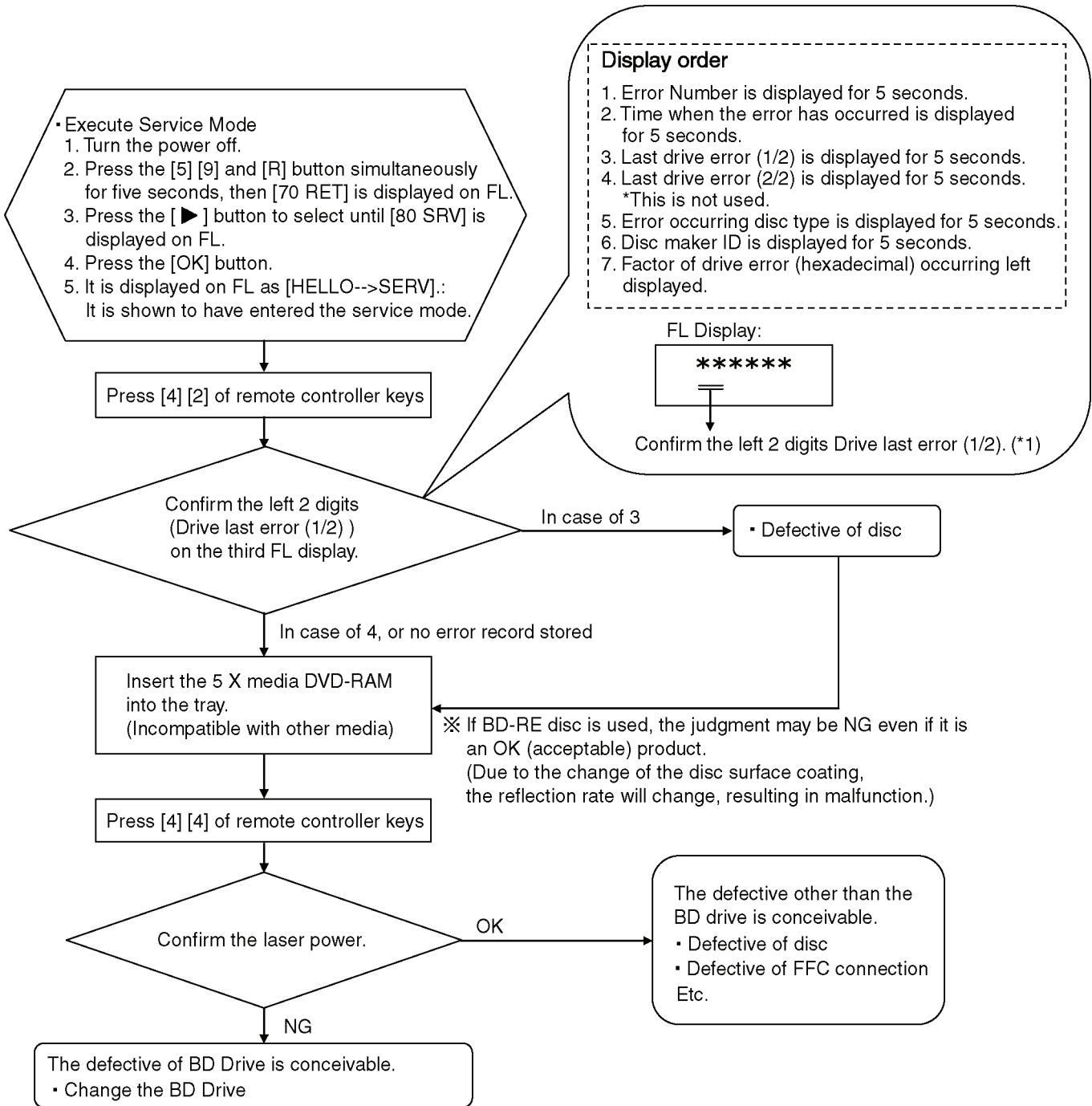

*1: The drive supports the following error sense keys:

Contents	Sense key	Description
NO SENSE	00	Successful completion.
RECOVERED ERROR	01	Successful completion through recovery.
NOT READY	02	The drive is unable to access the disc.
MEDIUM ERROR	03	An error caused by medium error has occurred.
HARDWARE ERROR	04	An error caused by the drive hardware has occurred.
ILLEGAL REQUEST	05	The CDB or parameter is illegal.
UNIT ATTENTION	06	The drive is alerting the host to some event.
DATA PROTECTED	07	The disc is read-protected or write-protected.
ABORTED COMMAND	08	The drive has aborted an I/O process or command execution due to a reason not relevant to any other sense key, for example, a protocol violation on the interface.

3.8. Wi-Fi Module (Internal) Malfunction Check (Simplified Method) (BWT760GN Only)

3.8.1. Procedure of the Module (Internal) Malfunction Check

3.8.1.1. Method of Wireless LAN Setting

1. Press [FUNCTION MENU].
2. Select "Basic Settings" in "Setup", then press [OK].
3. Select "Network Settings" in "Network", then press [OK].
4. Select "Wireless" in "LAN Connection Mode".
5. Press [OK]. The following "Wireless Setting screen (example)" is displayed.

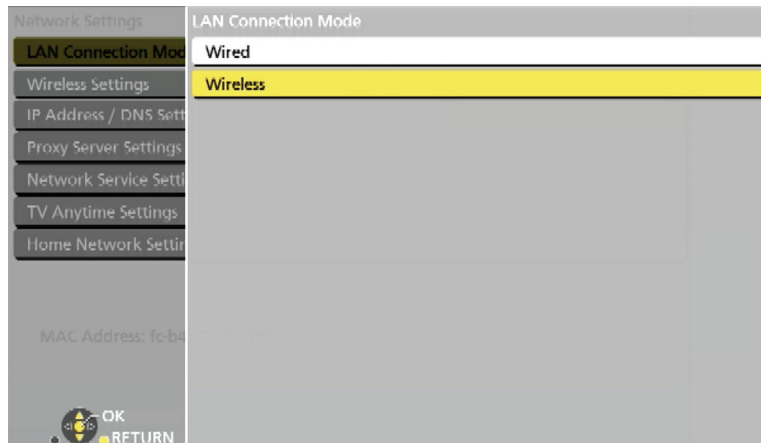

3.8.1.2. Method of displaying Wireless LAN Module Version

1. Press [FUNCTION MENU].
2. Select "Basic Settings" in "Setup", then press [OK].
3. Select "System Information" in "Others".
4. Press [OK]. The following "System Information screen (example)" is displayed.

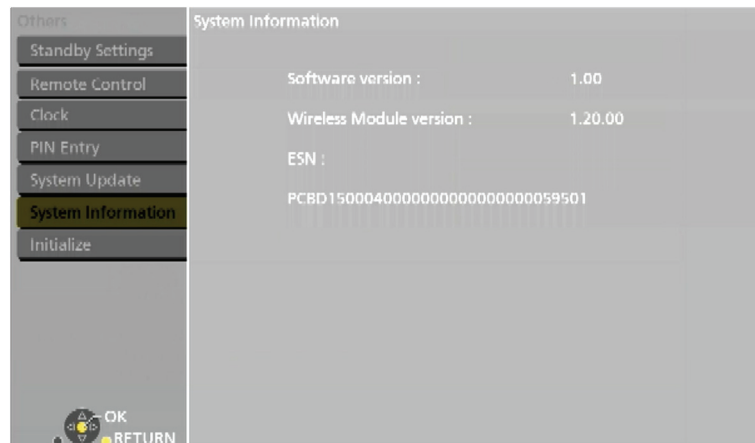

3.8.1.3. Confirm method of Wireless LAN Module invalidity/effective (BWT760GN Only)

1. Press [FUNCTION MENU].
2. Select "Basic Settings" in "Setup", then press [OK].
3. Select "Display" and press [OK].
4. Press [STATUS], over than 5 seconds. The following "Display screen (example)" is displayed.

In case of Wireless LAN Module effective.

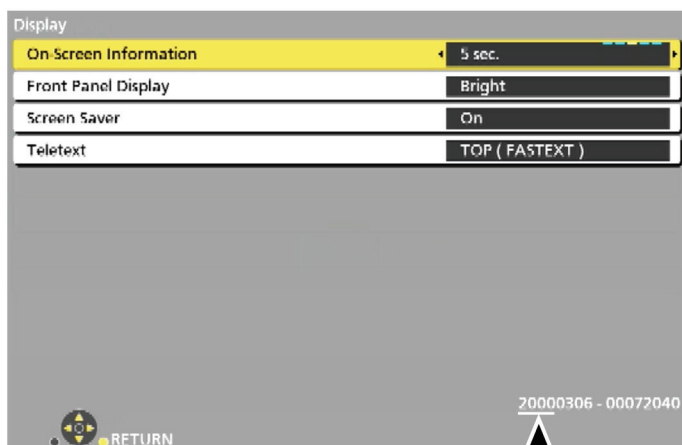

Wireless Module Version
(2000)

In case of Wireless LAN Module invalid.

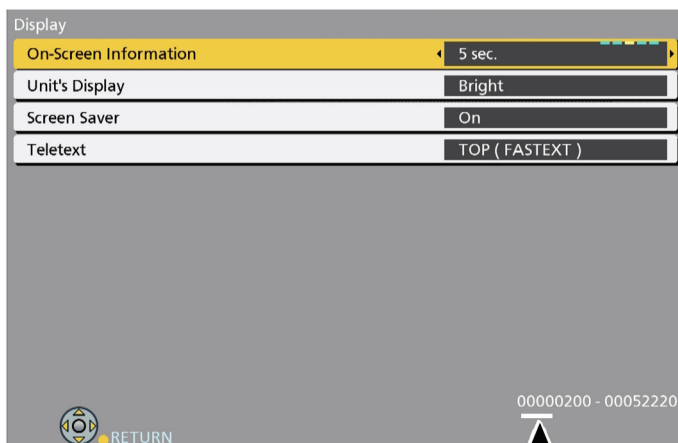

Wireless Module Version
(0000)

5. In case of Wireless LAN Module effective, Wireless LAN Module or Wireless LAN Module connection cable may be the source of problem.
6. Please finally check the operation of the fact.

3.9. Check with Tuner Service Mode

Inspect the inside components using the application for inspections by service personnel.

Main functions

N0	Function Name	Contents
01	Hard Test	Perform Access Test for each hard device and display the result.
02	User Setting Information Backup	Backup/ Restore User Setting Item (The Initial Setting) to the USB.
03	Time xxxxxxxx Count yyyyyyy	Length of Power ON time/ Count of power ON time

1. Execute Tuner Service Mode

- Turn the power on to receive digital broadcasting (HD broadcasting).
- Press the [5] [9] and [R] button simultaneously for five seconds, then [70 RET] is displayed on FL.
- Press the [▶] button to select until [82 TSR] is displayed on FL.
- Press the [OK] button.
- It is shown to have entered the tuner service mode.
- The command is transmitted by attached remote control.

2. Finishing Service Mode

Method 1: After turning the unit "OFF", pull out the AC cord.

Method 2: Repeat turning ON and OFF twice: P-OFF → P-ON → P-OFF → P-ON.

SRV-T00L	
Device TEST	
Backup Data to USB:	Restore Data from USB:
	Time 00000:00 Count 0000000

3.9.1. Hard Test (Device Test)

Perform Access Test for each hard device and display the result.

SRV-T00L	
Device TEST	
Backup Data to USB:	Restore Data from USB:
	Time 00000:00 Count 0000000

+-----+	
	-- Hard Test Result --
+-----+	
	<1> EEPROM [READ] (Result)
+-----+	
	<2> EEPROM [WRITE] (Result)
+-----+	
	<3> TUNER 1 (Result)
+-----+	
	<4> TUNER 2 (Result)
+-----+	
	<5> LAN (Result)
+-----+	
	<6> ----
+-----+	
	<7> ----
+-----+	
	<8> ----
+-----+	
	<9> ----
+-----+	

<Function>

- <1> : EEPROM [READ] : Read Test (Main P.C.B.:IC9501)
- <2> : EEPROM [WRITE] : Write Test (Main P.C.B.:IC9501)
- <3> : TUNER 1(DVB-T Tuner):I2C_Bus Check
- <4> : TUNER 2(DVB-T Tuner):I2C_Bus Check
- <5> : LAN:Register Access Test (Digital P.C.B. : IC59001)
- <6> : (None)
- <7> : (None)
- <8> : (None)
- <9> : (None)

<Display>

- <1> : EEPROM [READ] OK : Normality
 NG : EEPROM Read Error
- <2> : EEPROM [WRITE] OK : Normality
 NG : EEPROM Write Error
- <3> : TUNER 1 OK : Normality
 NG : TUNER (DVB-T Tuner) I2C_Bus. Error
- <4> : TUNER 2 OK : Normality
 NG : TUNER (DVB-T Tuner) I2C_Bus. Error
- <5> : LAN OK : Normality
 NG : LAN Register Access Error

Note:

Hard test result does not guarantee that problems do not exist even if the result is OK.
The result is used as reference when any trouble occurs.

3.9.2. Use times and number of times of Power ON/OFF

Display accumulated time of Power ON and display number of times of Power ON/OFF.

SRV-TOOL	
Device TEST	
Backup Data to USB:	Restore Data from USB:
Time 00000:00(*1)Count 0000000(*2)	

*1 : Display accumulated time of Power ON

Display on a 15-minute basis. Example: 00123:15 → 123 hour 15 minute

*2 : Display number of times of Power ON/OFF

Example: 0000123 →123

3.9.3. User Setting Information Backup

Purpose

After the recorder is repaired, the restored setting information is not default, but the information before repaired.

Operation summary

Before starting repair, import data on memory of the unit to export the data to USB on Tuner Service Mode display.

After the repair is finished, import the data on USB to export the data to the memory on the unit by operating on Tuner Service.

Mode display again.

• Data to be backed up

- Each setting item that a user can set at "SET UP" (*1) (START → FUNCTION → Setup-Basic Settings-Others).

The following data cannot be backed up.

- Program chart data
- Dedicated areas for Internet site service providers (unique information for each company), broadcast mail, two-way communication list, board, or favorite page
- Status saving systems (last channel except for VHF, UHF, drive selection status, etc.)

Note:

Of user setting information, only items selected and set on the initial Setup display can be backed up and restored.

*1: Of user setting information, except items selected and set on the initial Setup display.

Operation procedure

Preparation:

Prepare a USB to export data stored in this unit.

Create the following directory on the USB.

¥ EEPBAKUP

Boot:

1. On Tuner Service Mode display
2. There are many port models of USB, you need to make sure other USB ports don't connect USB memory and USB-HDD.
3. Insert USB memory for writing.
4. Using Remote Controller, move the cursor to useris setting information backup display position (Refer to below) on Tuner Service Mode display.
5. Press [OK].
After "Try → OK" is displayed, the data is exported to USB.
(Refer to below)

SRV-TOOL	
Device TEST	
Backup Data to USB : OK	Restore Data from USB:
Time 00000:00 Count 0000000	

When OK(***) is displayed, the data is successfully exported.

Note:

If the backup file already exists in the USB, the data is overwritten and "OK" is displayed.

6. Remove the USB from the unit.
7. Turn the unit OFF to finish Tuner Service Mode.

Restoring the back up data to the unit

1. Turn the unit ON.
Perform the following: Function MENU - Setup-Basic Settings-Others-Initialize-Shipping Condition.
2. Start Tuner Service Mode.
3. There are many port models of USB, you need to make sure other USB ports don't connect USB memory and USB-HDD.
4. Insert the USB in save data to the unit.
5. Using Remote Controller, move the cursor to user's setting information backup display position (Refer to below) on Tuner Service Mode display.

SRV-TOOL	
Device TEST	
Backup Data to USB: OK	Restore Data from USB:OK
	Time 00000:00 Count 0000000

6. Press [OK].
After "Try → OK" is displayed, the data is restored to USB.
(Refer to below)

SRV-TOOL	
Device TEST	
Backup Data to USB: OK	Restore Data from USB
	Time 00000:00 Count 0000000

When OK(***) is displayed, the data is successfully exported.

7. Remove the USB from the unit.
8. Turn the unit OFF to finish Tuner Service Mode.

3.10. Description of the Self Diagnosis <Operation Method, Details>

3.10.1. How to check the diagnosis code

This device can display the device information with a 16 digit number on the screen (Diagnosis code) in order for us to promptly check the customer's device installation status when the customer contacts our customer service center.

3.10.1.1. Procedure of the diagnosis code check

Prerequisites:

1. The power is ON.
2. EE viewing screen (not recording or acting as a server).

Procedure:

1. Press and hold [5], [9] and [Red] button on the remote control simultaneously for 5 sec. to switch to "Nondisclosure mode 2".
2. Switch the menu with either the [POWER] button on the main unit or the [Right cursor] on the remote control to display "Diagnosis Code" (FL display 96 DIC).
3. Start the menu by either pressing the [OPEN/CLOSE] button on the main unit or the [OK] button on the remote control.

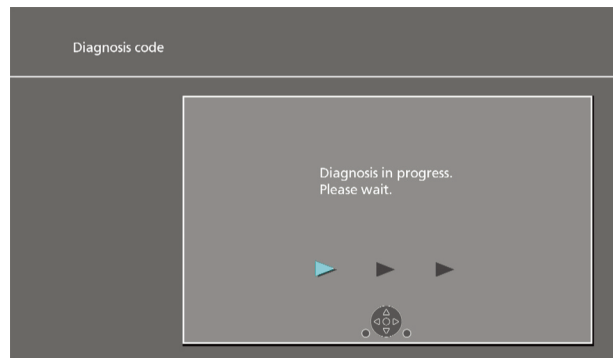

4. Press the OK button. The following "Diagnosis Code Screen (Example)" will be displayed.

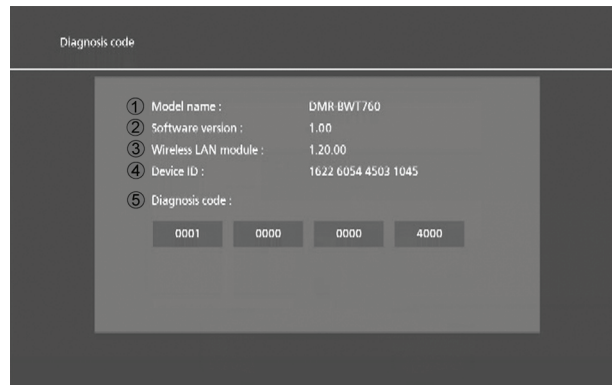

Item		Details
①	Model Name :	Display the model name.
②	Software version :	Display the software version.
③ For BWT760GN	Wireless LAN module :	Display the wireless LAN module version. (Wireless LAN incorporated model)
	Wireless LAN adapter :	Display the wireless LAN module version. (Wireless LAN external model)
	(No display)	Unsupported Wireless LAN model does not display.
④	Device ID :	Display the device ID.
⑤	Diagnosis code :	Display the diagnosis code.

3.10.1.2. Description of the diagnosis code screen

Each of the diagnosis code details:

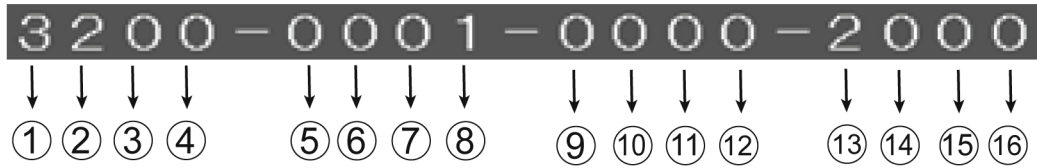

Digit	Diagnosis details	Digit	Diagnosis details
①	Drive system	⑨	HDMI terminal 2
②	HDD system	⑩	(Reserved)
③	(Reserved)	⑪	(Reserved)
④	USB-HDD diagnosis	⑫	(Reserved)
⑤	μ code/HDMI system	⑬	Abnormity History of Drive/HDD/FAN
⑥	TUNER system	⑭	(Reserved)
⑦	(Reserved)	⑮	(Reserved)
⑧	EEPROM/Ether	⑯	(Reserved)

[Specifications of Detailed Diagnostic Code]

1. Diagnosis of BD Drive

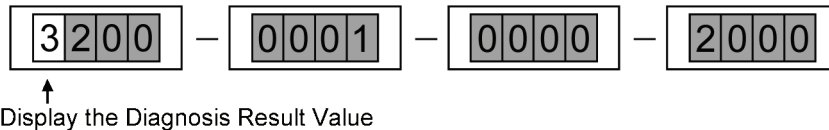

<Diagnosis Result Value>

0	There is no history of failure/ abnormality detected on the Drive. Please check other diagnosis items.
1	Unable to communicate with the Drive. Check to see if there is any problem with the connection between S-ATA cable or Drive power 6P cable and the voltage power supply. If there is no problem with the supply voltage or connection, there is a high possibility of Drive unit defect.
2	There is an error that can be determined as a failure in the Drive.
3	There is an error that is caused by disk error or disk operation. If this error occurs only in specific disk that you are using, check to see if the same malfunction occurs by changing the media to a disk of different manufacturer or different type. Check by unplugging and plugging back the FFC wire or S-ATA cable of Drive connection. Replace the wire for improvement. If the turntable is dirty, malfunction may originate from slipping phenomenon, etc. Please perform cleaning. If the disk cannot be read/written properly after cleaning, replacing the Drive may be necessary.
8	Unable to execute the Diagnosis Code Function normally. There is a possibility of malfunction in the digital P.C.B. side.
9	There is an error that can be determined as unsupported Drive. Replacing the Drive unit is necessary.
Other	The Input Code is not correct. Please check the Diagnosis Code again.

2. HDD Diagnosis

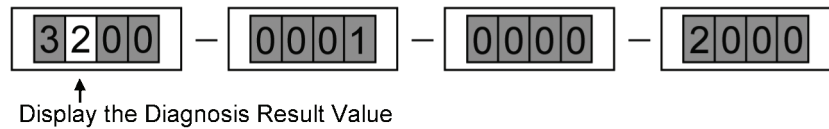

<Diagnosis Result Value>

0	No abnormality was detected from HDD inspection. Please check other diagnosis items.
1	Unable to communicate with the HDD. Check to see if there is any problem with the connection between each HDD connector and the voltage power supply. If there is no problem with the supply voltage or connection, there is a high possibility of HDD unit defect.
2	An abnormality that can be determined as HDD failure was detected. Replace the HDD unit.
8	Unable to execute the Diagnosis Code Function normally. There is a possibility of malfunction in the digital P.C.B. side.
Other	The Input Code is not correct. Please check the Diagnosis Code again.

3. USB-HDD Diagnosis

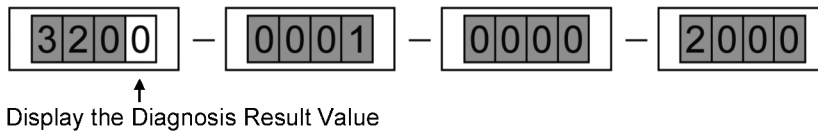

<Diagnosis Result Value>

0	No abnormality was detected from USB-HDD inspection. Please check other diagnosis items.
1	No USB-HDD is connected or some other device is connected. Check to see if there is any problem with the USB cable connection or the voltage power supply. If there is no problem with the supply voltage or connection, there is a high possibility of USB-HDD unit defect.
2	An abnormality that can be determined as USB-HDD failure was detected. Replace the USB-HDD unit.
6	If multiple USB-HDD units are connected.
7	If an unsupported USB-HDD is connected.
8	Unable to execute the Diagnosis Code Function normally. There is a possibility of malfunction in the digital P.C.B. side.

4. Digital/Tuner Main P.C.B. System Diagnosis

(1) IC communication in the digital P.C.B. (CPU and Flash/DDR/HDMI, etc.)

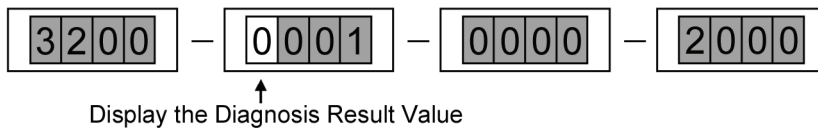

<Diagnosis Result Value>

0	No abnormality was detected in the digital P.C.B..
1	If there is a communication failure between CPU and FLASH/DDR, there is a high possibility of digital P.C.B. circuit (such as foil cutting) or parts failure.
2	If there is a communication failure between CPU and HDMI-LSI, there is a high possibility of digital P.C.B. circuit (such as foil cutting) or parts failure.
3	There is a communication failure between CPU and FLASH/DDR, and between CPU and HDMI-LSI. Take measures for "1" and "2".
4	There is an abnormality in HDMI-CEC circuit operation (High/Low Output). There is a high possibility of digital P.C.B. circuit failure (such as foil cutting) or parts failure.
5	There is a communication failure between CPU and FLASH/DDR, abnormality in HDMI-CEC circuit operation (High/Low Output). Take measures for "1" and "4".
6	There is a communication failure between CPU and HDMI-LSI, abnormality in HDMI-CEC circuit operation (High/Low Output). Take measures for "2" and "4".
7	There is a communication failure between CPU and FLASH/DDR and between CPU and HDMI-LSI, abnormality in HDMI-CEC circuit operation (High/Low Output). Take measures for "3" and "4".
Other	The Input Code is not correct. Please check the Diagnosis Code again.

(2) IC Communication of TUNER System

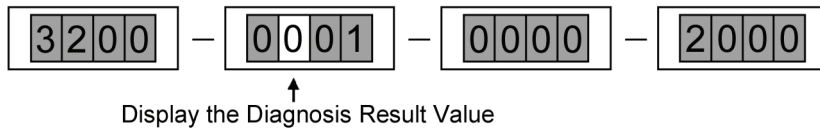

<Diagnosis Result Value>

0	No abnormality was detected in communication between the Digital Tuner and IC.
1	A communication abnormality occurred between the Digital Tuner (OFDM/Digital Modulation IC) and IC. There is a high possibility of Digital Tuner (OFDM/Digital Modulation IC) defect, or a communication failure between ICs.
2	A communication abnormality occurred between the Digital Tuner (LNB/Digital Modulation IC) and IC. There is a high possibility of Digital Tuner (LNB/Digital Modulation IC) defect, or a communication failure between ICs.
3	A communication abnormality occurred between the Digital Tuner (OFDM/Digital Modulation IC) and IC, Digital Tuner (LNB/Digital Tuner Modulation IC) and IC. There is a high possibility of Digital Tuner (OFDM/Digital Modulation IC) defect, Digital Tuner (LNB/Digital Modulation IC) defect, or a communication failure between ICs.
Other	The Input Code is not correct. Please check the Diagnosis Code again.

(3) Main P.C.B. IC communication (e.g. B-CAS/EEPROM)

Digital P.C.B. IC communication (e.g. Ether)

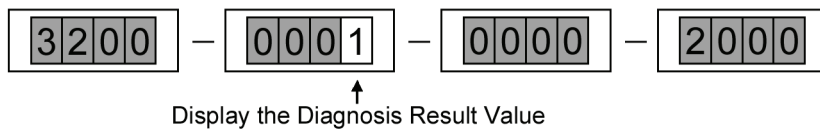

<Diagnosis Result Value>

0	No abnormality was detected.
2	An abnormality was detected in communication between the EEPROM of main P.C.B. and IC. Check the digital P.C.B. and main P.C.B. connection connector. If there is no problem, malfunction in the main P.C.B. is suspected.
4	Since a communication failure occurred between CPU and ETHER-LSI as well, there is a high possibility of digital P.C.B. circuit (such as foil cutting) or parts failure. Replace the Digital P.C.B..
6	A communication failure occurred between EEPROM of main P.C.B. and CPU, CPU and ETHER-LSI. Take measures for "2" and "4".
Other	The Input Code is not correct. Please check the Diagnosis Code again.

5. HDMI (SUB) Diagnosis

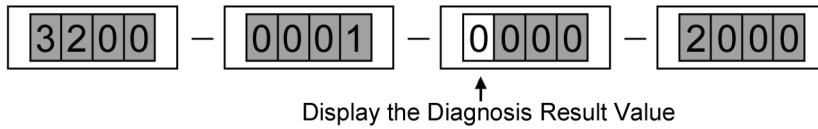

<Diagnosis Result Value>

0	No abnormality was detected in communication between the HDMI and IC.
2	An abnormality was detected in communication between the HDMI and IC. Please check the HDMI terminal connection and replace the HDMI terminal if no problem is found.
Other	The Input Code is not correct. Please check the Diagnosis Code again.

6. Failure History Analysis

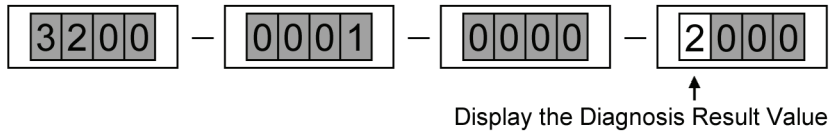

<Diagnosis Result Value>

0	There is no information for failure history.
1	If there is malfunction in Drive diagnosis items, there is a possibility that the Drive itself fails. ※Prioritize the Drive diagnosis results. In addition, if there is no malfunction in Drive diagnosis items, there is a possibility that the cause of malfunction is in the digital P.C.B..
2	If there is malfunction in HDD diagnosis items, there is a possibility that the HDD itself fails. ※Prioritize the HDD diagnosis results. In addition, if there is no malfunction in HDD diagnosis items, there is a possibility that the cause of malfunction is in the digital P.C.B..
3	There are malfunctions in Drive diagnosis items and HDD diagnosis items. Take measures for "1" and "2".
4	The fan motor may fail. Check for any snapped wire in fan motor, connector, and lead wire.
5	There is malfunction in Drive diagnosis items and the fan motor may fail. Take measures for "1" and "4".
6	There is malfunction in HDD diagnosis items and the fan motor may fail. Take measures for "2" and "4".
7	There are malfunctions in HDD diagnosis items, Drive diagnosis items and the fan motor may fail. Take measures for "3" and "4".
Other	The Input Code is not correct. Please check the Diagnosis Code again.

4 Specifications

Power supply: AC220-240V 50Hz
Power consumption: Approx. 25W (BWT460GN)
 Approx. 29W (BWT760GN)
Power consumption in standby mode: Approx. 0.2W
 Quick Start=Off, RF OUT (Aerial Signal)=Off
Operating temperature: 5°C-40°C
Operating humidity range: 10% - 80%RH (no condensation)

Television system
 Tuner System: DVB-T
 Channel Coverage: Australia New Zealand
 VHF:6~12
 UHF:27~69 UHF:21~69

Analog Video input (pinjack): 1 pc
 1Vp-p (75Ω)

Analog Audio L/R input (pinjack): 1 pc
 Full scale: 2.0 Vrms at 1kHz (>10kΩ)

Digital Audio Out (coaxial): 1pc
HDMI OUT (19pin type A): 1pc
Internal HDD Capacity: 500GB (BWT460GN)
 1TB (BWT760GN)

USB Port (Type A): USB2.0
 2 pc

SD Card Slot:(BWT760GN) 1pc
LAN (Ethernet) Port: 1pc
 10 BASE-T/100BASE-TX

Wireless LAN:(BWT760GN)
 Antenna: Tx2 , Rx2
 Standard Compliance: IEEE802.11a/b/g/n
 Transmission system: OFDM system, DSSS system
 Frequency Range: 2.4GHz /5GHz band
 Transfer rate (standard): IEEE802.11n : Max.300Mbps
 IEEE802.11g : Max.54Mbps
 IEEE802.11a : Max.54Mbps
 IEEE802.11b : Max.11Mbps
 * Transfer rates are theoretical values; however, actual communication rate will vary according to communication environment or connected equipment.
 Access Mode: Infrastructure mode
 Security: WPA™/WPA2™ (Encryption type: TKIP/AES. Authentication type:PSK)
 WEP(64bit / 128bit)

Recording System
 BD-RE (SL/DL): Blu-ray Disc Rewritable format
 BD-R (SL/DL): Blu-ray Disc Recordable format
 DVD-RAM: DVD Video Recording format
 DVD-R (SL/DL): DVD-Video format, AVCHD format
 DVD-RW: DVD-Video format
 +R (SL/DL), +RW

Recording time

Approx.

Recording Mode	HDD (500GB) (BWT460GN)	HDD (1TB) (BWT760GN)	BD-RE (SL, 25GB)	BD-RE (DL, 50GB)	BD-R (SL, 25GB)	BD-R (DL, 50GB)
DR *1 estimated bit rate						
For Australia (HD : 15Mbps) (SD : 8Mbps)	69 hours 131 hours	140 hours 264 hours	3h.20min. 6h.30min.	6h.40min. 13 hours	3h.20min. 6h.30min.	6h.40min. 13 hours
For New Zealand (HD : 14Mbps) (SD : 5Mbps)	75 hours 211 hours	151 hours 423 hours	3h.30min. 10h.15min.	7h.30min. 21 h.	3h.30min. 10h.15min.	7h.30min. 21 h.
HG	78 hours	157 hours	4 hours	8 hours	4 hours	8 hours
HX	117 hours	235 hours	6 hours	12 hours	6 hours	12 hours
HE	176 hours	353 hours	9 hours	18 hours	9 hours	18 hours
HL	235 hours	472 hours	12 hours	24 hours	12 hours	24 hours
HM	341 hours	684 hours	17h.30min.	35 hours	17h.30min.	35 hours
XP	107 hours	215 hours	5h.15min.	10h.30min.	5h.15min.	10h.30min.
SP	215 hours	431 hours	10h.30min.	21 hours	10h.30min.	21 hours
LP	430 hours	862 hours	21 hours	42 hours	21 hours	42 hours
EP	860 hours	1724 hours	42 hours	84 hours	42 hours	84 hours

Approx.

Recording Mode	DVD-RAM		DVD-R DVD-RW (4.7GB)	DVD-R DL (8.5GB)	+R +RW (4.7GB)	+R DL (8.5GB)
	4.7GB	9.4GB (Double Sided)				
DR *1, HG, HX, HE, HL, HM						
XP	1 hour	2 hours	1 hour	1h.45min.	1 hour	1h.45min.
SP	2 hours	4 hours	2 hours	3h.35min.	2 hours	3h.35min.
LP	4 hours	8 hours	4 hours	7h.10min.	4 hours	7h.10min.
EP	8 hours	16 hours	8 hours	14h.20min.	8 hours	14h.20min.

*1. Recording time of DR mode may vary depending on the bit rate of broadcasting.

LASER specification

Class 1 LASER Product
 Wave length: 783 nm(CDs) 661 nm(DVDs)
 405 nm(BDs)
 Laser power: No hazardous radiation is emitted with the safety protection
Region Code: DVD: #4
 BD: Region B

Playable discs

BD-Video: (Blu-ray 3D, BD-LIVE)
 BD-ROM Version 2.4
 DVD-VIDEO: DVD-Video format (Audio CD)
 CD-DA: Based on Ver.2.1, other files(*2)
 BD-RE: Based on Ver.2.1, other files(*2)
 BD-RE DL: Based on Ver.1.3 and LTH type Ver.1.3, other files(*2)
 BD-R: Based on Ver.1.3, other files(*2)
 BD-R DL: Based on Ver.1.3, other files(*2)
 DVD-RAM: DVD-Video Recording format, AVCHD format
 DVD-R: DVD-Video format(*1), AVCHD format(*1), other files(*3)
 DVD-R DL: DVD-Video format(*1), AVCHD format(*1), other files(*3)
 DVD-RW: DVD-Video format(*1), DVD Video Recording format, AVCHD format(*1)
 +R: DVD-Video format(*1), AVCHD format(*1), other files(*3)
 +R DL: DVD-Video format(*1), AVCHD format(*1), other files(*3)
 +RW: DVD-Video format(*1), AVCHD format(*1)
 CD-R: CD-DA, other files(*4)
 CD-RW: CD-DA, other files(*4)

*1: Finalizing is necessary.

*2: BD disc that is including other file needs to be based on UDF format.

*3: DVD disc that is including other file needs to be based on UDF or ISO9660 format.

*4: CD disc that is including other file need to be based on ISO9660 format.

SD card (BWT760GN):

SD Memory Card (includes SDHC, SDXC card)

Format:	SD Card	only FAT12, FAT16
	SDHC Card	only FAT32
	SDXC Card	only exFAT

USB device

USB2.0 High Speed

USB mass storage device class is supported.

Format: FAT12, FAT16, FAT32, NTFS

Broadcast Recordings

Numbers of titles that can be recorded

	Maximum titles (BWT460GN)	Maximum titles (BWT760GN)
HDD	1000	3000
BD-RE, BD-R	200	200
DVD-RAW, DVD-R, DVD-RW	99	99
+R, +RW	49	49

*Maximum numbers of titles is including recordings of HD CAM-CORDER.

HD CAMCORDER Recordings

MPEG-4 AVC/H.264 (based on AVCHD)

Numbers of titles that can be recorded

	Maximum titles (BWT460GN)	Maximum titles (BWT760GN)
HDD	1000	3000
BD-RE, BD-R	200	200

*Maximum numbers of titles is including recordings of Broadcast.

Photo files

JPEG based on DCF [Design rule for Camera File system]

MPO based on MPF [Multi Picture Format]

Pixels: 34 x 34 ~ 8192 x 8192

Sub Sampling: 4:2:2, 4:2:0

Motion JPEG not supported.

Maximum numbers of contents

	folders	files
HDD	-	20000
BD-RE, DVD-R, DVD-RAM, CD-R, CD-RW, USB device, SD card (BWT760GN)	500	10000

Video files Audio files (BWT460GN)

Support codecs of Video: Xvid, MKV, MP4, MPEG2 (TS/PS) *1

Support codecs of Audio: MP3, AAC (M4A) *1

*1: Supported codecs depend on media type.

Numbers of contents that can be copied to internal HDD

	Maximum numbers of folders and files
Video contents	20000
Audio contents	20000

Video files Audio files (BWT760GN)

Support codecs of Video: MKV, MP4 (4K/24p, 25p and 30p*2), MPEG2 (TS/PS) *1

Support codecs of Audio: MP3, WAV, FLAC, AAC (M4A), WMA, ALAC.DSD *1

*1: Supported codecs depend on media type.

*2: bit rate up to 100Mbps/resolution up to 3840 x 2160 25p/30p, 4096 x 2160 24p

Numbers of contents that can be copied to internal HDD

	Maximum numbers of folders and files
Video contents	20000
Audio contents	20000

HDMI

This unit supports "HDAVI Control 5" function.

Dimensions (BWT460GN):

430mm(W) x 41.5mm(H) x 179mm(D) (excluding the projecting parts)

430mm(W) x 41.5mm(H) x 193mm(D) (including the projecting parts)

Dimensions (BWT760GN):

430mm(W) x 42.5mm(H) x 179mm(D) (excluding the projecting parts)

430mm(W) x 42.5mm(H) x 193mm(D) (including the projecting parts)

Mass:

Approx. 1.8kg (BWT460GN)

Approx. 2.1kg (BWT760GN)

Recordable discs:

BD-RE(SL/DL): 1-2X SPEED (Ver.2.1)

BD-R(SL/DL): 1-2X SPEED (Ver.1.1)

1-4X SPEED (Ver.1.2)

1-6X SPEED (Ver.1.3)

1-2X SPEED LTH type (Ver.1.2)

1-6X SPEED LTH type (Ver.1.3)

DVD-RAM:

2X SPEED (Ver.2.0)

2-3X SPEED (Ver.2.1)

2-5X SPEED (Ver.2.2)

DVD-R(SL):

1X SPEED (Ver.2.0)

1-4X SPEED (Ver.2.0)

1-8X SPEED (Ver.2.0)

1-16X SPEED (Ver.2.1)

DVD-R(DL):

2-4X SPEED (Ver.3.0)

2-8X SPEED (Ver.3.0)

DVD-RW:

1X SPEED (Ver.1.1)

1-2X SPEED (Ver.1.1)

2-4X SPEED (Ver.1.2)

2-6X SPEED (Ver.1.2)

+R(SL):

2.4X SPEED (Ver.1.0)

2.4-4X SPEED (Ver.1.1)

2.4-8X SPEED (Ver.1.2)

2.4-16X SPEED (Ver.1.3)

+R(DL):

2.4X SPEED (Ver.1.0)

2.4-8X SPEED (Ver.1.1)

+RW:

2.4X SPEED (Ver.1.1)

2.4-4X SPEED (Ver.1.2)

Optical pick-up:

System with 2 lens, 3integration units

(405 nm wavelength for BDs, 661 nm wavelength for DVDs, 783 nm wavelength for CDs)

Solder:

This model uses lead free solder(PbF).

Note:

Specifications are subject to change without notice.

Useable capacity will be less.(SD Card)

5 Location of Controls and Components

Front

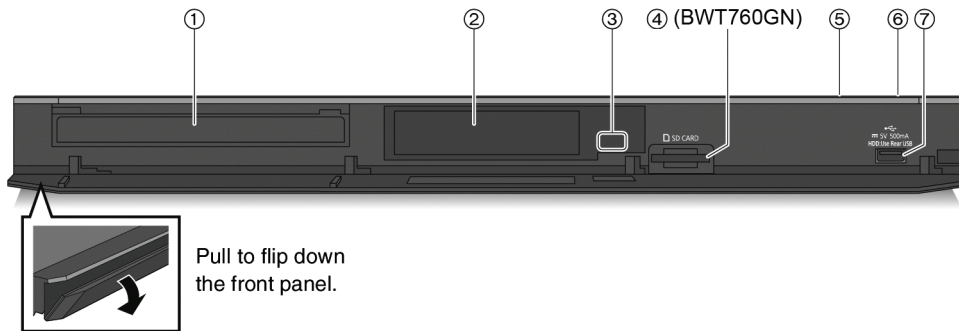

- ① Disc tray
- ② Display
- ③ Remote control signal sensor
 - Angle: Approx. 20° up and down, 30° left and right
 - Distance: Within approx. 7 m in front of the unit
- ④ SD card slot (BWT760GN)
 - When removing the SD card, press on the centre of the card and pull it straight out.
- ⑤ Open/close disc tray
- ⑥ **Standby/on switch (⏻/⏻)**
 - Press to switch the unit from on to standby mode or vice versa. In standby mode, the unit is still consuming a small amount of power.
- ⑦ USB port (⏻ DC 5 V 500 mA)

Inserting or removing media

■ Disc

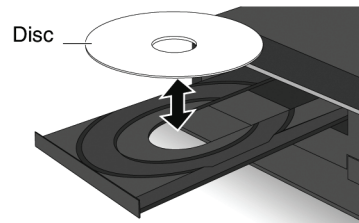

■ SD Card(BWT760GN)/USB device

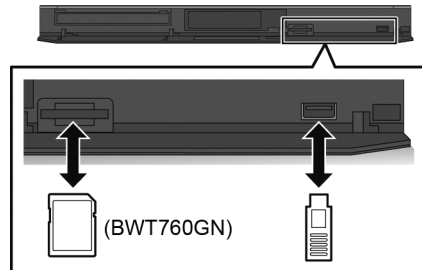

- While writing to/reading from the media, do not switch the unit to standby mode or remove the media. Such action may result in loss of the media contents.
- When inserting the media, ensure that it is facing the right way up.
- The USB port on the front side does not support USB HDDs. Connect a USB HDD to the USB port on the rear side.

Display

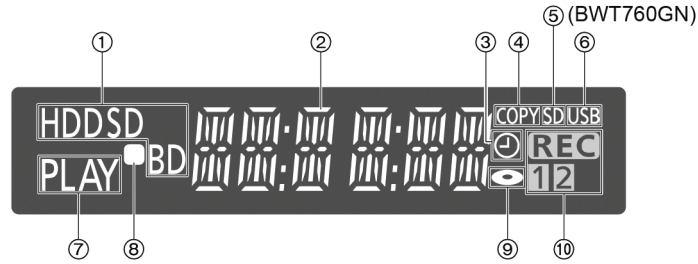

- | | |
|--|--|
| <ul style="list-style-type: none"> ① Drive (HDD, BD or SD) indicator ② Main display section indicator <ul style="list-style-type: none"> • Messages and other information are displayed. ③ Timer recording indicator <ul style="list-style-type: none"> • This indicator lights up when the timer recording standby or Keyword Recording standby is activated. ④ Copying indicator | <ul style="list-style-type: none"> ⑤ SD card slot indicator (BWT760GN) ⑥ USB port indicator ⑦ Playback indicator ⑧ Remote control signal indicator ⑨ Disc indicator ⑩ Recording indicator <ul style="list-style-type: none"> • “REC” lights up while recording is in progress. • “1” flashes when the first timer recording standby is activated or recording is paused, and lights up while recording is in progress. (In the same way as “1”, “2” lights up or flashes for the second recording.) |
|--|--|

Rear

(BWT760GN)

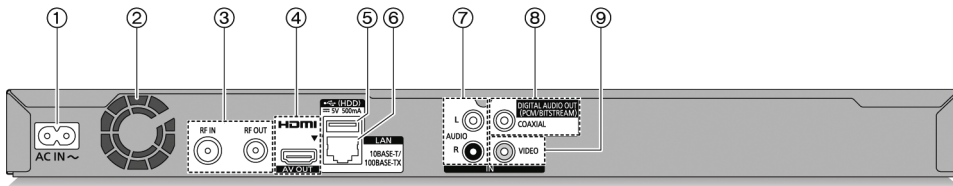

(BWT460GN)

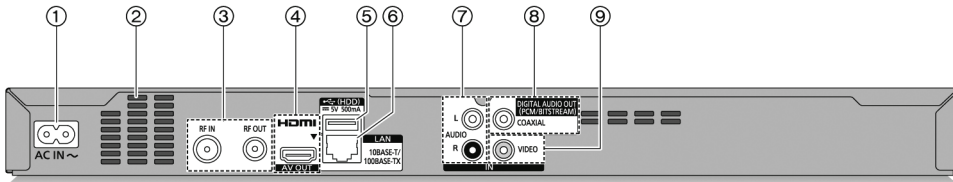

- | | |
|---|--|
| <ul style="list-style-type: none"> ① AC IN terminal (~) ② Cooling fan (BWT760GN)/
Ventilation hole (BWT460GN) ③ RF IN/OUT terminal ④ HDMI terminal ⑤ USB port (≡ DC 5 V 500 mA) | <ul style="list-style-type: none"> ⑥ LAN port ⑦ AUDIO IN terminal ⑧ COAXIAL terminal ⑨ VIDEO IN terminal <p><input type="checkbox"/> Class II equipment (The construction of the product is double-insulated.)</p> |
|---|--|

Control reference guide (Remote Control) (BWT460GN)

Instructions for operations are generally described using the remote control.

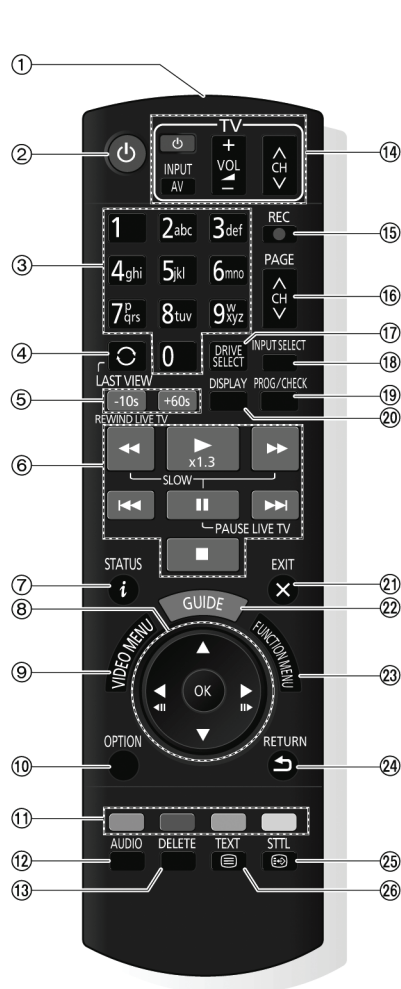

- ① Transmit the remote control signal
 - Point it at remote control signal sensor on this unit.
- ② Switch the unit from on to standby mode or vice versa
- ③ Select channels and title numbers, etc./Enter numbers or characters
- ④ Switch to the previously watched channel
- ⑤ Manual skip
 - 10s: Skip approx. 10 seconds backward
 - +60s: Skip approx. 1 minute forward
- ⑥ Basic operations for recording and play, REWIND LIVE TV/PAUSE LIVE TV
- ⑦ Show Information
- ⑧ Selection/OK, Frame-by-frame
- ⑨ Show Video Menu, Top Menu, Pop-up Menu
- ⑩ Show OPTION menu
- ⑪ Colour buttons (red, green, yellow, blue)
(Use in accordance with instruction on the screen.)
- ⑫ Select audio
- ⑬ To delete unwanted recorded titles, timer programmes, video, photo or music
- ⑭ TV operation buttons
- ⑮ Start recording
- ⑯ Channel select/Change pages in the Video Menu screen etc.
- ⑰ Select drive (HDD, Disc or USB)
- ⑱ Input select
- ⑲ Show the Timer recording screen
- ⑳ Show Playback Menu
- ㉑ Exit the menu screen
- ㉒ Show the TV Guide screen
- ㉓ Show the FUNCTION MENU screen
- ㉔ Return to previous screen
- ㉕ Show subtitles
- ㉖ Show Teletext

Control reference guide (Remote Control) (BWT760GN)

Instructions for operations are generally described using the remote control.

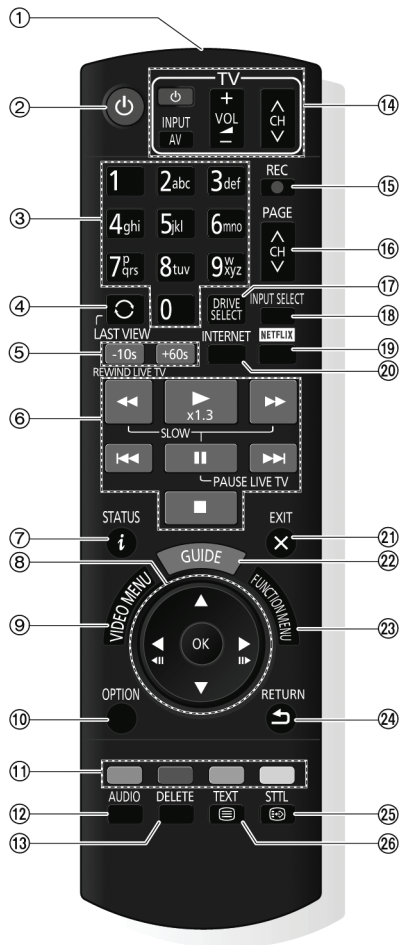

- ① Transmit the remote control signal
 - Point it at remote control signal sensor on this unit.
- ② Switch the unit from on to standby mode or vice versa
- ③ Select channels and title numbers, etc./Enter numbers or characters
- ④ Switch to the previously watched channel
- ⑤ Manual skip
 - 10s: Skip approx. 10 seconds backward
 - +60s: Skip approx. 1 minute forward
- ⑥ Basic operations for recording and play, REWIND LIVE TV/PAUSE LIVE TV
- ⑦ Show Information
- ⑧ Selection/OK, Frame-by-frame
- ⑨ Show Video Menu, Top Menu, Pop-up Menu
- ⑩ Show OPTION menu
- ⑪ Colour buttons (red, green, yellow, blue) (Use in accordance with instruction on the screen.)
- ⑫ Select audio
- ⑬ To delete unwanted recorded titles, timer programmes, video, photo or music
- ⑭ TV operation buttons
- ⑮ Start recording
- ⑯ Channel select/Change pages in the Video Menu screen etc.
- ⑰ Select drive (HDD, Disc, SD or USB)
- ⑱ Input select
- ⑲ Show NETFLIX screen
- ⑳ Show the Network Service screen
- ㉑ Exit the menu screen
- ㉒ Show the TV Guide screen
- ㉓ Show the FUNCTION MENU screen
- ㉔ Return to previous screen
- ㉕ Show subtitles
- ㉖ Show Teletext

6 Installation Instructions

6.1. Taking out the Disc from BD-Drive Unit when the Disc cannot be ejected by [OPEN/CLOSE] button

6.1.1. Forcible Disc Eject

6.1.1.1. When the power can be turned off.

1. Turn off the power, press and hold [OK], [B] and [Y] on the remote control at the same time for more than 5 seconds.
- "00 RET" is displayed on the unit's display.
2. Repeatedly press [▶] on the remote control or [POWER] on the unit until "06 FTO" is displayed on the unit's display.
3. Press [OK] on the remote control or [OPEN/CLOSE] on the unit.

6.1.1.2. When the power can not be turned off.

1. Press [POWER] key on the front panel for over 4 seconds to turn off the power forcibly, press and hold [OK], [B] and [Y] on the remote control at the same time for more than 5 seconds.
- "00 RET" is displayed on the unit's display.
2. Repeatedly press [▶] on the remote control or [POWER] on the unit until "06 FTO" is displayed on the unit's display.
3. Press [OK] on the remote control or [OPEN/CLOSE] on the unit.

6.1.2. When the Forcible Disc Eject can not be done.

1. Turn off the power and pull out AC cord.
2. Put deck so that bottom can be seen.
3. Slide SLIDE CAM by Paper Clip or minus screw driver (small) in the direction of arrow to eject tray slightly.

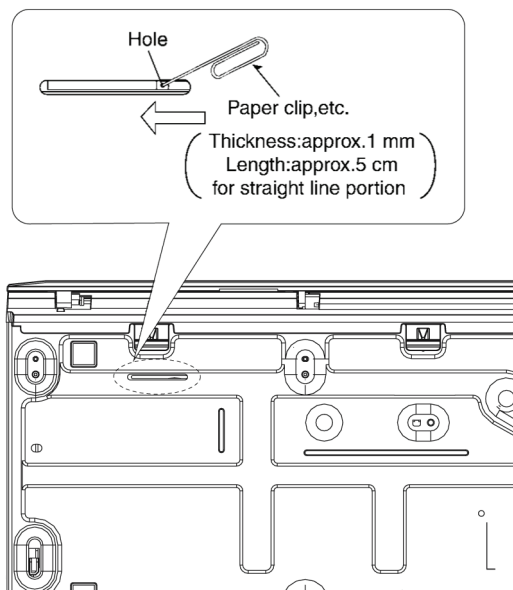

4. Put deck upward, and pick out Tray by finger.

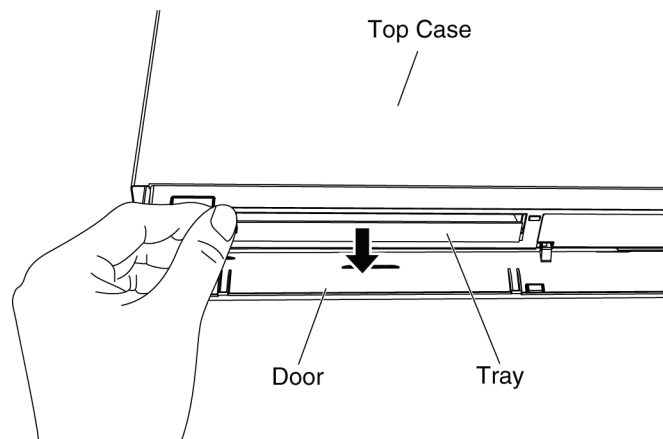

7 Service Mode

7.1. Self-Diagnosis and Special Mode Setting

7.1.1. Self-Diagnosis Functions

Self-Diagnosis Function provides information for errors to service personnel by "Self-Diagnosis Display" when any error has occurred.

U, H** and F** are stored in memory and held.**

You can check latest error code by transmitting [0] [1] of Remote Controller in Service Mode.

Automatic Display on FL will be cancelled when the power is turned off or AC input is turned off during self-diagnosis display is ON.

Error Code	Diagnosis Contents	Description	Monitor Display	Automatic FL display
U30	Remote control code error	Display appears when main unit and remote controller codes are not matched.	No display	<div style="border: 1px solid black; padding: 5px; text-align: center;">BD *</div> <p>"" is remote controller code of the main unit. Display for 5 seconds.</p>
U59	Abnormal inner temperature detected	Display appears when internal temperature of deck reaches limit temperature. The power is turned off forcibly. For 30 minutes after this, all key entries are disabled. (Fan motor operates at the highest speed for the first 5 minutes. For the remaining 25 minutes, fan motor is also stopped.) The event is saved in memory as well.	No display	<div style="border: 1px solid black; padding: 5px; text-align: center;">U59</div> <p>"U59" is displayed for 30 minutes.</p>
U61	The unit is carrying out its recovery process. (with no disc in the disc tray)	<ul style="list-style-type: none"> The unit detected an error while recording or playing with no disc in the disc tray. The unit is carrying out its recovery process. This process restores the unit to normal operation. The unit is not broken. Wait until the message disappears. 	No display	<div style="border: 1px solid black; padding: 5px; text-align: center;">U61</div>
U71	HDMI incompatible error (HDCP incompatible)	Display this error when the equipment (compatible with DVI such as TV, amplifier etc.) connected to the unit by HDMI is incompatible with HDCP. *HDCP=High-bandwidth Digital Content Protection	No display	<div style="border: 1px solid black; padding: 5px; text-align: center;">U71</div>
U72	HDMI connection error (Communication error)	This error is displayed when there are any communication problems with the unit and the equipments (TV, amplifier etc.) connected to the unit by HDMI. (or when there is a problem with the HDMI cable)	No display	<div style="border: 1px solid black; padding: 5px; text-align: center;">U72</div> <p>U72 display disappears when error has been solved by Power OFF/ON of connecting equipment or by inserting/removing of HDMI cable.</p>
U73	HDMI connection error (authentication error)	When authentication error occurs while the equipments (TV, amplifier etc.) are connected by HDMI. (or when there is a problem with the HDMI cable)	No display	<div style="border: 1px solid black; padding: 5px; text-align: center;">U73</div> <p>U73 display disappears when error has been solved by Power OFF/ON of connecting equipment or by inserting/removing of HDMI cable.</p>
U76	HDMI connection error	HDMI cannot be output because you are connected to a model that does not support copyright protection.	No display	<div style="border: 1px solid black; padding: 5px; text-align: center;">U76</div>
U77	Illegal disc error	Due to the current disc not having authorized copyright information, video output is not performed.	No display	<div style="border: 1px solid black; padding: 5px; text-align: center;">U77</div>

Error Code	Diagnosis Contents	Description	Monitor Display	Automatic FL display
U88	The unit is carrying out its recovery process. (with a disc in the disc tray)	• The unit detected an error while recording or playing with a disc in the disc tray. The unit is carrying out its recovery process. This process restores the unit to normal operation. The unit is not broken. Wait until the message disappears.	No display	U88
U99	Hang-up	Displayed when communication error has occurred between Main microprocessor and Timer microprocessor.	No display	U99 Displayed is left until the [POWER] key is pressed.
H19 02	Inoperative fan motor	When inoperative fan motor is detected after powered on, the power is turned off automatically. The event is saved in memory.	No display	No display
F00	No error information	Initial setting for error code in memory (Error code Initialization is possible with error code initialization and main unit initialization.)	No display	F00
F34	Initialization error when main microprocessor is started up for program recording	When initialization error is detected after starting up main microprocessor for program recording, the power is turned off automatically. The event is saved in memory.	No display	No display
F58	Drive hardware error	When Drive unit error is detected, the event is saved in memory.	No display	No display
F74	HDMI Device Key Communication error	HDMI connection could not be authenticated due to a transfer malfunction. Factor of HDMI Device key-road failure <ul style="list-style-type: none"> • When HDMI LSI is damaged. • When the bus line of I2C doesn't operate normally. • When device key information recorded is damaged. 	No display	F74
F75	HDMI Device Key Information error	HDMI connection could not be authenticated due to an internal data malfunction. Factor of HDMI Device key-road failure <ul style="list-style-type: none"> • When HDMI LSI is damaged. • When the bus line of I2C doesn't operate normally. • When device key information recorded is damaged. 	No display	F75
UNSUPPORT	Unsupported disc error	*An unsupported format disc was played, although the drive starts normally. *The data format is not supported, although the media type is supported. *Exceptionally in case of the disc is dirty.	"This disc is incompatible."	Displayed for 5 seconds. UNSUPPORT The character indication flows sideways.
NO READ	Disc read error	*A disc is flawed or dirty. *A poor quality failed to start. *The track information could not be read.	"Cannot read. Please check the disc."	NOREAD
HARD ERR	Drive error	The Drive detected a hard error.	"BD Drive error."	Display for 5 seconds. HARD ERR The character indication flows sideways.
SELF CHECK	Restoration operation	Since the power cord fell out during a power failure or operation, it is under restoration operation. *It will OK, if a display disappears automatically. If a display does not disappear, there is the possibility that defective Digital P.C.B. / BD Drive.	No display	SELF CHECK The character indication flows sideways.
PLEASE WAIT	Unit is in termination process	Unit is in termination process now. "BYE" is displayed and power will be turned off. In case "Quick Start" of setup menu is ON, it is displayed in restoration operation for AC off.	No display	PLEASE WAIT The character indication flows sideways.

Error Code	Diagnosis Contents	Description	Monitor Display	Automatic FL display			
UNFORM-AT	Unformatted disc error	You have inserted an unformatted BD-RE, BD-R, DVD-RAM or DVD-RW that is unformatted or recorded on other equipment.	<table border="1"> <tr> <td>Format</td> </tr> <tr> <td>This disc is not formatted properly. Format the disc in DISK MANAGEMENT?</td> </tr> </table>	Format	This disc is not formatted properly. Format the disc in DISK MANAGEMENT?	<table border="1"> <tr> <td>UNFOR MAT</td> </tr> </table> <p>The character indication flows sideways.</p>	UNFOR MAT
Format							
This disc is not formatted properly. Format the disc in DISK MANAGEMENT?							
UNFOR MAT							
IR ERR	IR communication error	[IR ERR] is displayed when communication between Timer microprocessor and IR microprocessor fails.	No display	<table border="1"> <tr> <td>IR ERR</td> </tr> </table>	IR ERR		
IR ERR							
No REC	Recording is impossible	[No REC] is displayed when recording is impossible due to the defect, dirt or wound of media.	No display	<table border="1"> <tr> <td>NoREC</td> </tr> </table>	NoREC		
NoREC							
HDD ERROR	[HDD ERR] is displayed when start up of HDD was failed. (Except error of setting of Power on Stand-by)	<p>a) When normal start up was failed.</p> <p>b) When start up at HDD boot was failed.</p> <p>c) When start up from state of P-OFF was failed.</p> <p>d) When start up from state of HDD SLEEP was failed.</p> <p>[HDD ERR] is displayed when above each start up of HDD was failed.</p> <p>*In case b), tray opens automatically and [HDDERR] is displayed until version up disc is inserted.</p>	No display	<table border="1"> <tr> <td>HDDERR</td> </tr> </table>	HDDERR		
HDDERR							
HDD NG	Power on Stand-by setting error	[HDD NG] is displayed when power on Stand-by setting of HDD is NG or when HDD which power on Stand-by is not set to is used. Please try to replace HDD with genuine HDD as service parts.	No display	<table border="1"> <tr> <td>HDD NG</td> </tr> </table>	HDD NG		
HDD NG							
NoERAS	Erase is impossible	You cannot delete items on this disc. The disc may be damaged. Use a new disc.	No display	<table border="1"> <tr> <td>NoERAS</td> </tr> </table>	NoERAS		
NoERAS							
NoWRIT	Writing is impossible	You cannot write to this disc. The disc may be damaged. Use a new disc.	No display	<table border="1"> <tr> <td>NoWRIT</td> </tr> </table>	NoWRIT		
NoWRIT							
PROG FULL	Timer programmes are full	There are already 32 timer programmes. Delete unnecessary timer programmes.	No display	<table border="1"> <tr> <td>PROG FULL</td> </tr> </table>	PROG FULL		
PROG FULL							

7.1.2. Special Modes Setting

* The command is transmitted by attached remote control.

Item		FL Display	Key Operation
Mode Name	Description		
Rating password	The audiovisual level setting password is initialized to "Level 8".	① 00 RET ② 03 VL ③ INIT	① While the unit is on, disc is not in tray, press and hold [OK], [B] and [Y] on the remote control at the same time for more than 5 seconds. -"00 RET" is displayed on the unit's display. ② Repeatedly press [▶] on the remote control or [POWER] on the unit until. "03 VL" is displayed on the unit's display. ③ Press [OK] on the remote control or [OPEN/CLOSE] on the unit.
Service Mode	Setting every kind of modes for servicing. *Details are described in "7.1.3. Service-Mode at a glance".	② 70 RET ③ 80 SRV ④ HELLO--SERV	① While the power is off, press and hold [5], [9] and [R] on the remote control at the same time for more than 5 seconds. -"70 RET" is displayed on the unit's display. ② Repeatedly press [▶] on the remote control or [POWER] on the unit until "80 SRV" is displayed on the unit's display. ③ Press [OK] on the remote control or [OPEN/CLOSE] on the unit.
BD-ROM history cleaning	< Persistent Storage > of BD-ROM standard is cleaned. Screen display: [The history has been cleared.] is displayed for five seconds.	① 50 RET ② 51 NOP ③ 52 BRE	① While the unit is on, disc is not in tray, press and hold [6], [7] and [Y] on the remote control at the same time for more than 5 seconds. -"50 RET" is displayed on the unit's display. ② Repeatedly press [▶] on the remote control or [POWER] on the unit until "51 NOP" is displayed on the unit's display. ③ Press and hold [STOP] on the remote control until "52 BRE" is displayed on the unit's display. ④ Press [OK] on the remote control or [OPEN/CLOSE] on the unit.
Forced disc eject	Removing a disc that cannot be ejected. The tray will open and unit will shift to P-off mode. While Demonstration Lock is being set, this Forced disc eject function is not accepted.	① 00 RET ② 06 FTO	① While the power is off, press and hold [OK], [B] and [Y] on the remote control at the same time for more than 5 seconds. -"00 RET" is displayed on the unit's display. ② Repeatedly press [▶] on the remote control or [POWER] on the unit until "06 FTO" is displayed on the unit's display. ③ Press [OK] on the remote control or [OPEN/CLOSE] on the unit.
Forced power-off	When the power button is not effective while power is ON, turn off the power forcibly. *When Timer REC is ON or EXT-LINK is ON, execute "Forced Power-off" after releasing Timer REC or EXT-LINK.	Display in P-off mode.	Press [POWER] key over than 10 seconds.

Item		FL Display	Key Operation
Mode Name	Description		
Demonstration lock/unlock	Ejection of the disc is prohibited. The lock setting is effective until unlocking the tray and not released by Main unit initialization of service mode.	*When lock the tray. ① 00 RET ② 04 PRG ③ 10 OCL ④ LOCK "LOCK" is displayed for 3 seconds.	① While the unit is on, disc is in tray, press and hold [OK], [B] and [Y] on the remote control at the same time for more than 5 seconds. - "00 RET" is displayed on the unit's display. ② Repeatedly press [▶] on the remote control or [POWER] on the unit until "04 PRG" is displayed on the unit's display. ③ Press and hold [STOP] on the remote control until "10 OCL" is displayed on the unit's display. ④ Press [OK] on the remote control or [OPEN/CLOSE] on the unit.
		*When unlock the tray. ① 00 RET ② 04 PRG ③ 10 OCL ④ UNLOCK "UNLOCK" is displayed for 3 seconds.	① While the unit is on, disc is in tray, press and hold [OK], [B] and [Y] on the remote control at the same time for more than 5 seconds. - "00 RET" is displayed on the unit's display. ② Repeatedly press [▶] on the remote control or [POWER] on the unit until "04 PRG" is displayed on the unit's display. ③ Press and hold [STOP] on the remote control until "10 OCL" is displayed on the unit's display. ④ Press [OK] on the remote control or [OPEN/CLOSE] on the unit.
		*When press [OPEN/CLOSE] key while the tray being locked. LOCK Display "LOCK" for 3 seconds.	Press [OPEN/CLOSE] key while the tray is being locked.
Progressive initialization	The progressive setting is initialized to Interlace.	① 00 RET ② 04 PRG	① While the unit is on, press and hold [OK], [B] and [Y] on the remote control at the same time for more than 5 seconds. - "00 RET" is displayed on the unit's display. ② Repeatedly press [▶] on the remote control or [POWER] on the unit until "04 PRG" is displayed on the unit's display. ③ Press and hold [OK] on the remote control or [OPEN/CLOSE] on the unit for at least 3 seconds.
Switch the TV system	Switch the TV system to another one.	① 00 RET ② 05 P/N	① While the unit is on, press and hold [OK], [B] and [Y] on the remote control at the same time for more than 5 seconds. - "00 RET" is displayed on the unit's display. ② Repeatedly press [▶] on the remote control or [POWER] on the unit until "05 P/N" is displayed on the unit's display. ③ Press and hold [OK] on the remote control or [OPEN/CLOSE] on the unit for at least 3 seconds.

Item		FL Display	Key Operation
Mode Name	Description		
Deep Colour Initialization	The Deep Colour setting is initialized.	① 00 RET ② 07 DC	① While the unit is on, press and hold [OK], [B] and [Y] on the remote control at the same time for more than 5 seconds. -"00 RET" is displayed on the unit's display. ② Repeatedly press [▶] on the remote control or [POWER] on the unit until "07 DC" is displayed on the unit's display. ③ Press and hold [OK] on the remote control or [OPEN/CLOSE] on the unit for at least 3 seconds.
CS reset	Reset the information about the following Service Mode. <ul style="list-style-type: none"> • Error History • BD Drive Last Error • Error Code • HDD Spin-up time • Laser Used Time 	① 70 RET ② 93 FIN ③ FACT	① While the unit is on, press and hold [5], [9] and [R] on the remote control at the same time for more than 5 seconds. -"70 RET" is displayed on the unit's display. ② Repeatedly press [▶] on the remote control or [POWER] on the unit until "93 FIN" is displayed on the unit's display. ③ Press [OK] on the remote control or [OPEN/CLOSE] on the unit for at least 3 seconds.
Diagnosis Code display	Display the Diagnosis Code	① 70 RET ② 96 DIC ③ Diagnosis in progress. Please Wait	① While the unit is on, press and hold [5], [9] and [R] on the remote control at the same time for more than 5 seconds. -"70 RET" is displayed on the unit's display. ② Repeatedly press [▶] on the remote control or [POWER] on the unit until "96 DIC" is displayed on the unit's display. ③ Press [OK] on the remote control or [OPEN/CLOSE] on the unit.

7.1.3. Service Modes at a glance

Information necessary for service can be displayed.

Service mode setting:

1. Turn the power off.
2. Press the [5] [9] and [R] button simultaneously for five seconds, then [70 RET] is displayed on FL.
3. Press the [▶] button to select until [80 SRV] is displayed on FL.
4. Press the [OK] button.
5. It is displayed on FL as [HELLO-->SERV].: It is shown to have entered the service mode.
6. The command is transmitted by attached remote control.





Method of making clear service mode: Press the power button (power off).

The display of information to each command is as follows.

NOTE:

Do not use it excluding the designated command.

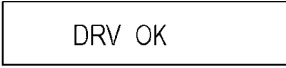
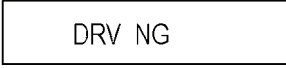
Item		FL Display	Key Operation
Mode Name	Description		(Remote controller key)
Release Items	Item of Service Mode executing is cancelled.	<div style="border: 1px solid black; padding: 5px; width: fit-content; margin: 0 auto;">SERV</div>	Press [0] [0] in service mode.
Error Code Display	Last Error Code of U/H/F held by Timer is displayed on FL. *Details are described in "7.1.1. Self-Diagnosis Functions".	<div style="border: 1px solid black; padding: 5px; width: fit-content; margin: 0 auto;">♣ □ □</div> <p>* ♣ shows U/H/F. □ □ shows number. If any error history does not exist, [F00] is displayed.</p>	Press [0] [1] in service mode
ROM Version Display	The display contents are switched over every 5 seconds. 1. Region code 2. Main firm version 3. Timer firm version 4. Drive firm version 5. ROM correction version 6. BOO2 version 7. BOO3 version 8. CDDB version 9. Voice version	<p>1. <div style="border: 1px solid black; padding: 5px; width: fit-content; margin: 0 auto;">NO_ \$%</div></p> <p>\$: Region of DVD (Example: 1,2.....) %: Region of BD (Example: A,B.....)</p> <p>2. <div style="border: 1px solid black; padding: 5px; width: fit-content; margin: 0 auto;">****</div></p> <p>3. <div style="border: 1px solid black; padding: 5px; width: fit-content; margin: 0 auto;">##O****</div></p> <p>##: Timer firm version O: OEM ***: Product number of microcomputer</p> <p>4. <div style="border: 1px solid black; padding: 5px; width: fit-content; margin: 0 auto;">****</div></p> <p>****: Drive version</p> <p>5. <div style="border: 1px solid black; padding: 5px; width: fit-content; margin: 0 auto;">***</div></p> <p>6. <div style="border: 1px solid black; padding: 5px; width: fit-content; margin: 0 auto;">***</div></p> <p>7. <div style="border: 1px solid black; padding: 5px; width: fit-content; margin: 0 auto;">***</div></p>	Press [0] [2] in service mode

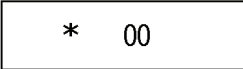
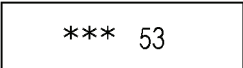
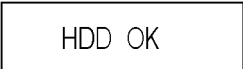
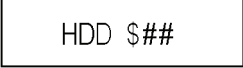
Item		FL Display	Key Operation (Remote controller key)
Mode Name	Description		
		8.  9. 	
Drive application check	Checking whether the drive is applicable drive or not.	When the drive is applicable drive.  When the drive is not applicable drive. 	Press [0] [3] in service mode.
HDD READ SEEK Inspection	Inspecting seek time of HDD to inspect performance .	At start  ↓  ↓ The [*] sign is added every approx.10 seconds while inspecting. Two digits on the right side are the progress level of the inspection (The unit is %). Example on the way of inspection:  When HDD is OK after inspection:  (NG is displayed when error is excluding 0) (Transfer rate is calculated from the AV scanning result, and when it is less than 35Mbps, NG is displayed.)  \$: [X] is displayed when seek time is over 270msec., there is error or transfer rate is NG. Position at \$ is space when excluding those. ##: Number of data of over 100msec. and less than 270msec. When it is over 100, [99] is displayed. When the number is less than 5, we judge it normal.	Press [3] [1] in service mode. * When canceling the inspection mode while executing, do "forced power-off". Method: Press [POWER] key on the main unit more than 4 seconds.

Item		FL Display	Key Operation (Remote controller key)
Mode Name	Description		
HDD READ VERIFY Inspection	Measure of access time in READ VERIFY MODE of HDD.	<p>At start</p> <div style="border: 1px solid black; padding: 5px; text-align: center; width: fit-content; margin: 0 auto;">AVSCAN</div> <p style="text-align: center;">↓</p> <div style="border: 1px solid black; padding: 5px; text-align: center; width: fit-content; margin: 0 auto;">* 00</div> <p style="text-align: center;">↓</p> <p>The [*] sign is added every approx 10 seconds while inspecting. Two digits on the right side are the progress level of the inspection (The unit is %). Example on the way of inspection:</p> <div style="border: 1px solid black; padding: 5px; text-align: center; width: fit-content; margin: 0 auto;">*** 53</div> <p>When HDD is OK after inspection:</p> <div style="border: 1px solid black; padding: 5px; text-align: center; width: fit-content; margin: 0 auto;">HDD OK</div> <p>(NG is displayed when error is excluding 0) (Transfer rate is calculated from the AV scanning result, and when it is less than 35Mbps, NG is displayed.)</p> <div style="border: 1px solid black; padding: 5px; text-align: center; width: fit-content; margin: 0 auto;">HDD \$##</div> <p>\$: [X] is displayed when seek time is over 270msec., there is error or transfer rate is NG. Position at \$ is space when excluding those. ##: Number of data of over 100msec. and less than 270msec. When it is over 100, [99] is displayed. When the number is less than 5, we judge it normal.</p>	<p>Press [3] [2] in service mode. * When canceling the inspection mode while executing, do "forced power-off". Method: Press [POWER] key on the main unit more than 4 seconds.</p>
HDD Spin-up time	The accumulation value of the Spin-up time of HDD is displayed.	<div style="border: 1px solid black; padding: 5px; text-align: center; width: fit-content; margin: 0 auto;">*****</div> <p>Spin-up time of HDD is displayed. (The unit of display is hour.)</p>	Press [3] [3] in service mode.

Item		FL Display	Key Operation (Remote controller key)
Mode Name	Description		
HDD Standard Speed Scan	Standard speed AV scan check of HDD	<div style="text-align: center;"> <div style="border: 1px solid black; padding: 5px; width: fit-content; margin: 0 auto;">AVSCAN</div> <p style="text-align: center;">↓</p> <div style="border: 1px solid black; padding: 5px; width: fit-content; margin: 0 auto;">STEP 1</div> <p style="text-align: center;">↓</p> <div style="border: 1px solid black; padding: 5px; width: fit-content; margin: 0 auto;">STEP 9</div> <p style="text-align: center;">↓</p> <div style="border: 1px solid black; padding: 5px; width: fit-content; margin: 0 auto;">* 00</div> <p style="text-align: center;">↓</p> <p>The [*] sign is added every 10 seconds while inspecting. Two digits on the right side are the progress level of the inspection (The unit is %). Example on the way of inspection:</p> <div style="border: 1px solid black; padding: 5px; width: fit-content; margin: 0 auto;">*** 53</div> <p>When HDD is OK after inspection:</p> <div style="border: 1px solid black; padding: 5px; width: fit-content; margin: 0 auto;">HDD OK</div> <p>When HDD is NG after inspection:</p> <div style="border: 1px solid black; padding: 5px; width: fit-content; margin: 0 auto;">HDD ***</div> <p>[*] is the number of data of NG.</p> </div>	Press[3] [6]in service mode. * When canceling the inspection mode while executing, do "forced power-off". Method: Press [POWER] key on the main unit more than 4 seconds.
HDD Check	Simple quality judgment of HDD	<div style="text-align: center;"> <div style="border: 1px solid black; padding: 5px; width: fit-content; margin: 0 auto;">HDDCHK</div> <p style="text-align: center;">↓</p> <p>When HDD is OK:</p> <div style="border: 1px solid black; padding: 5px; width: fit-content; margin: 0 auto;">HDD OK</div> <p>When HDD is NG:</p> <div style="border: 1px solid black; padding: 5px; width: fit-content; margin: 0 auto;">HDD NG</div> </div>	Press [3] [7] in service mode.

Item		FL Display	Key Operation (Remote controller key)
Mode Name	Description		
HDD/BD Drive Simple Check	<p>Check if HDD Self-Diagnosis test was performed or Drive last error occurred within 4 weeks.</p> <p>* If the current date or the date when the error occurred is wrong, correct judgement may not be made.</p>	<p>HDD Self-Diagnosis test start.</p> <div style="border: 1px solid black; padding: 5px; width: fit-content; margin: 5px auto;">HDDCHK</div> <p>When HDD Self-Diagnosis test result is OK.</p> <div style="border: 1px solid black; padding: 5px; width: fit-content; margin: 5px auto;">HDD OK</div> <p>When HDD Self-Diagnosis test result is NG.</p> <div style="border: 1px solid black; padding: 5px; width: fit-content; margin: 5px auto;">HDD NG</div> <p>When the drive malfunction was detected within 4 weeks ago.</p> <div style="border: 1px solid black; padding: 5px; width: fit-content; margin: 5px auto;">DRV NG</div> <p>When the drive malfunction was detected more than 4 weeks ago or Drive last error data does not exist.</p> <div style="border: 1px solid black; padding: 5px; width: fit-content; margin: 5px auto;">DRV OK</div> <p>[HDD OK] from [DRV OK] are repeatedly displayed in turn.</p>	Press [3][8] in service mode.
Laser Used Time Indication	Check laser used time (hours) of drive.	<p>Laser used time: BD Playback</p> <div style="border: 1px solid black; padding: 5px; width: fit-content; margin: 5px auto;">BP*****</div> <p>Laser used time: BD Recording</p> <div style="border: 1px solid black; padding: 5px; width: fit-content; margin: 5px auto;">BR*****</div> <p>Laser used time: DVD Playback</p> <div style="border: 1px solid black; padding: 5px; width: fit-content; margin: 5px auto;">DP*****</div> <p>Laser used time: DVD Recording</p> <div style="border: 1px solid black; padding: 5px; width: fit-content; margin: 5px auto;">DR*****</div> <p>Laser used time: CD Playback</p> <div style="border: 1px solid black; padding: 5px; width: fit-content; margin: 5px auto;">CD*****</div> <p>Display those repeatedly.</p> <ul style="list-style-type: none"> ●(*****) is the used time display in hour. ● Laser used time of BD/DVD/CD in Playback/Recording mode is counted. 	Press [4] [1] in service mode.

Item		FL Display	Key Operation (Remote controller key)
Mode Name	Description		
BD Drive Last Error	BD Drive error code display. * For details about the drive error code, refer to the Service Manual for the specific BD Drive.	<p>1. Error Number is displayed for 5 seconds.</p> <div style="border: 1px solid black; padding: 5px; width: fit-content; margin: 5px auto;">NO **</div> <p>2. Time when the error has occurred is display for 5 seconds.</p> <div style="border: 1px solid black; padding: 5px; width: fit-content; margin: 5px auto;">YYMMDD</div> <p>YY: Year MM: Month DD: Day</p> <p>3. Last drive error (1/2) is displayed for 5 seconds.</p> <div style="border: 1px solid black; padding: 5px; width: fit-content; margin: 5px auto;">*****</div> <p>00 : Bad disc 03 : Bad disc 04 : Bad disc or drive malfunction</p> <p>4. Last drive error (2/2) is displayed for five seconds.</p> <div style="border: 1px solid black; padding: 5px; width: fit-content; margin: 5px auto;">*****</div> <p>5. Error occurring disc type is displayed for 5 seconds.</p> <p>DVD ROM</p> <div style="border: 1px solid black; padding: 5px; width: fit-content; margin: 5px auto;">DVD</div> <p>CD</p> <div style="border: 1px solid black; padding: 5px; width: fit-content; margin: 5px auto;">CD</div> <p>DVD-RAM (2.6GB)</p> <div style="border: 1px solid black; padding: 5px; width: fit-content; margin: 5px auto;">RAM26</div> <p>DVD-RAM (4.7GB)</p> <div style="border: 1px solid black; padding: 5px; width: fit-content; margin: 5px auto;">RAM47</div> <p>DVD-R</p> <div style="border: 1px solid black; padding: 5px; width: fit-content; margin: 5px auto;">DVDR</div> <p>DVD-RW</p> <div style="border: 1px solid black; padding: 5px; width: fit-content; margin: 5px auto;">DVDRW</div> <p>CD-R</p> <div style="border: 1px solid black; padding: 5px; width: fit-content; margin: 5px auto;">CDR</div>	Press [4] [2] in service mode.

Item		FL Display	Key Operation (Remote controller key)
Mode Name	Description		
		CD-RW <div style="border: 1px solid black; padding: 5px; width: fit-content; margin: 5px auto;">CDRW</div>	
		DVD+R <div style="border: 1px solid black; padding: 5px; width: fit-content; margin: 5px auto;">DVDPR</div>	
		DVD+RW <div style="border: 1px solid black; padding: 5px; width: fit-content; margin: 5px auto;">DVDPRW</div>	
		BD-ROM <div style="border: 1px solid black; padding: 5px; width: fit-content; margin: 5px auto;">BDROM</div>	
		BD-RE <div style="border: 1px solid black; padding: 5px; width: fit-content; margin: 5px auto;">BDRE</div>	
		BD-R <div style="border: 1px solid black; padding: 5px; width: fit-content; margin: 5px auto;">BDR</div>	
		BD-ROM(Multiple Layer) <div style="border: 1px solid black; padding: 5px; width: fit-content; margin: 5px auto;">BDXROM</div>	
		BD-RE(Multiple Layer) <div style="border: 1px solid black; padding: 5px; width: fit-content; margin: 5px auto;">BDXRE</div>	
		BD-R(Multiple Layer) <div style="border: 1px solid black; padding: 5px; width: fit-content; margin: 5px auto;">BDXR</div>	
		Others <div style="border: 1px solid black; padding: 5px; width: fit-content; margin: 5px auto;">MEDIA*</div>	
		* s displayed the resposed value from RTSC. 6. Disc maker ID is displayed for 5 seconds.	In case that the maker cannot be identified, display is black out.
		<div style="border: 1px solid black; padding: 5px; width: fit-content; margin: 5px auto;">*****</div>	

Item		FL Display	Key Operation (Remote controller key)																																																																																																					
Mode Name	Description																																																																																																							
		<p>7. Factor of drive error (hexadecimal) occurring is left displayed.</p> <div style="border: 1px solid black; padding: 5px; width: fit-content; margin: 10px auto;">* * + + & &</div> <p>* * : Error occurring operation code (This is not used)</p> <p>+ + : Error occurring disc type</p> <table border="1" style="margin-left: 20px;"> <tr><td>00</td><td>DVD-ROM</td></tr> <tr><td>01</td><td>CD</td></tr> <tr><td>02</td><td>2.6GB DVD-RAM</td></tr> <tr><td>03</td><td>4.7GB DVD-RAM</td></tr> <tr><td>04</td><td>DVD-R</td></tr> <tr><td>After 05</td><td>Others</td></tr> </table> <p>&& : Error occurring disc situation</p> <table border="1" style="margin-left: 20px;"> <thead> <tr> <th rowspan="2">Display</th> <th colspan="4">Detail</th> </tr> <tr> <th>Disc distinction</th> <th>With or without Cartridge</th> <th>Disc cartridge state</th> <th>Size</th> </tr> </thead> <tbody> <tr><td>00</td><td>OK</td><td>With</td><td>Not opened</td><td>12cm</td></tr> <tr><td>10</td><td>OK</td><td>With</td><td>Not opened</td><td>8cm</td></tr> <tr><td>20</td><td>OK</td><td>With</td><td>Opened</td><td>12cm</td></tr> <tr><td>30</td><td>OK</td><td>With</td><td>Opened</td><td>8cm</td></tr> <tr><td>40</td><td>OK</td><td>Without</td><td>Not opened</td><td>12cm</td></tr> <tr><td>50</td><td>OK</td><td>Without</td><td>Not opened</td><td>8cm</td></tr> <tr><td>60</td><td>OK</td><td>Without</td><td>Opened</td><td>12cm</td></tr> <tr><td>70</td><td>OK</td><td>Without</td><td>Opened</td><td>8cm</td></tr> <tr><td>80</td><td>NG</td><td>With</td><td>Not opened</td><td>12cm</td></tr> <tr><td>90</td><td>NG</td><td>With</td><td>Not opened</td><td>8cm</td></tr> <tr><td>A0</td><td>NG</td><td>With</td><td>Opened</td><td>12cm</td></tr> <tr><td>B0</td><td>NG</td><td>With</td><td>Opened</td><td>8cm</td></tr> <tr><td>C0</td><td>NG</td><td>Without</td><td>Not opened</td><td>12cm</td></tr> <tr><td>D0</td><td>NG</td><td>Without</td><td>Not opened</td><td>8cm</td></tr> <tr><td>E0</td><td>NG</td><td>Without</td><td>Opened</td><td>12cm</td></tr> <tr><td>F0</td><td>NG</td><td>Without</td><td>Opened</td><td>8cm</td></tr> </tbody> </table> <p>8. When the last error doesn't exist.</p> <div style="border: 1px solid black; padding: 5px; width: fit-content; margin: 10px auto;">NO DATA</div>	00	DVD-ROM	01	CD	02	2.6GB DVD-RAM	03	4.7GB DVD-RAM	04	DVD-R	After 05	Others	Display	Detail				Disc distinction	With or without Cartridge	Disc cartridge state	Size	00	OK	With	Not opened	12cm	10	OK	With	Not opened	8cm	20	OK	With	Opened	12cm	30	OK	With	Opened	8cm	40	OK	Without	Not opened	12cm	50	OK	Without	Not opened	8cm	60	OK	Without	Opened	12cm	70	OK	Without	Opened	8cm	80	NG	With	Not opened	12cm	90	NG	With	Not opened	8cm	A0	NG	With	Opened	12cm	B0	NG	With	Opened	8cm	C0	NG	Without	Not opened	12cm	D0	NG	Without	Not opened	8cm	E0	NG	Without	Opened	12cm	F0	NG	Without	Opened	8cm	
00	DVD-ROM																																																																																																							
01	CD																																																																																																							
02	2.6GB DVD-RAM																																																																																																							
03	4.7GB DVD-RAM																																																																																																							
04	DVD-R																																																																																																							
After 05	Others																																																																																																							
Display	Detail																																																																																																							
	Disc distinction	With or without Cartridge	Disc cartridge state	Size																																																																																																				
00	OK	With	Not opened	12cm																																																																																																				
10	OK	With	Not opened	8cm																																																																																																				
20	OK	With	Opened	12cm																																																																																																				
30	OK	With	Opened	8cm																																																																																																				
40	OK	Without	Not opened	12cm																																																																																																				
50	OK	Without	Not opened	8cm																																																																																																				
60	OK	Without	Opened	12cm																																																																																																				
70	OK	Without	Opened	8cm																																																																																																				
80	NG	With	Not opened	12cm																																																																																																				
90	NG	With	Not opened	8cm																																																																																																				
A0	NG	With	Opened	12cm																																																																																																				
B0	NG	With	Opened	8cm																																																																																																				
C0	NG	Without	Not opened	12cm																																																																																																				
D0	NG	Without	Not opened	8cm																																																																																																				
E0	NG	Without	Opened	12cm																																																																																																				
F0	NG	Without	Opened	8cm																																																																																																				

Item		FL Display	Key Operation (Remote controller key)															
Mode Name	Description																	
Laser power test	Drive state is judged based on difference between laser power value at shipping and present laser power value.	<p>Measuring starts (Measuring in process).</p> <div style="border: 1px solid black; padding: 5px; width: fit-content; margin: 5px auto;">POWER</div> <p>When the measuring result is OK.</p> <div style="border: 1px solid black; padding: 5px; width: fit-content; margin: 5px auto;">OK *</div> <p>When the measuring result is NG.</p> <div style="border: 1px solid black; padding: 5px; width: fit-content; margin: 5px auto;">NG *</div> <p>When DVD-RAM is not inserted.</p> <div style="border: 1px solid black; padding: 5px; width: fit-content; margin: 5px auto;">NODISC</div> <p>When an error occurs while measuring.</p> <div style="border: 1px solid black; padding: 5px; width: fit-content; margin: 5px auto;">ERROR</div> <p>* is judgement result</p> <table border="1" style="margin: 5px auto;"> <thead> <tr> <th>*</th> <th>Power value difference</th> <th>Evaluation</th> </tr> </thead> <tbody> <tr> <td>0</td> <td>1mW or less</td> <td>Very good.</td> </tr> <tr> <td>1</td> <td>2mW or less</td> <td>Good.</td> </tr> <tr> <td>2</td> <td>3mW or less</td> <td>Bad.</td> </tr> <tr> <td>3</td> <td>4mW or more</td> <td>Very bad.</td> </tr> </tbody> </table> <p>If disc in not inserteed, [NO DISC] is displayed. If power value study was filed, [ERROR] is displayed.</p>	*	Power value difference	Evaluation	0	1mW or less	Very good.	1	2mW or less	Good.	2	3mW or less	Bad.	3	4mW or more	Very bad.	<p>1. Insert the 5X media DVD-RAM into the tray. (Incompatible with other media) 2. Press [4] [4].</p>
*	Power value difference	Evaluation																
0	1mW or less	Very good.																
1	2mW or less	Good.																
2	3mW or less	Bad.																
3	4mW or more	Very bad.																
CEC (H) output	Check of the CEC terminal high output of HDMI.	<p>When the check is OK</p> <div style="border: 1px solid black; padding: 5px; width: fit-content; margin: 5px auto;">CECHOK</div> <p>When the check is NG</p> <div style="border: 1px solid black; padding: 5px; width: fit-content; margin: 5px auto;">CECHNG</div>	Press [5] [5] in service mode.															
CEC (L) output	Check of the CEC terminal low output of HDMI.	<p>When the check is OK</p> <div style="border: 1px solid black; padding: 5px; width: fit-content; margin: 5px auto;">CECLOK</div> <p>When the check is NG</p> <div style="border: 1px solid black; padding: 5px; width: fit-content; margin: 5px auto;">CECLNG</div>	Press [5] [6] in service mode.															
Production Date Display	Display the date when the unit was produced.	<div style="border: 1px solid black; padding: 5px; width: fit-content; margin: 5px auto;">YYMMDD</div> <p>YY: Year MM: Month DD: Day</p>	Press [6] [1] in service mode.															

Item		FL Display	Key Operation (Remote controller key)
Mode Name	Description		
Display the Error History	Display the Error History stored on the unit. * If the current date or the date when the error occurred is wrong, correct judgement may not be made.	<p>When the drive malfunction was detected within 4 weeks ago. (*)</p> <div style="border: 1px solid black; padding: 2px; width: fit-content; margin: 5px auto;">DRV NG</div> <p>When the drive malfunction was detected more than 4 weeks ago or Drive last error data does not exist.</p> <div style="border: 1px solid black; padding: 2px; width: fit-content; margin: 5px auto;">DRV OK</div> <p>When HDD Self-Diagnosis test result is NG.</p> <div style="border: 1px solid black; padding: 2px; width: fit-content; margin: 5px auto;">HDD NG</div> <p>When HDD Self-Diagnosis test result is OK.</p> <div style="border: 1px solid black; padding: 2px; width: fit-content; margin: 5px auto;">HDD OK</div> <p>The Error History is not Data for HDD and BD Drive.</p> <div style="border: 1px solid black; padding: 2px; width: fit-content; margin: 5px auto;">OK</div> <p>The Error History is not Data.</p> <div style="border: 1px solid black; padding: 2px; width: fit-content; margin: 5px auto;">NODATA</div> <p>HDD Self-Diagnosis test in process.</p> <div style="border: 1px solid black; padding: 2px; width: fit-content; margin: 5px auto;">HDDCHK</div>	Press [6] [5] in service mode.
Save the error history to SD card (BWT760GN)	The error and user operation history of the remote control are saved to the SD card.	<p>The SD card cannot be recognized</p> <div style="border: 1px solid black; padding: 2px; width: fit-content; margin: 5px auto;">NOCARD</div> <p>During saving</p> <div style="border: 1px solid black; padding: 2px; width: fit-content; margin: 5px auto;">SDSAVE</div> <p>Save end</p> <div style="border: 1px solid black; padding: 2px; width: fit-content; margin: 5px auto;">FIN</div>	Press [6] [9] in service mode.
Registration of additional USB HDD	To register USB HDD for inspection. (Special mode)	<p>When USB HDD is in Special mode (available for registered USB HDD):</p> <div style="border: 1px solid black; padding: 2px; width: fit-content; margin: 5px auto;">EXTHDD</div> <p>When Special mode failure (USB-HDD registration impossible):</p> <div style="border: 1px solid black; padding: 2px; width: fit-content; margin: 5px auto;">EXT NG</div>	<p>Press [7] [4] in service mode.</p> <p>* When releasing this mode, press the [POWER] button of the unit or Remote Control. After releasing the special mode, registration in the special mode is cancelled. Details are described in "3.1.3.1. Registering the USB HDD".</p>

Item		FL Display	Key Operation
Mode Name	Description		(Remote controller key)
USB HDD READ SEEK Inspection	Inspecting seek time of USB HDD to inspect performance.	<p>At start</p> <div style="border: 1px solid black; padding: 5px; text-align: center; margin-bottom: 5px;">AVSCAN</div> <p style="text-align: center;">↓</p> <div style="border: 1px solid black; padding: 5px; text-align: center; margin-bottom: 5px;">* 00</div> <p style="text-align: center;">↓</p> <p>The [*] sign is added every approx. 10 seconds while inspecting. Two digits on the right side are the progress level of the inspection (The unit is %). Example on the way of inspection:</p> <div style="border: 1px solid black; padding: 5px; text-align: center; margin-bottom: 5px;">*** 53</div> <p>When USB HDD is OK after inspection:</p> <div style="border: 1px solid black; padding: 5px; text-align: center; margin-bottom: 5px;">HDD OK</div> <p>(NG is displayed when error is excluding 0) (Transfer rate is calculated from the AV scanning result, and when it is less than 35Mbps, NG is displayed.)</p> <div style="border: 1px solid black; padding: 5px; text-align: center; margin-bottom: 5px;">HDD\$##</div> <p>\$: [X] is displayed when seek time is over 270msec., there is error or transfer rate is NG. Position at \$ is space when excluding those. ##: Number of data of over 100msec. and less than 270msec. When it is over 100, [99] is displayed. When the number is less than 5, we judge it normal. When the USB HDD is not applicable.</p> <div style="border: 1px solid black; padding: 5px; text-align: center; margin-bottom: 5px;">NO_SUP</div>	<p>Press [7] [5] in service mode. * When cancelling the inspection mode while executing, do "forced power-off". Method: Press [POWER] key on the main unit more than 4 seconds.</p>

Item		FL Display	Key Operation (Remote controller key)
Mode Name	Description		
USB HDD READ VERIFY Inspection	Measure of access time in READ VERIFY MODE of USB HDD.	<p>At start</p> <div style="border: 1px solid black; padding: 5px; text-align: center; width: fit-content; margin: 5px auto;">AVSCAN</div> <p style="text-align: center;">↓</p> <div style="border: 1px solid black; padding: 5px; text-align: center; width: fit-content; margin: 5px auto;">* 00</div> <p style="text-align: center;">↓</p> <p>The [*] sign is added every approx. 10 seconds while inspecting. Two digits on the right side are the progress level of the inspection (The unit is %). Example on the way of inspection:</p> <div style="border: 1px solid black; padding: 5px; text-align: center; width: fit-content; margin: 5px auto;">*** 53</div> <p>When USB HDD is OK after inspection:</p> <div style="border: 1px solid black; padding: 5px; text-align: center; width: fit-content; margin: 5px auto;">HDD OK</div> <p>(NG is displayed when error is excluding 0) (Transfer rate is calculated from the AV scanning result, and when it is less than 35Mbps, NG is displayed.)</p> <div style="border: 1px solid black; padding: 5px; text-align: center; width: fit-content; margin: 5px auto;">HDD\$##</div> <p>\$: [X] is displayed when seek time is over 270msec., there is error or transfer rate is NG. Position at \$ is space when exclud- ing those. ##: Number of data of over 100msec. and less than 270msec. When it is over 100, [99] is displayed. When the number is less than 5, we judge it normal. When the USB HDD is not applicable.</p> <div style="border: 1px solid black; padding: 5px; text-align: center; width: fit-content; margin: 5px auto;">NO_SUP</div>	<p>Press [7] [6] in service mode. * When cancelling the inspection mode while executing, do "forced power-off". Method: Press [POWER] key on the main unit more than 4 seconds.</p>

Item		FL Display	Key Operation (Remote controller key)
Mode Name	Description		
USB HDD Simple AV Scan Check	Simple AV scan check of USB HDD	<div style="text-align: center;"> <div style="border: 1px solid black; padding: 5px; width: fit-content; margin: 0 auto;">AVSCAN</div> <p style="text-align: center;">↓</p> <div style="border: 1px solid black; padding: 5px; width: fit-content; margin: 0 auto;">STEP 1</div> <p style="text-align: center;">↓</p> <div style="border: 1px solid black; padding: 5px; width: fit-content; margin: 0 auto;">STEP 9</div> <p style="text-align: center;">↓</p> <div style="border: 1px solid black; padding: 5px; width: fit-content; margin: 0 auto;">* 00</div> <p style="text-align: center;">↓</p> </div> <p>The [*] sign is added every 10 seconds while inspecting. Two digits on the right side are the progress level of the inspection (The unit is %). Example on the way of inspection:</p> <div style="text-align: center;"> <div style="border: 1px solid black; padding: 5px; width: fit-content; margin: 0 auto;">*** 53</div> </div> <p>When USB HDD is OK after inspection:</p> <div style="text-align: center;"> <div style="border: 1px solid black; padding: 5px; width: fit-content; margin: 0 auto;">HDD OK</div> </div> <p>When USB HDD is NG after inspection:</p> <div style="text-align: center;"> <div style="border: 1px solid black; padding: 5px; width: fit-content; margin: 0 auto;">HDD ***</div> </div> <p>[*] is the number of data of NG.</p>	<p>Press [7] [7] in service mode. * When cancelling the inspection mode while executing, do "forced power-off". Method: Press [POWER] key on the main unit more than 4 seconds.</p>
USB HDD Check	Simple quality judgement of USB HDD	<div style="text-align: center;"> <div style="border: 1px solid black; padding: 5px; width: fit-content; margin: 0 auto;">HDDCHK</div> <p style="text-align: center;">↓</p> </div> <p>When USB HDD is OK:</p> <div style="text-align: center;"> <div style="border: 1px solid black; padding: 5px; width: fit-content; margin: 0 auto;">HDD OK</div> </div> <p>When USB HDD is NG:</p> <div style="text-align: center;"> <div style="border: 1px solid black; padding: 5px; width: fit-content; margin: 0 auto;">HDD NG</div> </div>	<p>Press [7] [8] in service mode.</p>
Tray OPEN/CLOSE Test	The tray is opened and closed repeatedly.	<div style="text-align: center;"> <div style="border: 1px solid black; padding: 5px; width: fit-content; margin: 0 auto;">*****</div> </div> <p>“*” is number of open/close cycle times.</p>	<p>Press [9] [1] in service mode *When releasing this mode, press the [POWER] button of Remote Controller.</p>

Item		FL Display	Key Operation
Mode Name	Description		(Remote controller key)
Delete the Laser Used Time	Laser used time stored in the memory of the unit is deleted.	CLR	Press [9] [5] in service mode.
Delete the Last Drive Error	Delete the Last Drive Error information stored on the BD Drive.	CLR	Press [9] [6] in service mode.
Delete the Error History	Delete Error History information stored on the unit is deleted.	CLR	Press [9] [7] in service mode.
Error code Initialization	Information of the last error code held by timer. (Write in F00)	CLR	Press [9] [8] in service mode.
Initialize Service	Last Drive Error, Error History and Error code information stored on the unit are initialized to factory setting.	CLR	Press [9] [9] in service mode.
Finishing service mode	Release Service Mode.	Display in STOP (E-E) mode. *****	Press power button on the front panel or Remote controller in service mode.

8 Service Fixture & Tools

Part Number	Description	Pcs	Compatibility
RFKZ0216	Extension Cable (Digital P.C.B. - Main P.C.B./ 23 Pin)	1	Same as BWT945GL Series
RFKZ0578	Extension Cable (Digital P.C.B. - HDD / 7 Pin)	1	Same as BWT945GL Series
RFKZ0577	Extension Cable (Digital P.C.B. - HDD / 15 Pin)	1	Same as BWT945GL Series
SUKZ000007 (*1)	Extension Cable (Digital P.C.B. - BD Drive / 18 Pin)	1	Same as BWT945GL Series
RFKZ0323	Extension Cable (Digital P.C.B. - Main P.C.B / 9 Pin)	1	Same as UN-10E5 Series
RFKZ0614	Extension Cable (Digital P.C.B. - Main P.C.B / 15 Pin)		same as BWT550 Series
SVKZ000004	Lead Free Solder (0.3mm/100g Reel)		Same as BWT945GL Series
SVKZ000005	Lead Free Solder (0.6mm/100g Reel)		Same as BWT945GL Series
SVKZ000006	Lead Free Solder (1.0mm/100g Reel)		Same as BWT945GL Series
RFKZ0316	Solder Remover (Lead free low temperature Solder/50g)		Same as BWT945GL Series
RFKZ0328	Flux		Same as BWT945GL Series

* The above parts are supplied by AVC-CSC-SPC.

*1. Supplied by CHPAVC.

9 Disassembly and Assembly Instructions

9.1. DMR-BWT460GN

9.1.1. Disassembly flow chart

The following chart is the procedure for disassembling the casing and inside parts for internal inspection when carrying out the servicing.

To assemble the unit, reverse the steps shown in the chart below.

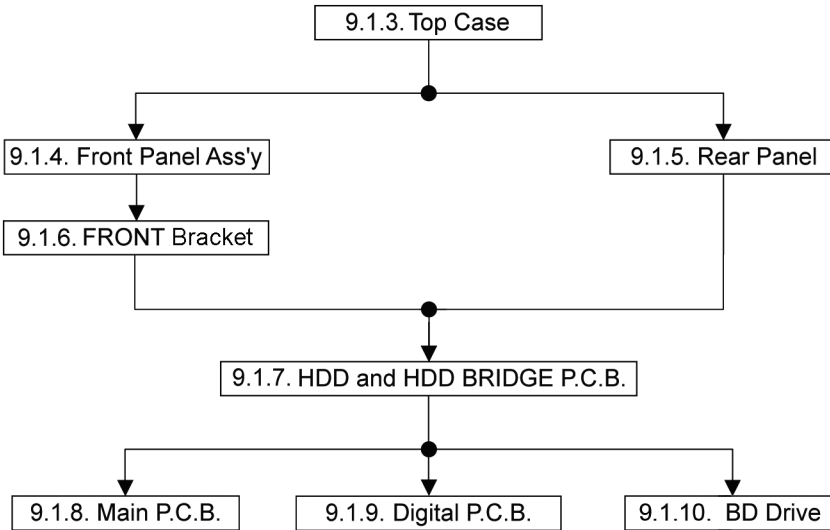

9.1.2. P.C.B. Positions

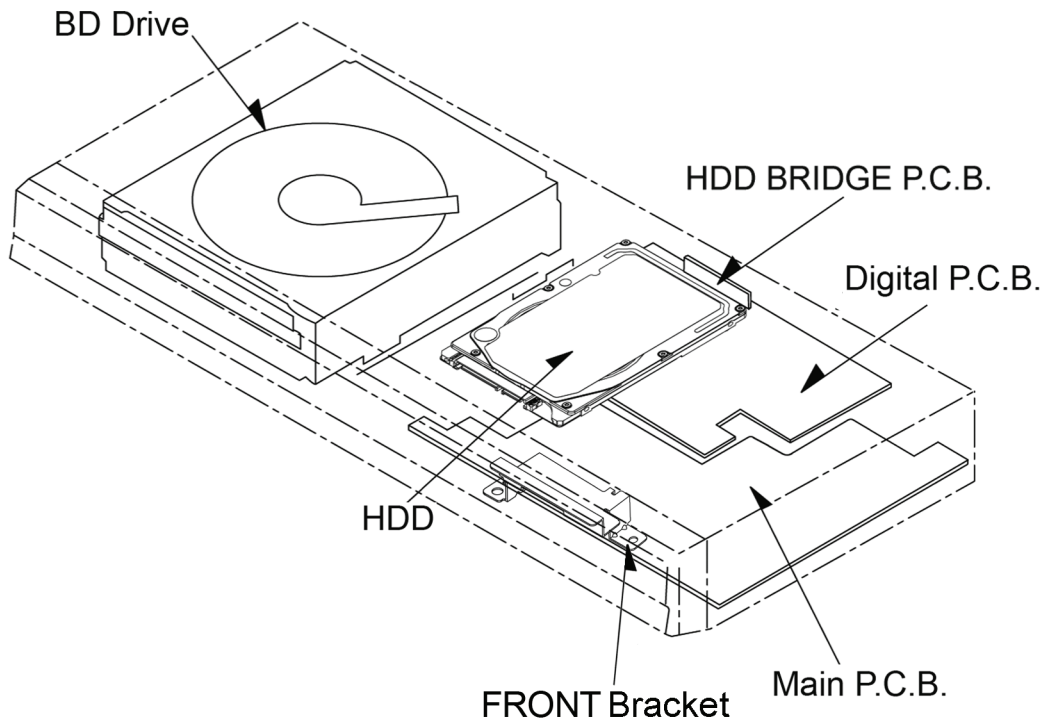

9.1.3. Top Case

1. Remove the 2 screws (A) and 3 screws (B).

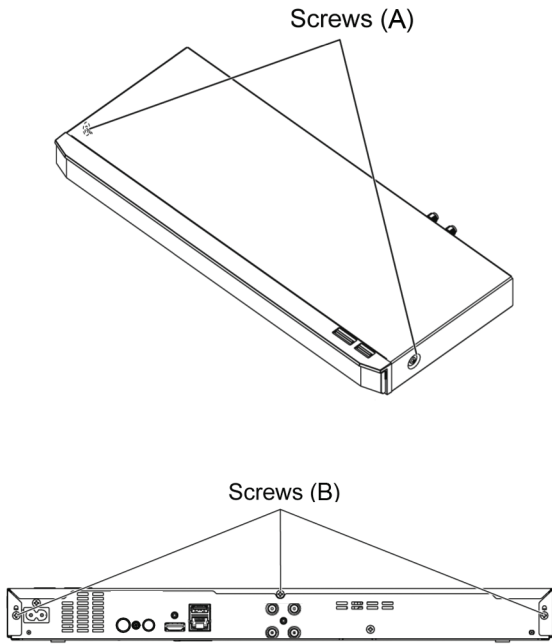

2. Slide the Top Case rearward and open the both ends at rear side of the Top Case a little and lift the Top Case in the direction of the arrows.

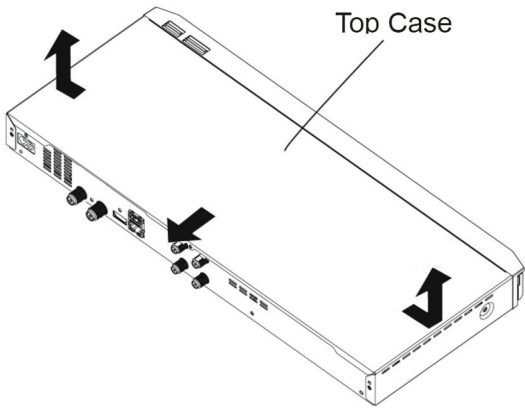

9.1.4. Front Panel Ass'y

1. Unlock 6 tabs (A) - (G).
2. Pull with the front panel in the direction of your side.

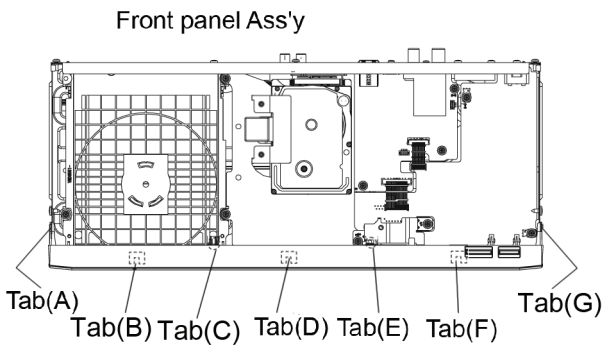

9.1.4.1. How to assemble Door ass'y

1. Application of the Lubricant to Door Ass'y.
 - a. Lubrication points on Door ass'y and Front Panel are shown in the figure as below.

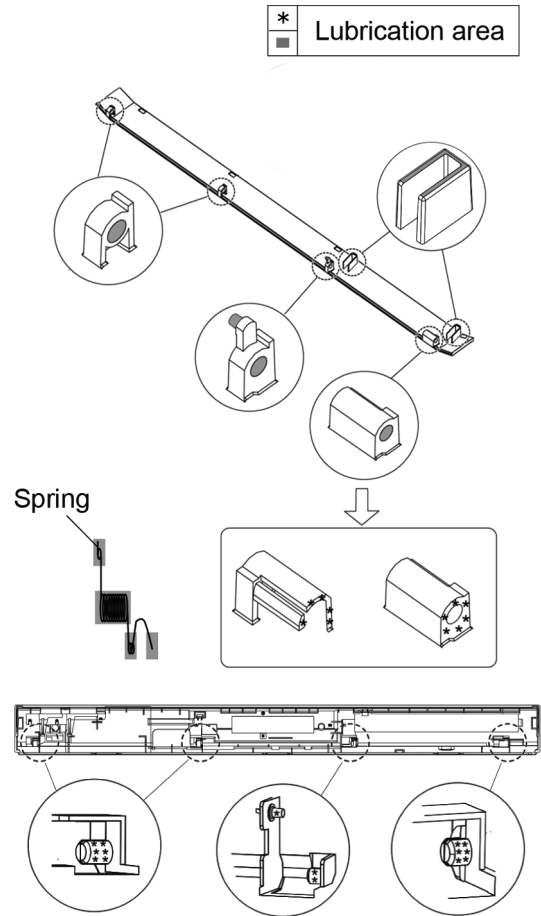

- b. Since the replaced parts are not lubricated, please apply lubricant to the specified points (RFKXGUD24)
- c. Use Cotton Swab to spread thinly.

2. Install each roller of the door in the sequence as shown in the figure.

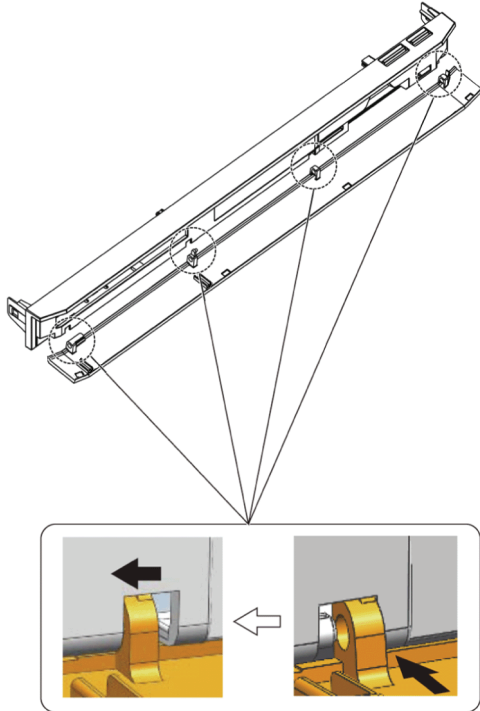

3. Install each roller of the door in the sequence as shown in the figure.

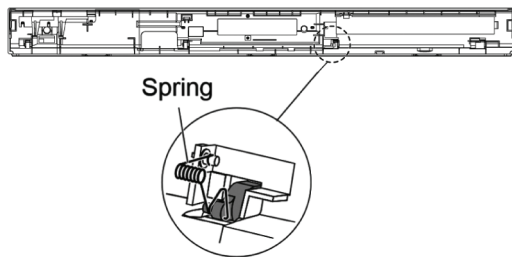

9.1.5. Rear Panel

1. Remove 3 Screws (A) and 2 Screws (B).

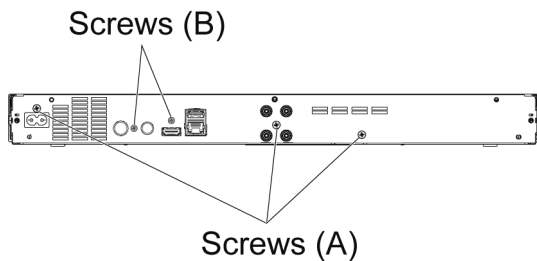

2. Unlock 2 locking tabs(C) to remove Rear Panel.

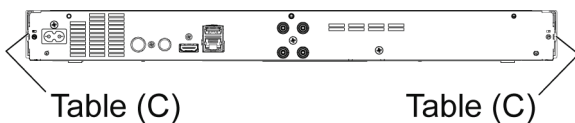

9.1.6. FRONT Bracket

1. Remove 2 Screws (A), to remove FRONT Bracket.

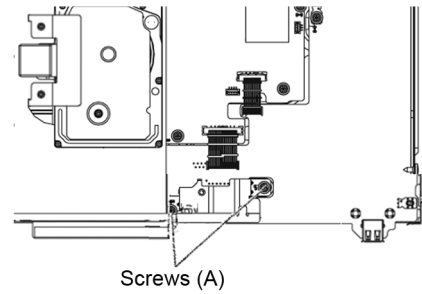

9.1.7. HDD and HDD BRIDGE P.C.B.

Data of HDD:

Make sure to order the Part No., TZTHD***** in Replacement Parts List when replacing the HDD.

The following data has been written on TZTHD*****.

- Main Firm
- CD DB Data
- Other Data

Caution:

No use HDD (TZTHD*****) of the capacity of the other model use.

When replacing HDD, "HDD Error" indication is displayed and HDD must be formatted.

*How to format HDD

Please refer to Service Navigation, and Format HDD.

Handling of HDD

The following precautions should be taken when handling HDD.

- a. Never give an impact to HDD. (Even a drop from 1cm height can be a cause of HDD failure.
- b. When placing HDD on a workbench, provide a mat on a bench for shock absorption and anti-static purposes.
- c. When installing HDD, release it from your hands only after confirming that it is fully set on the chassis.
- d. Avoid stacking up HDD.
- e. HDD is unstable and easy to fall. Do not stand it on its side face.
- f. When handling HDD, hold its side faces to avoid static hazard.
- g. Do not place HDD on its wrapping bag after removal. (Prevention of static hazard)
- h. Use a screwdriver with low impact and anti-static features.

Note:

When replacing HDD, please make the rear jumper slave or cable select configuration.

1. Disconnect the Connector (A), Remove 3 Screws (A), to remove HDD Ass'y.

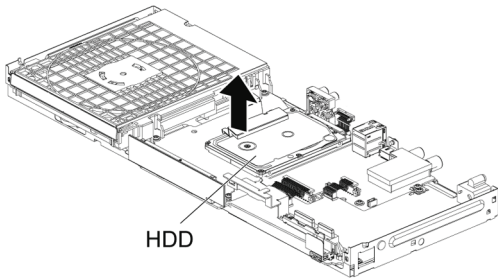
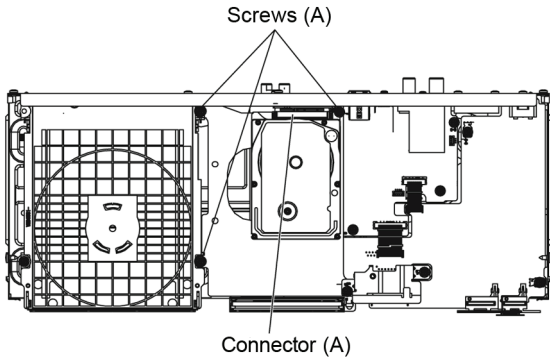

Notes:

Put HDD up and down inversely so as not to give a shock to HDD.

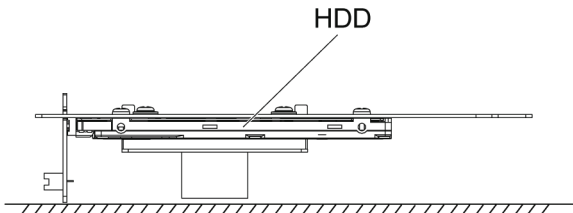

2. Remove 2 Screws (A), to remove Radiator Sheet and Radiator Bracket from HDD Bracket.

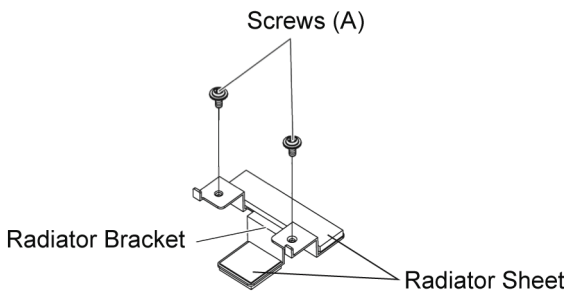

3. Remove 2 Screws (B) to remove HDD from HDD Bracket.

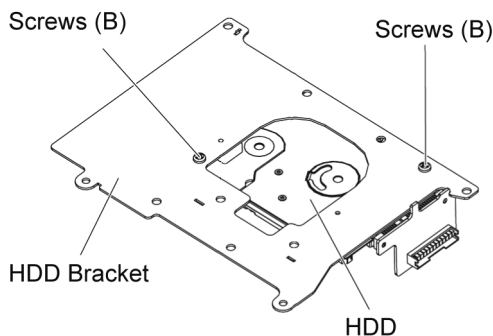

4. Pull up HDD BRIDGE P.C.B. in the direction of the arrow.

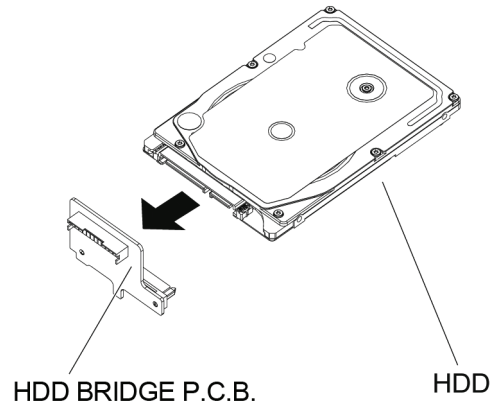

9.1.8. Main P.C.B.

When replacing Main P.C.B., "HDD Error" indication is displayed and HDD must be formatted.

*How to format HDD
Please refer to Service Navigation, and Format HDD.

1. Remove 2 Screws (A), Disconnect the connector (A) and (B), to remove Main P.C.B..

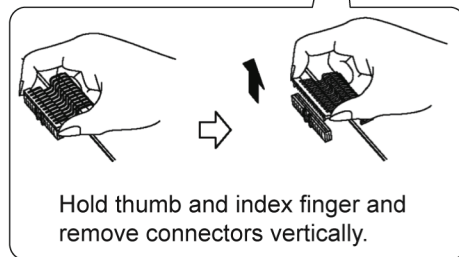
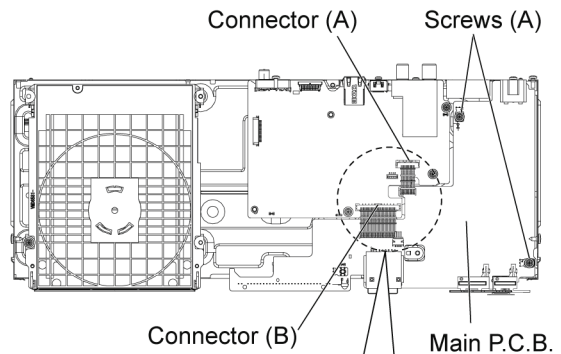

9.1.9. Digital P.C.B.

1. Remove 3 Screws (A), Disconnect the Connector (A), (B) and the DRIVE FFC, to remove Digital P.C.B..

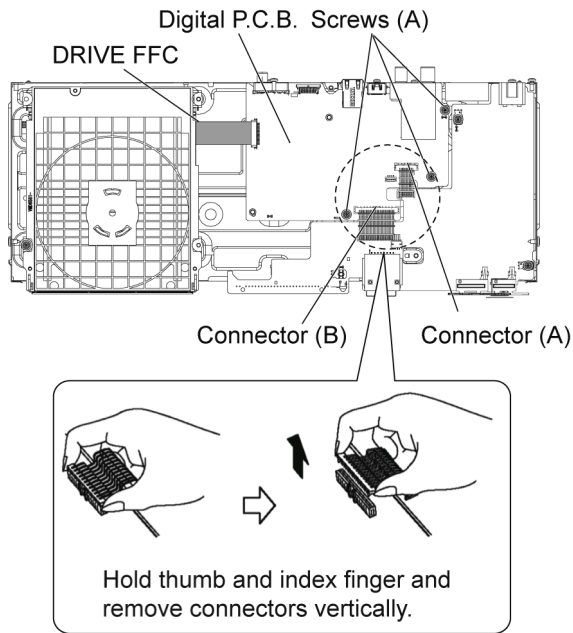

9.1.10. BD Drive

1. Disconnect the connector of DRIVE FFC.
2. Remove 1 Screws (A), to remove BD Drive.

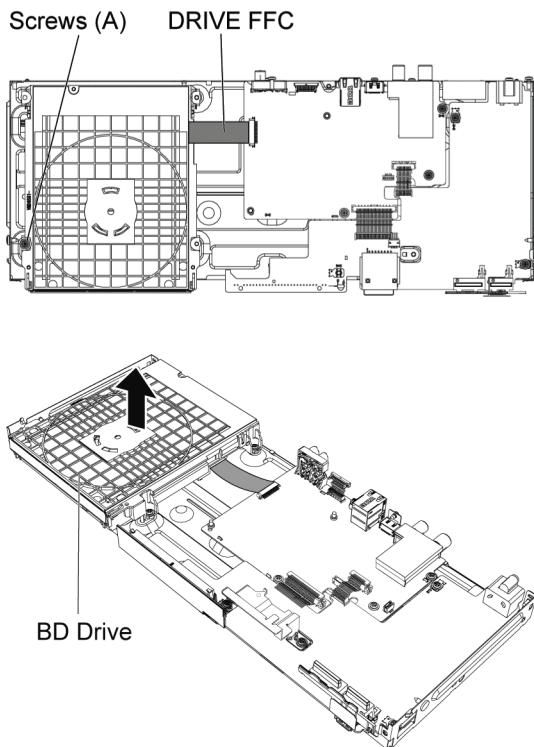

9.2. DMR-BWT760GN

9.2.1. Disassembly flow chart

The following chart is the procedure for disassembling the casing and inside parts for internal inspection when carrying out the servicing.

To assemble the unit, reverse the steps shown in the chart below.

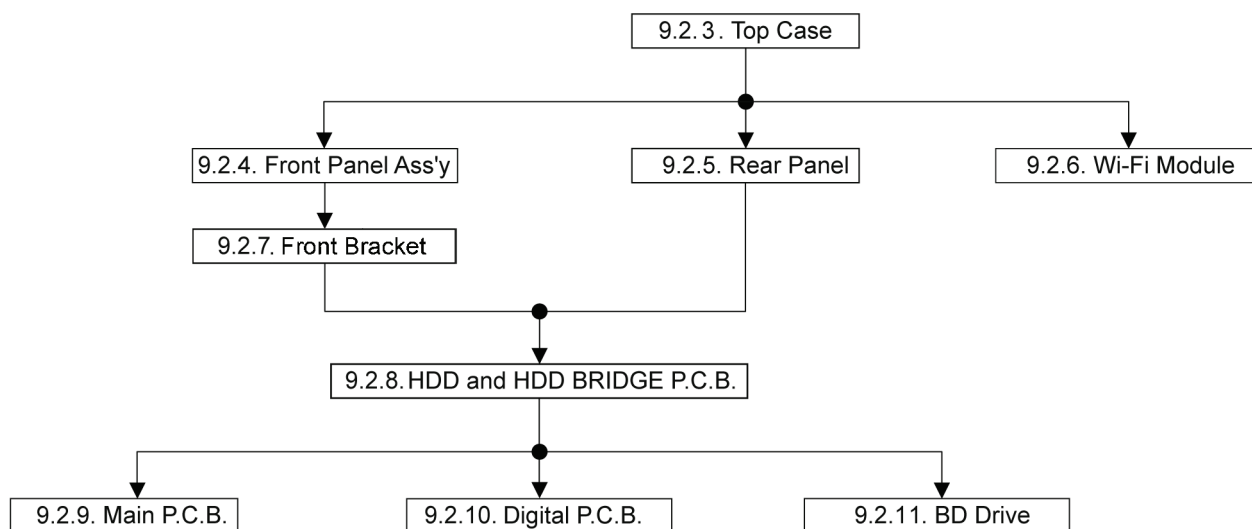

9.2.2. P.C.B. Positions

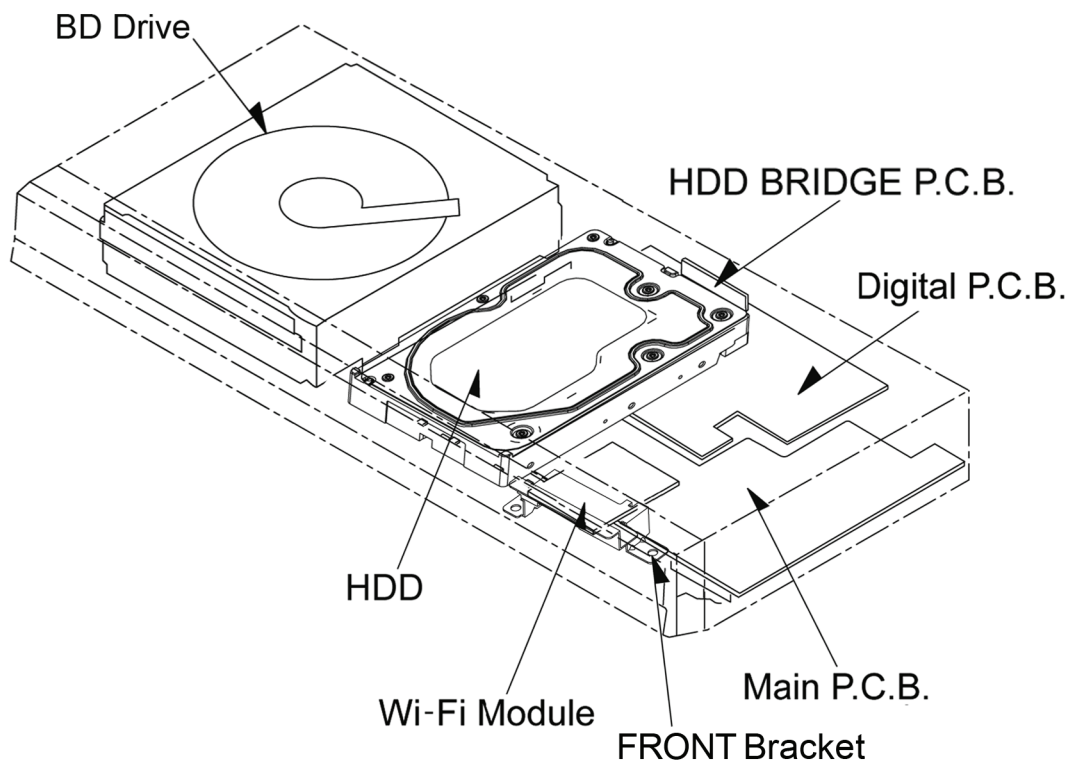

9.2.3. Top Case

1. Remove the 2 screws (A) and 3 screws (B).

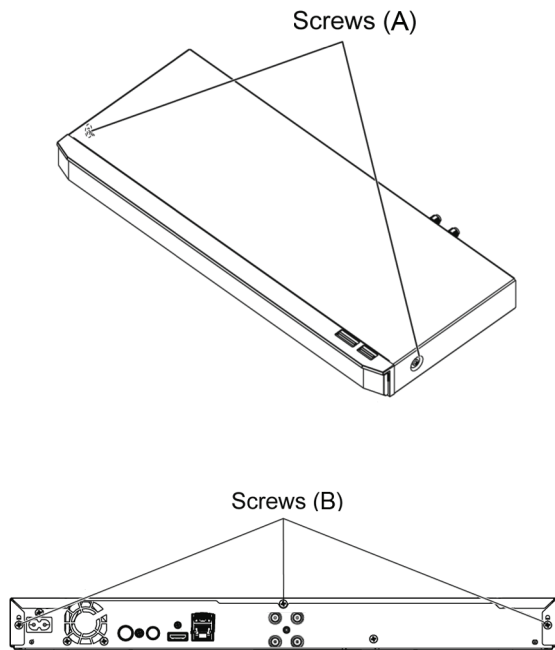

2. Slide the Top Case rearward and open the both ends at rear side of the Top Case a little and lift the Top Case in the direction of the arrows.

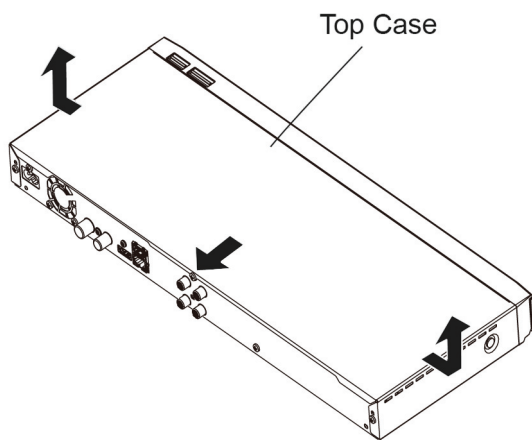

9.2.4. Front Panel Ass'y

1. Unlock 6 tabs (A) - (G).
2. Pull with the front panel in the direction of your side.

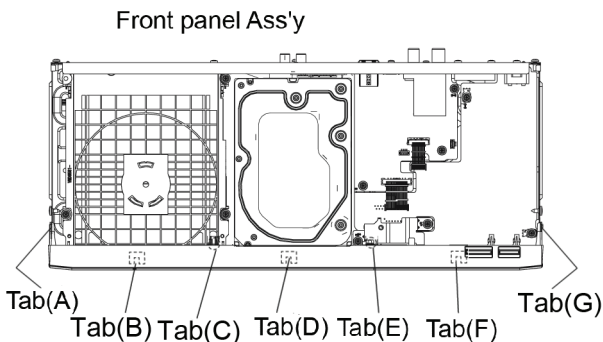

9.2.4.1. How to assemble Door ass'y

1. Application of the Lubricant to Door Ass'y.
 - a. Lubrication points on Door ass'y and Front Panel are shown in the figure as below.

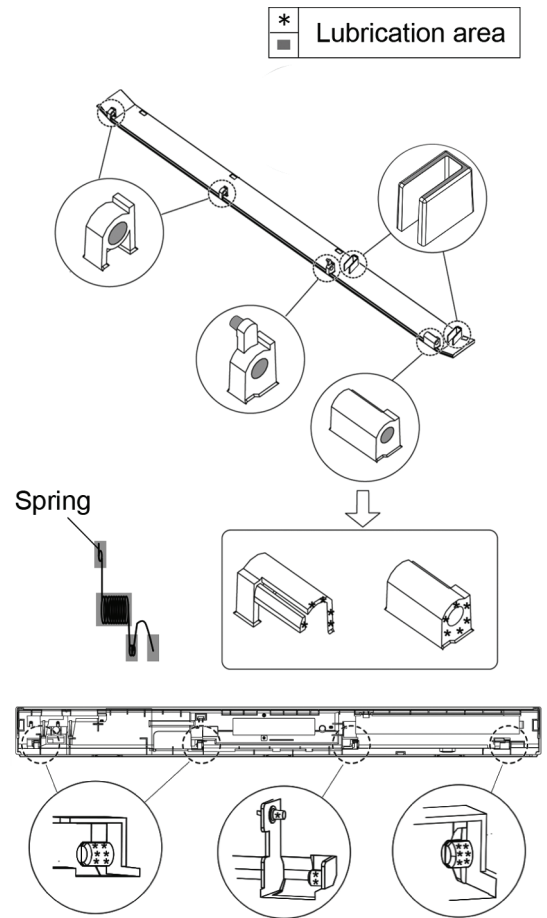

- b. Since the replaced parts are not lubricated, please apply lubricant to the specified points (RFKXGUD24)
- c. Use Cotton Swab to spread thinly.

2. Install each roller of the door in the sequence as shown in the figure.

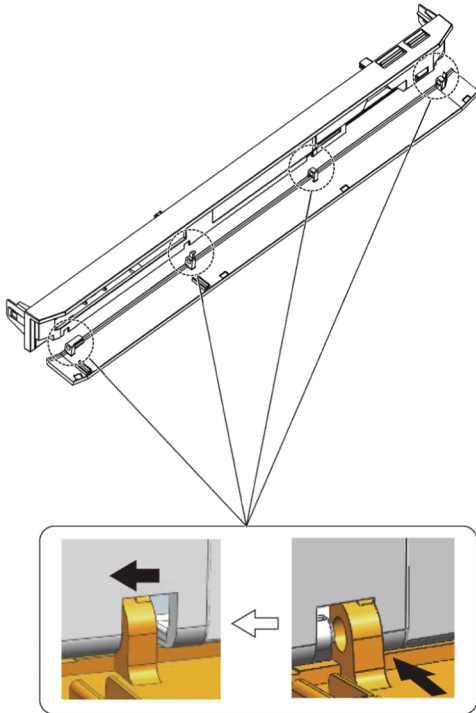

3. Install each roller of the door in the sequence as shown in the figure.

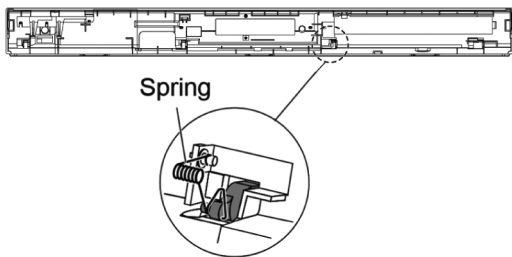

9.2.5. Rear Panel

1. Remove 3 Screws (A) and 2 Screws (B).

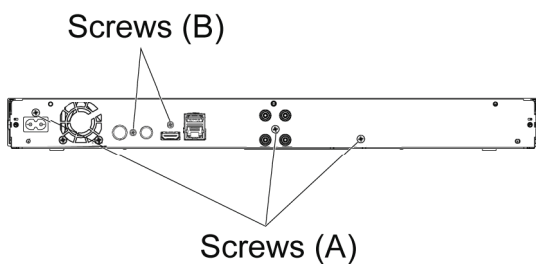

2. Disconnect the Fan connector and unlock 2 locking tabs (C) to remove Rear Panel.

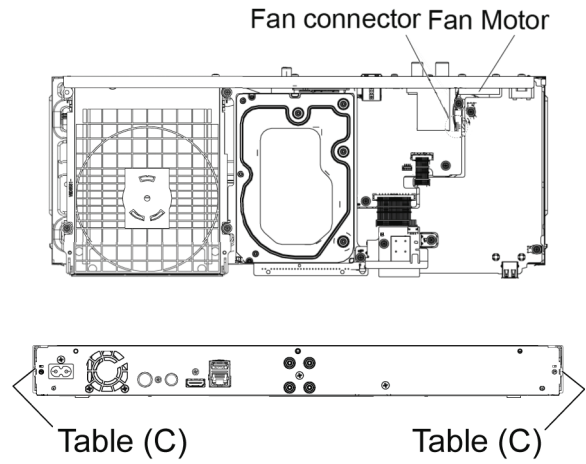

3. Remove the 2 screws (A), to remove FAN.

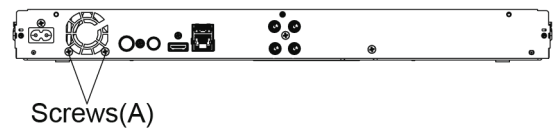

9.2.6. Wi-Fi Module

1. Remove 1 Screws (A), Disconnect the wi-fi Connector (A), to remove WI-FI Module.

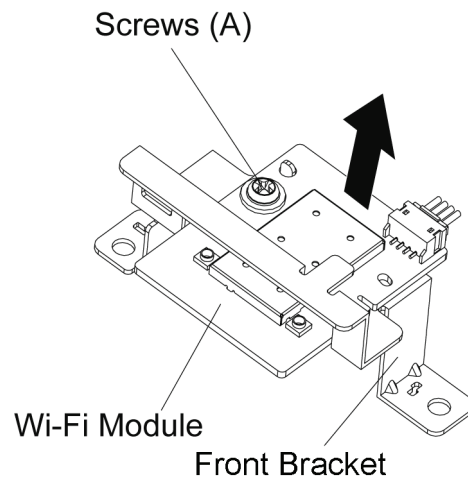

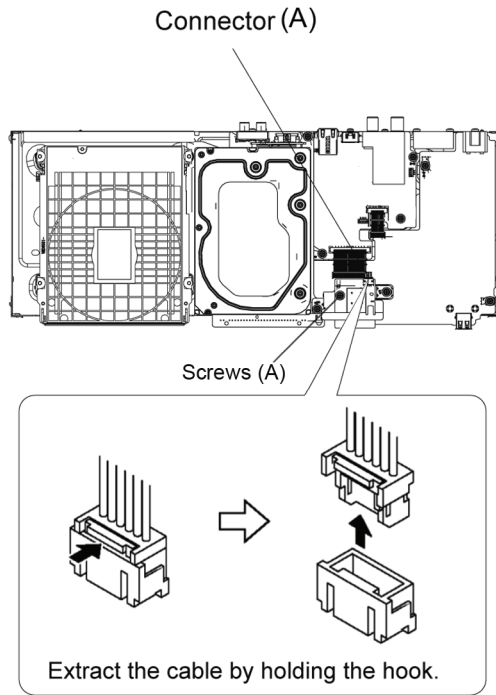

Handling of HDD

- The following precautions should be taken when handling HDD.
- Never give an impact to HDD. (Even a drop from 1cm height can be a cause of HDD failure.)
 - When placing HDD on a workbench, provide a mat on a bench for shock absorption and anti-static purposes.
 - When installing HDD, release it from your hands only after confirming that it is fully set on the chassis.
 - Avoid stacking up HDD.
 - HDD is unstable and easy to fall. Do not stand it on its side face.
 - When handling HDD, hold its side faces to avoid static hazard.
 - Do not place HDD on its wrapping bag after removal. (Prevention of static hazard)
 - Use a screwdriver with low impact and anti-static features.

Note:

When replacing HDD, please make the rear jumper slave or cable select configuration.

- Disconnect the Connector (A), Remove 3 Screws (A), to remove HDD Ass'y.

9.2.7. Front Bracket

- Remove 2 Screws (A), to remove FRONT Bracket.

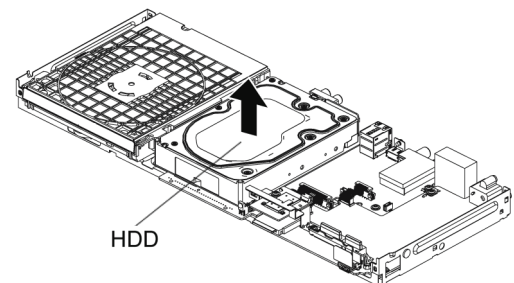
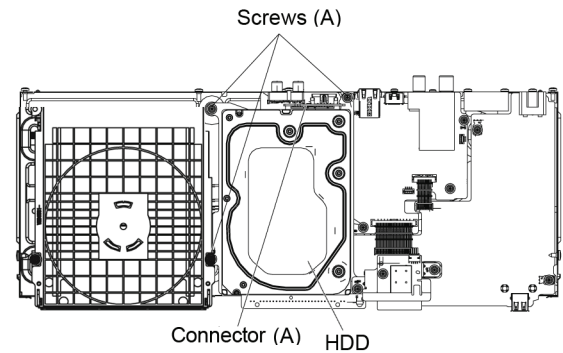
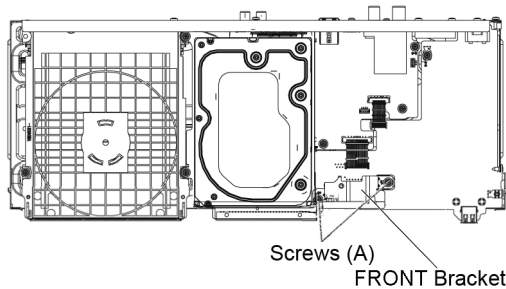

9.2.8. HDD and HDD BRIDGE P.C.B.

Data of HDD:

Make sure to order the Part No., TZTHD***** in Replacement Parts List when replacing the HDD.

The following data has been written on TZTHD*****.

- Main Firm
- CD DB Data
- Other Data

Caution:

No use HDD (TZTHD*****) of the capacity of the other model use.

Notes:

Put HDD up and down inversely so as not to give a shock to HDD.

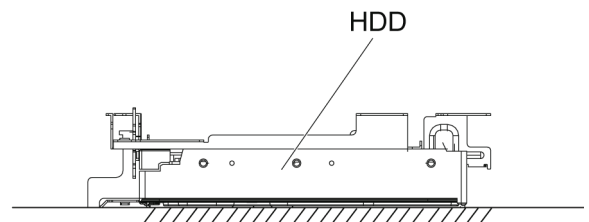

When replacing HDD, "HDD Error" indication is displayed and HDD must be formatted.

*How to format HDD

Please refer to Service Navigation, and Format HDD.

2. Remove 4 Screws (B) to remove HDD from HDD Bracket.

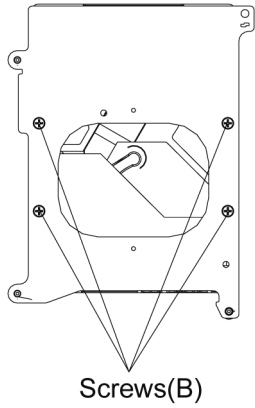

3. Pull up HDD BRIDGE P.C.B. in the direction of the arrow.

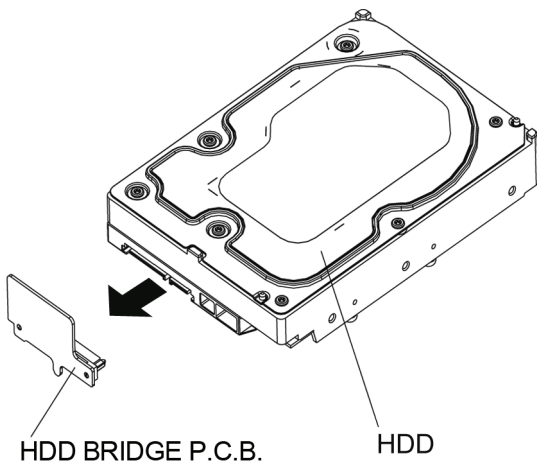

9.2.9. Main P.C.B.

When replacing Main P.C.B., "HDD Error" indication is displayed and HDD must be formatted.

*How to format HDD
Please refer to Service Navigation,
and Format HDD.

1. Remove 2 Screws (A), Disconnect the Connector (A) and (B), to remove Main P.C.B..

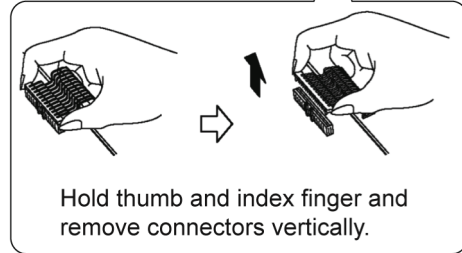
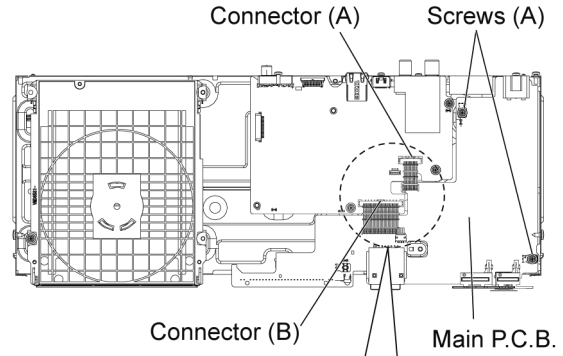

9.2.10. Digital P.C.B.

1. Remove 3 Screws (A), Disconnect the Connector (A), (B) and the DRIVE FFC, to remove Digital P.C.B..

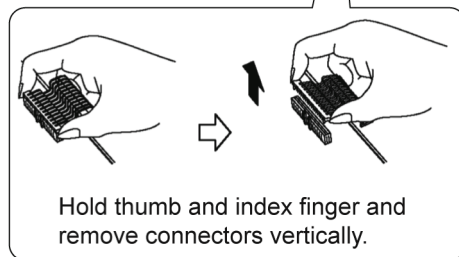
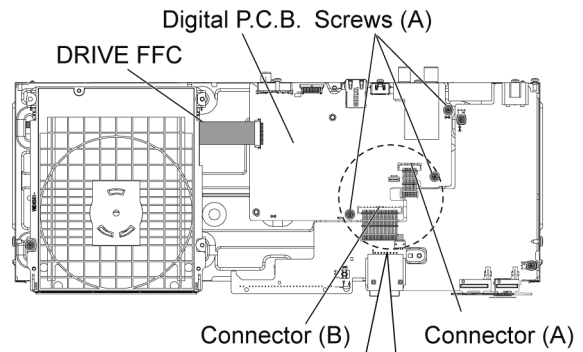

9.2.11. BD Drive

1. Disconnect the connector of DRIVE FFC.
2. Remove 1 Screws (A), to remove BD Drive.

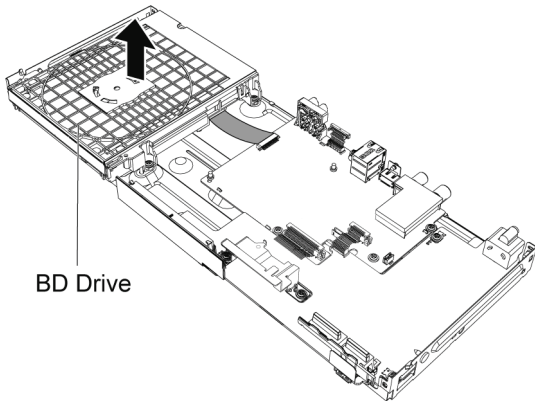
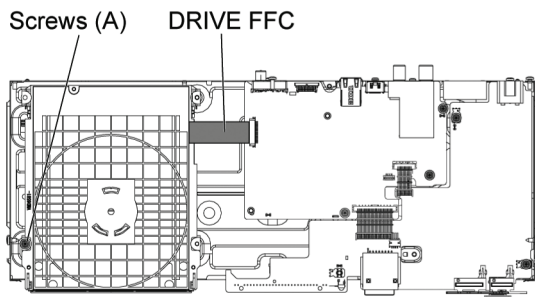

2. Lift up the Upper Base Ass'y, and pull it out to the direction of arrow.

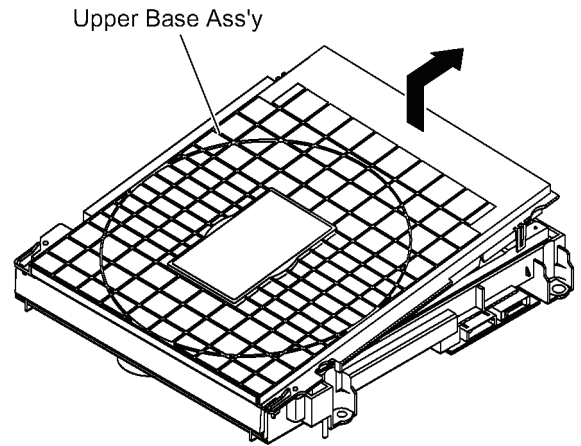

9.3.2. Tray

1. Perform the step "9.12.1.Upper Base Ass'y".
2. Insert the Paper Clip into the hole of the bottom side, and slide it to the direction of arrow until it can be.

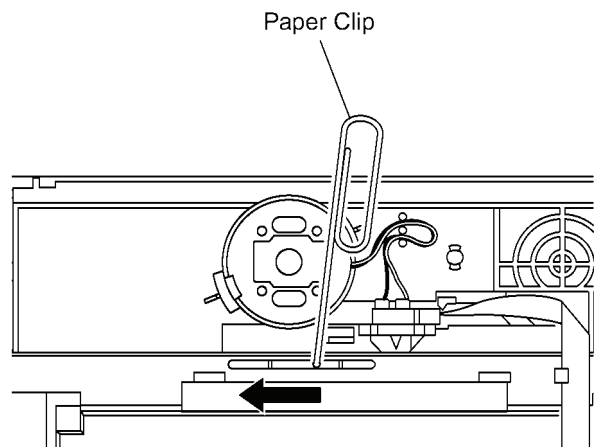

3. Pull the Tray to the direction of arrow.

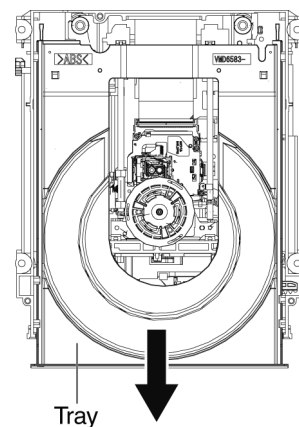

9.3. BD Drive

9.3.1. Upper Base Ass'y

1. Remove 3 Screws (A), and push the 2 Hooks in.

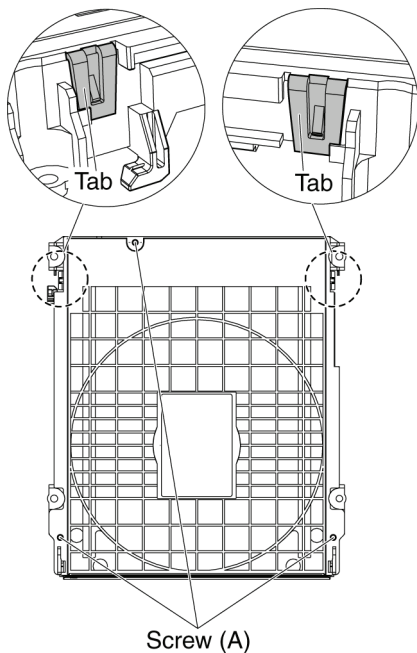

Notes when attaching the tray:

Pull the Slide Cam to the left side and insert the tray when attaching.

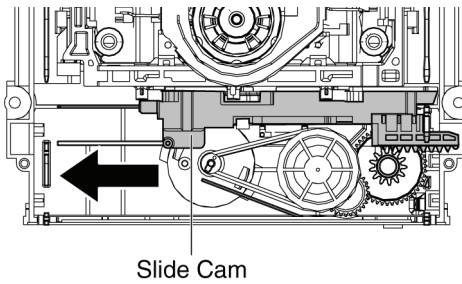

9.3.3. Pulley Gear, Belt and Mid Gear

1. Perform the step "9.12.2.Tray".
2. Push the post to the direction of arrow by using the slotted screwdriver.

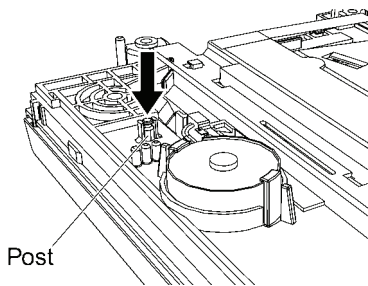

3. Remove the Pulley Gear, Belt and Mid Gear.

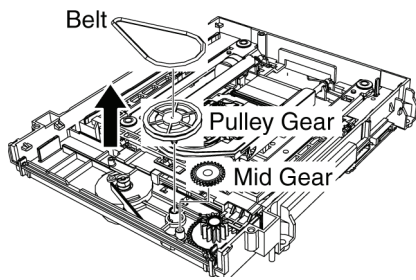

9.3.4. Slide Cam

1. Perform the step "9.12.3.Pulley Gear,Belt and Mid Gear".
2. Remove the sheet.
3. Open the connector lock, and disconnect the 4 FFCs.

4. Remove the Screw (A), Heat Sink and Drive P.C.B..

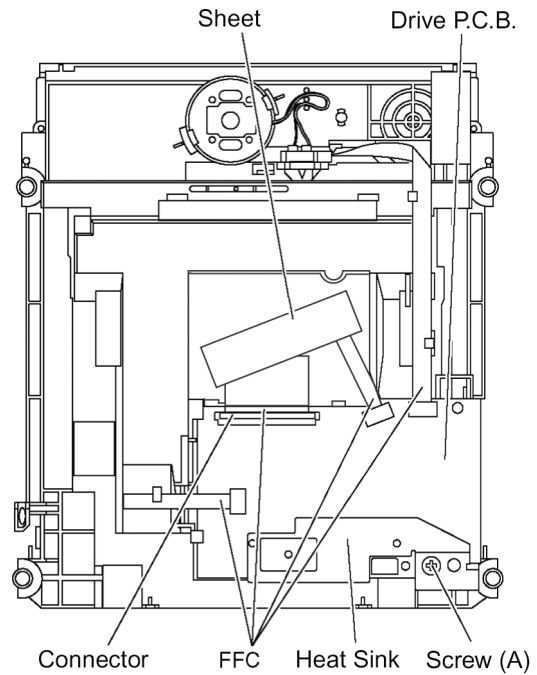

Caution:

Though the Drive P.C.B. is not supplied as replacement parts, it must be removed for after disassembling.

5. Remove the 2 Dampers.

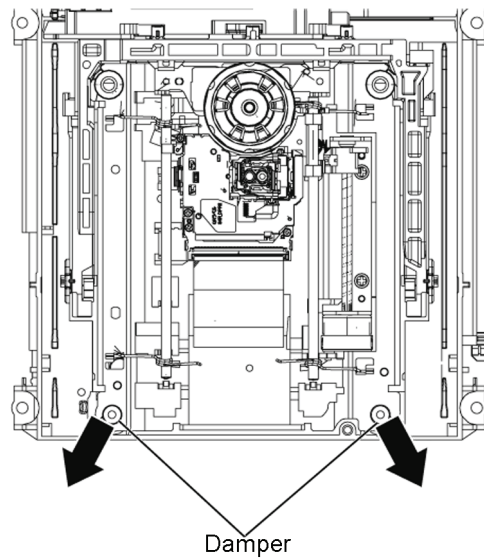

6. Open the connector lock, and disconnect the OPU FFC.
7. Pull the Slide Cam to the right side.

8. Remove the Traverse Base Ass'y with spreading the 2 Hooks to the direction of arrows.

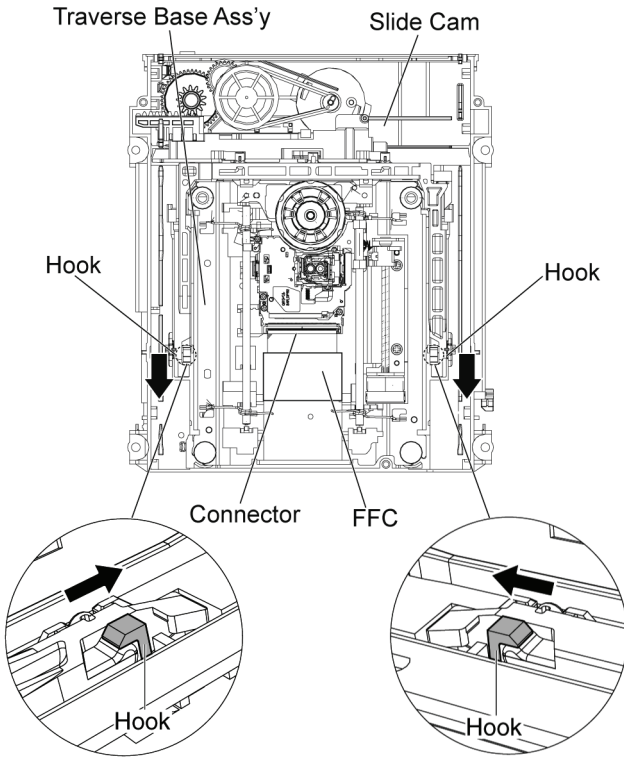

9. Remove the Slide Cam.

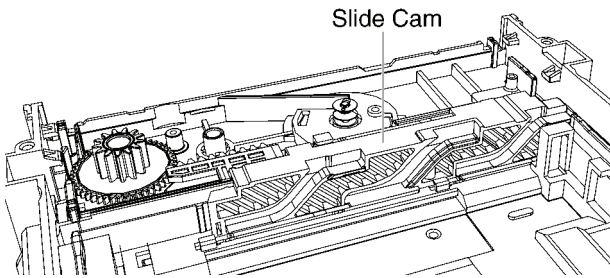

9.3.5. Drive Gear and Loading Motor

1. Perform the step "9.12.4.Slide Cam".
2. Remove the Drive Gear.

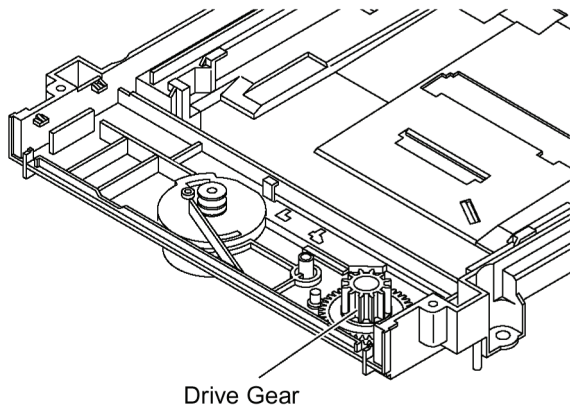

3. Remove the 2 soldering points.

4. Spread the 2 hooks to remove the Loading Motor.

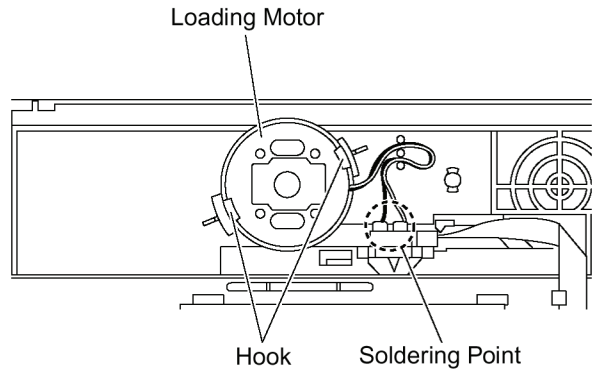

Notes when assembling:

- a. Align the location hole of the loading motor with the base dowel pin.
- b. The fixing style for the wire rod of the loading motor is shown in the figure.
- c. The stationary jaw of FFC is shown in the figure.

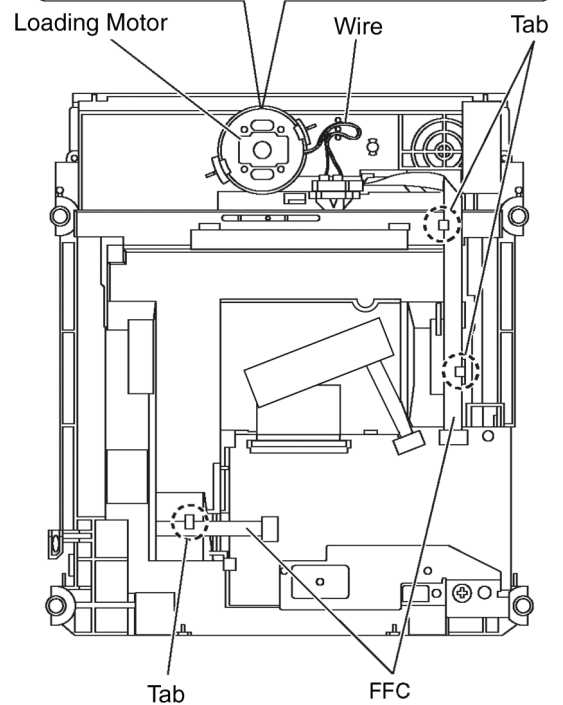
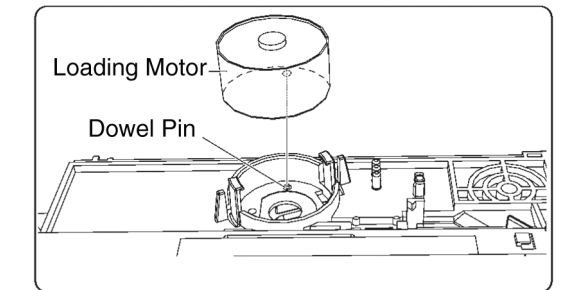

9.3.6. Grease

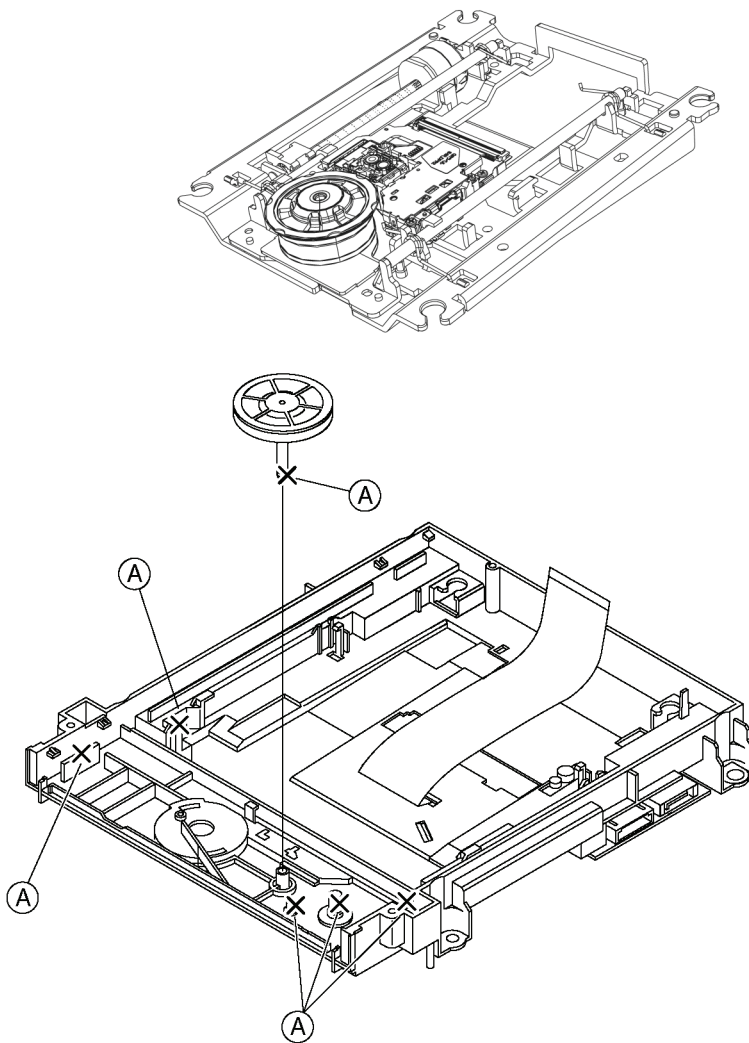
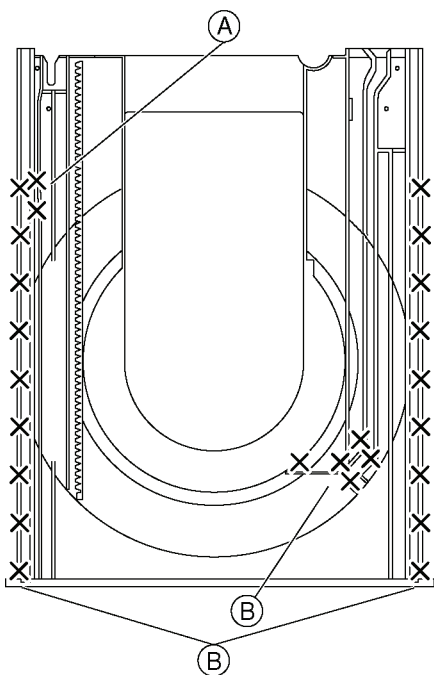
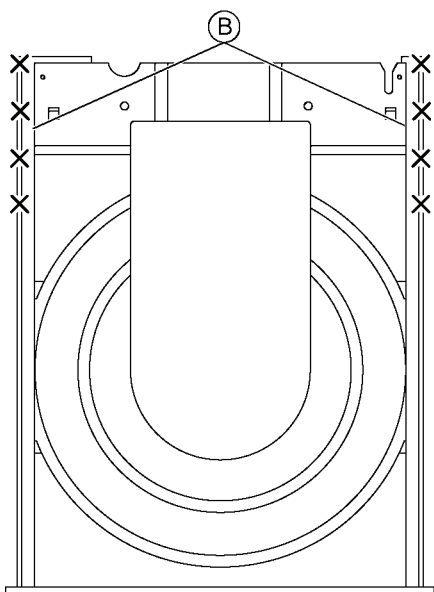
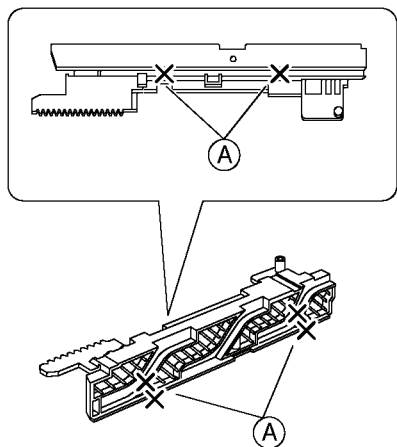

LUBRICATION POINTS

When the above parts are replaced, apply the recommended lubricants or adhesive for better maintenance of the unit.

Mark	Kind of lubricant	Part No.
Ⓐ	Grease	RFKZ0484
Ⓑ	Hanarl	RFKZ0441

9.3.7. How to Clean the Lens of Optical Pick-UP

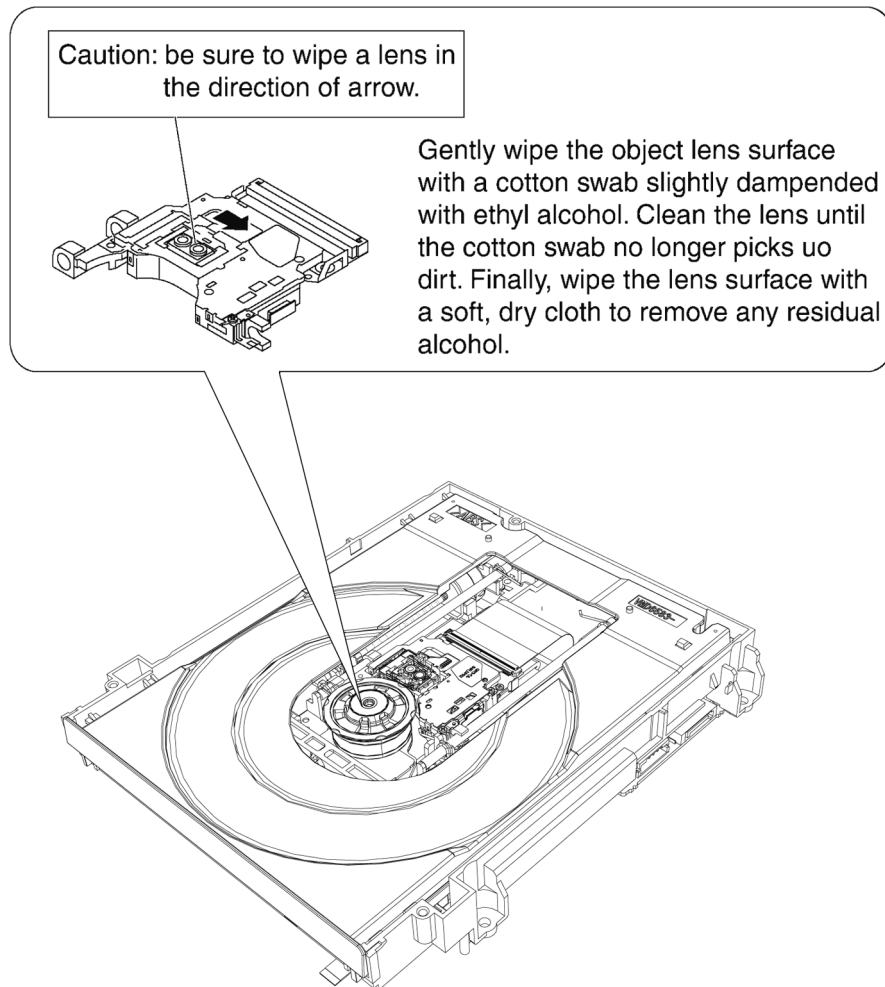

9.3.8. Service hint

If a defective phenomenon is "NO READ", please try to clean TT (turn table) in the drive in according to the following procedure.

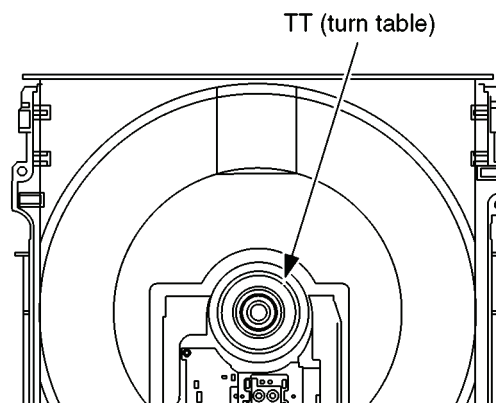

1. Blow off dust on TT by a blower. (Air must not blow to it strongly.)

Caution : Move outside to protect OPU.

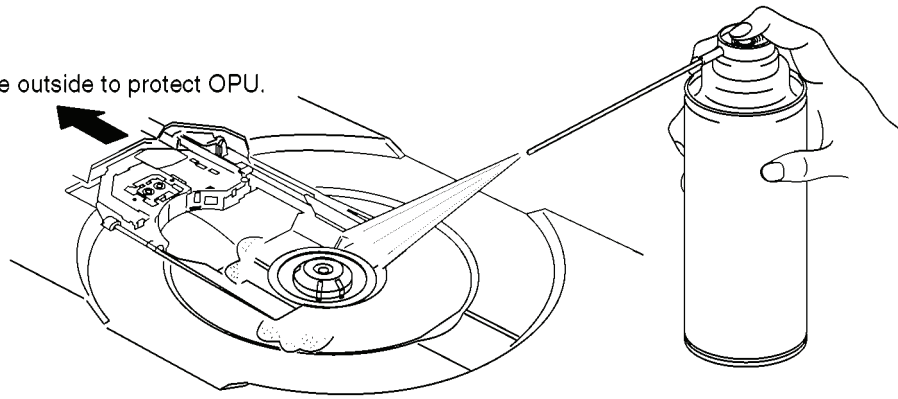

2. Apply one drop of ethyl alcohol or isopropyl alcohol on a clean cotton swab.
(Always use a fresh cotton swab free from any additive or chemical.)

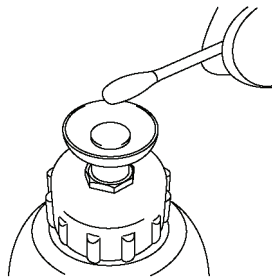

3. Lightly put the cotton swab on TT, and wipe it by turning by your finger.
(Don't touch the surface of TT when you turn it.)

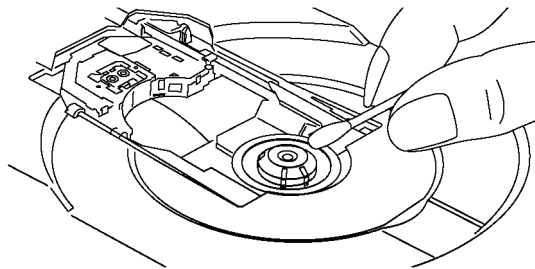

10 Measurements and Adjustments

10.1. Service Positions

NOTE:

For description of the disassembling procedure, see the section 9.

10.1.1. Checking and Repairing of Main P.C.B.

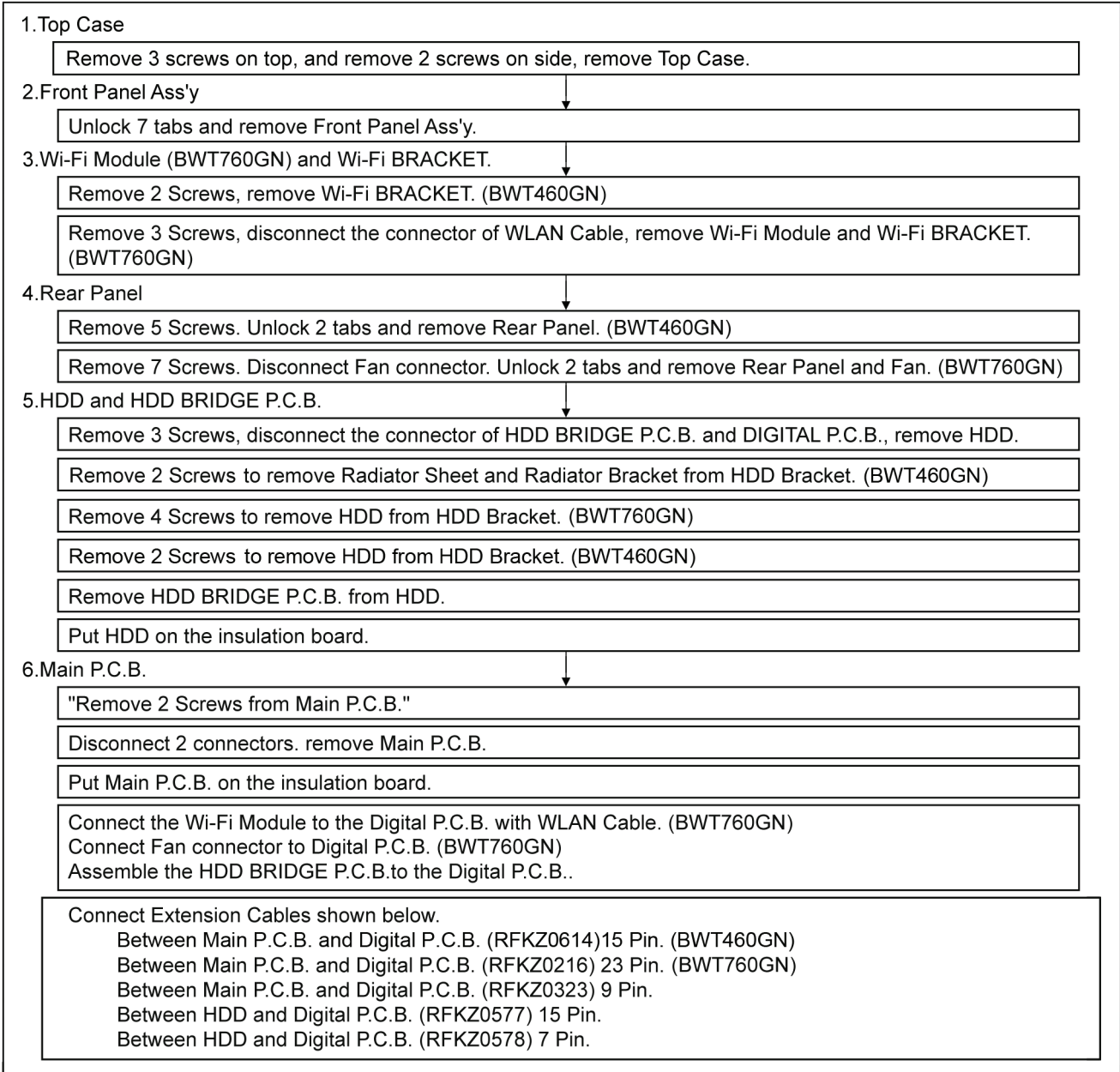

Caution :

1. Red wire should be connected to pin 1.

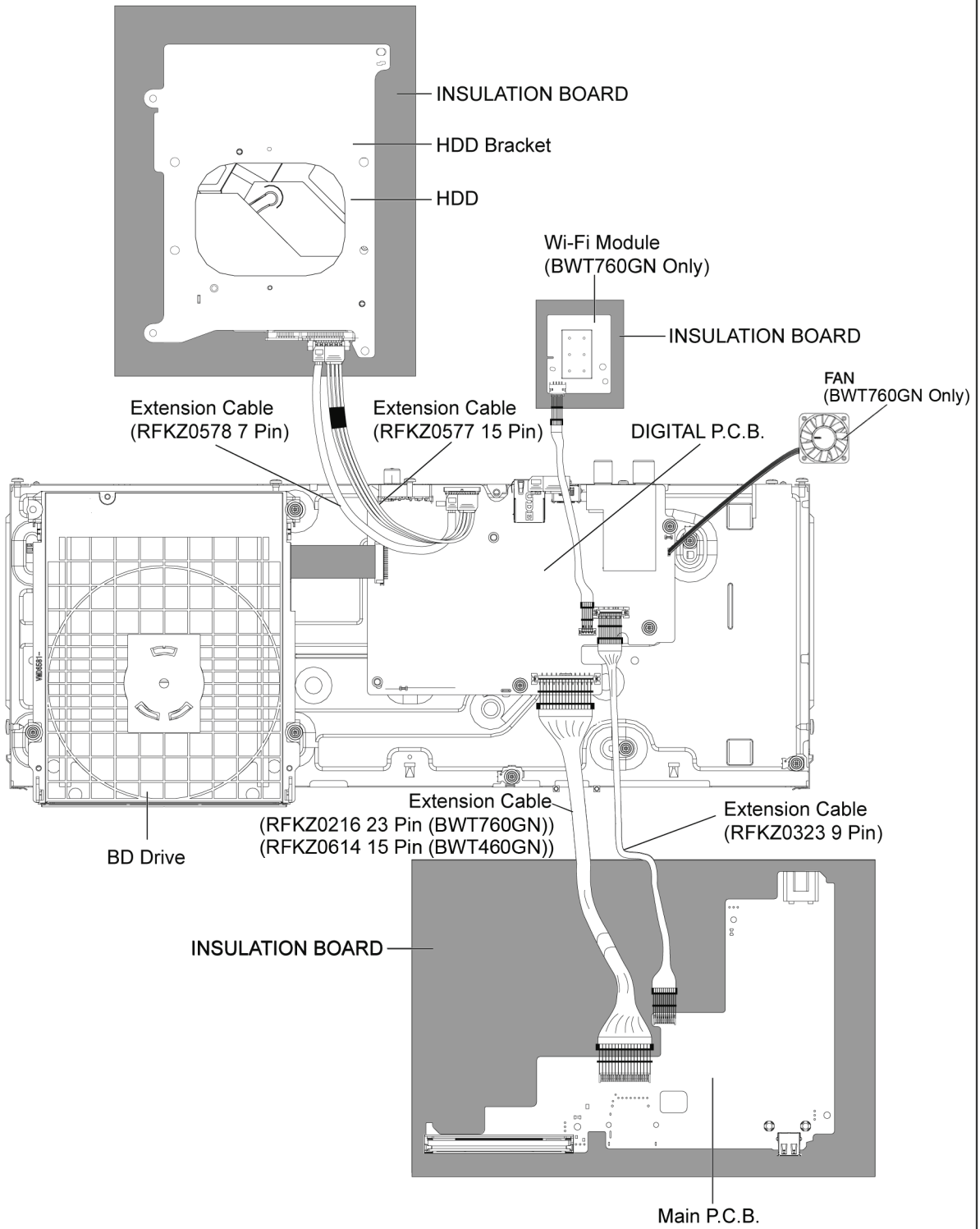

10.1.2. Checking and Repairing of Digital P.C.B.

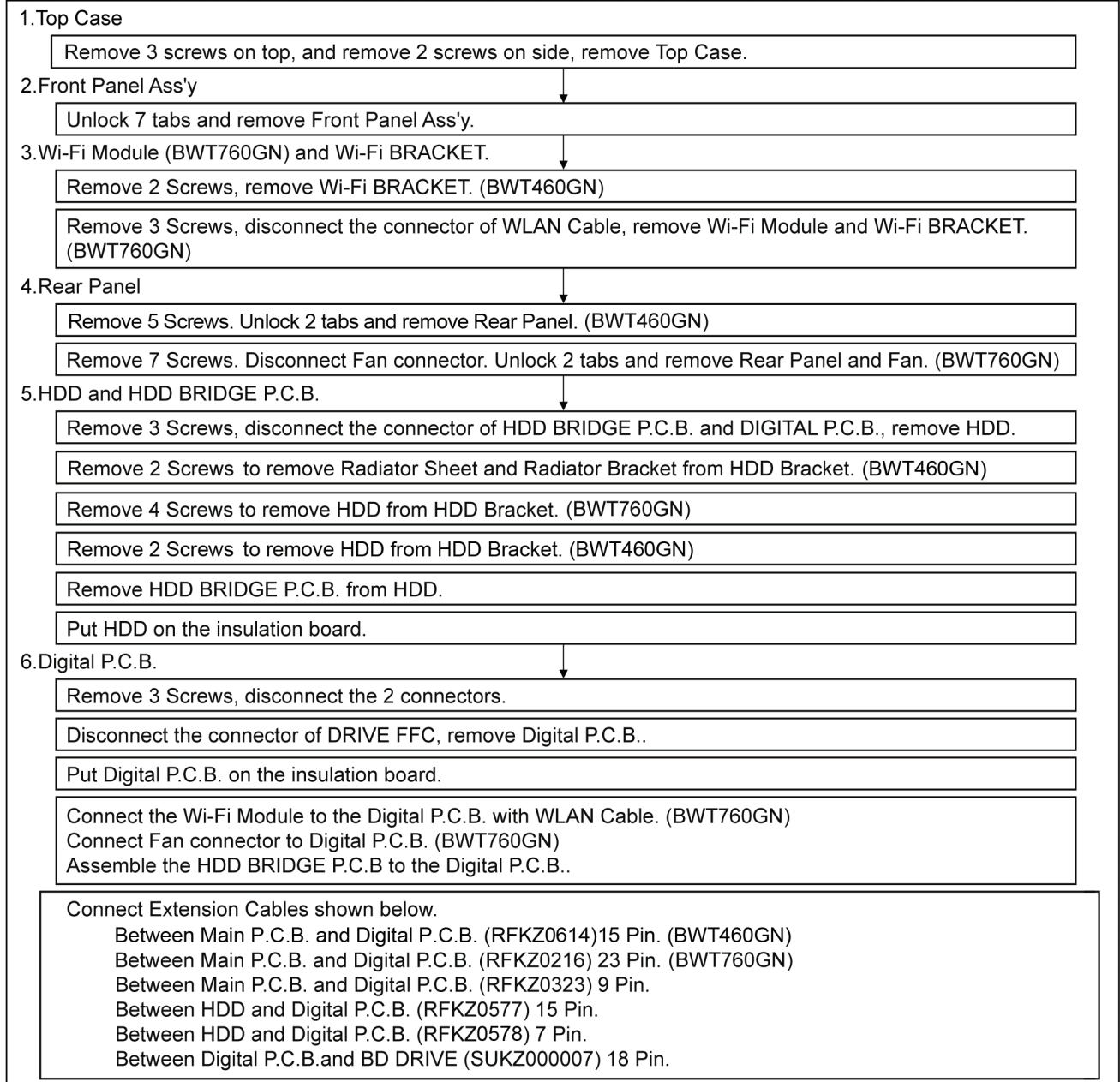

Caution :

- 1. Red wire should be connected to pin 1.

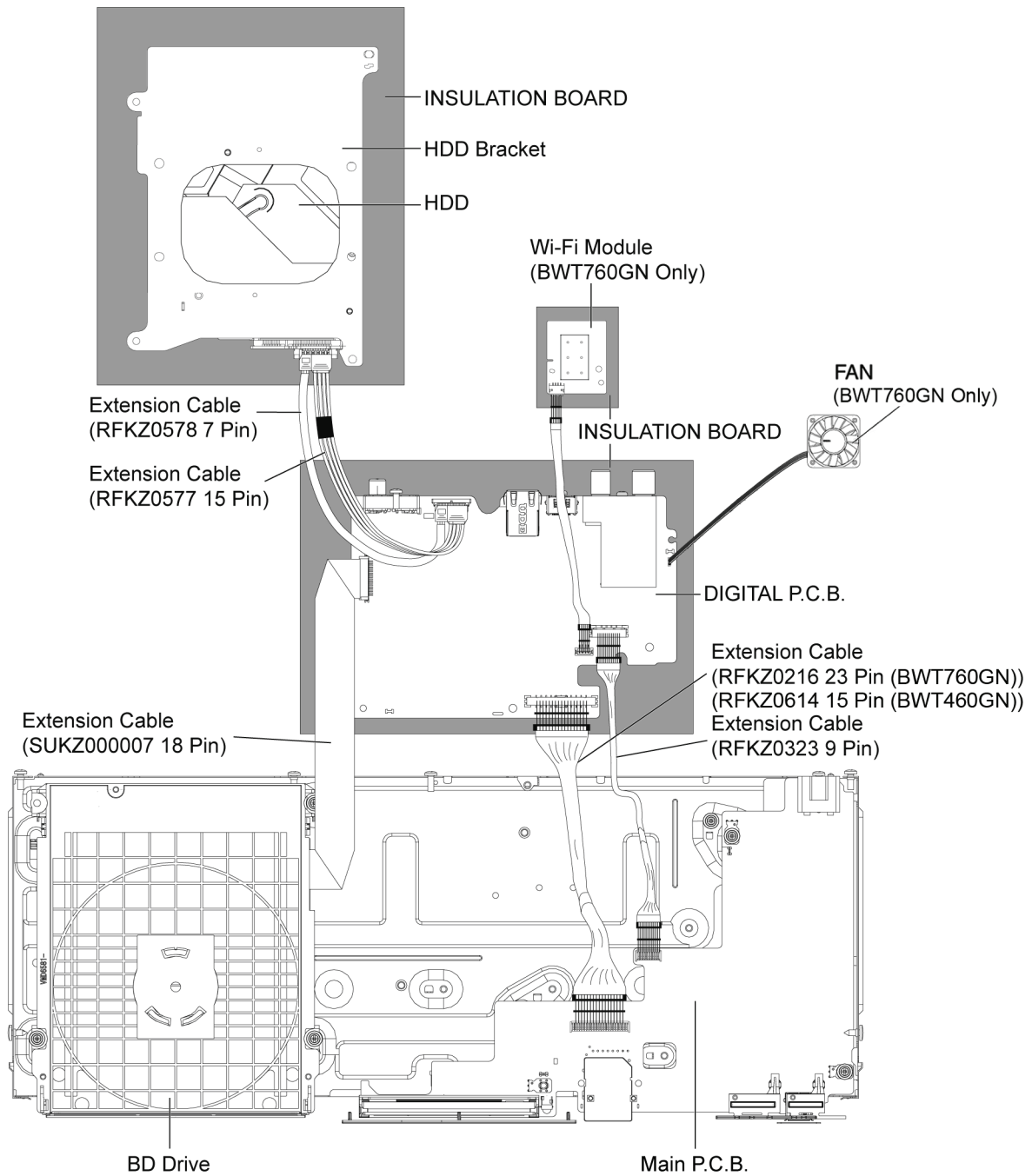

10.1.3. Checking and Repairing of HDD

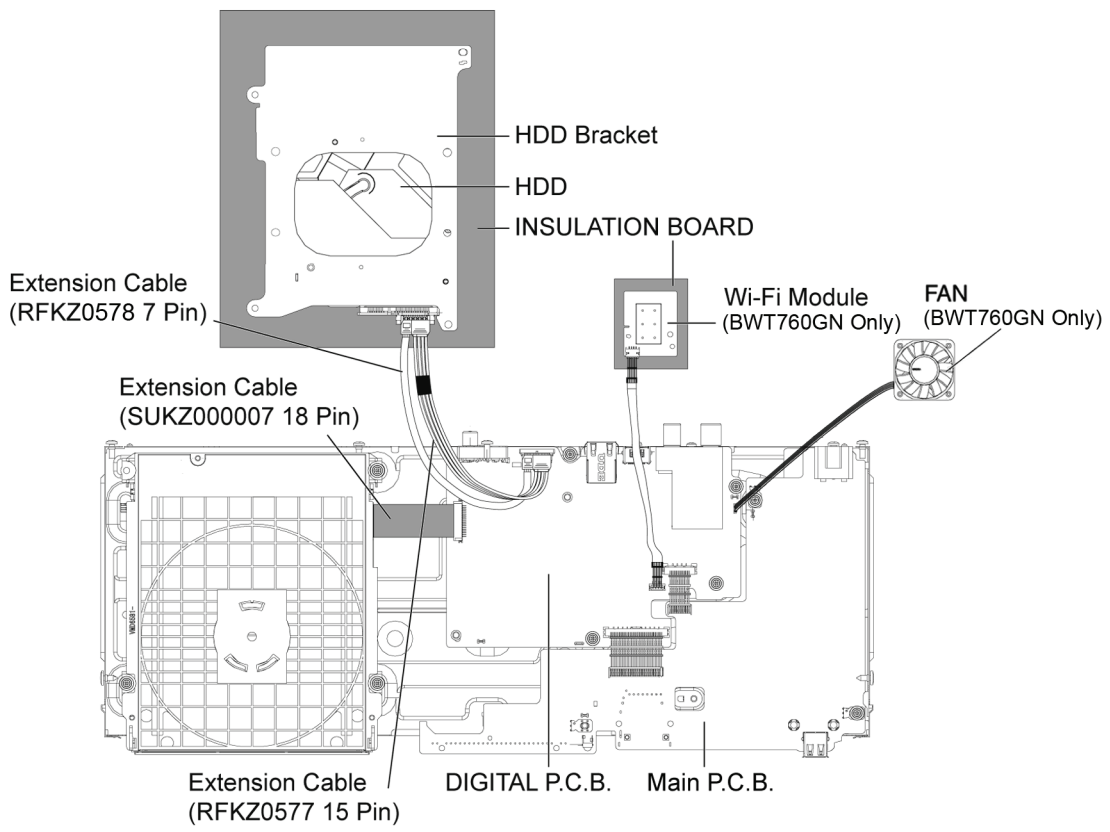
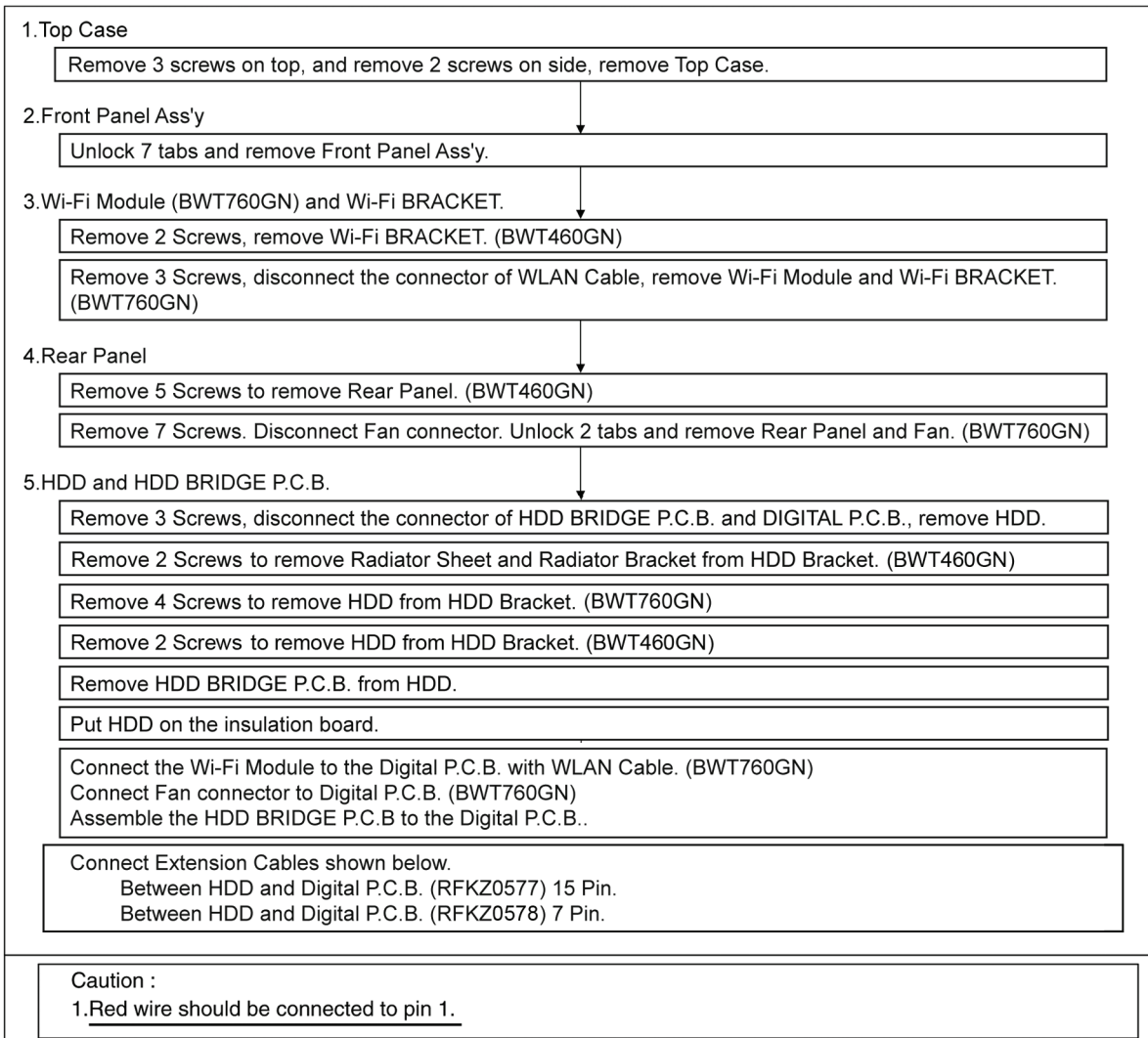

10.1.4. Checking and Repairing of BD Drive

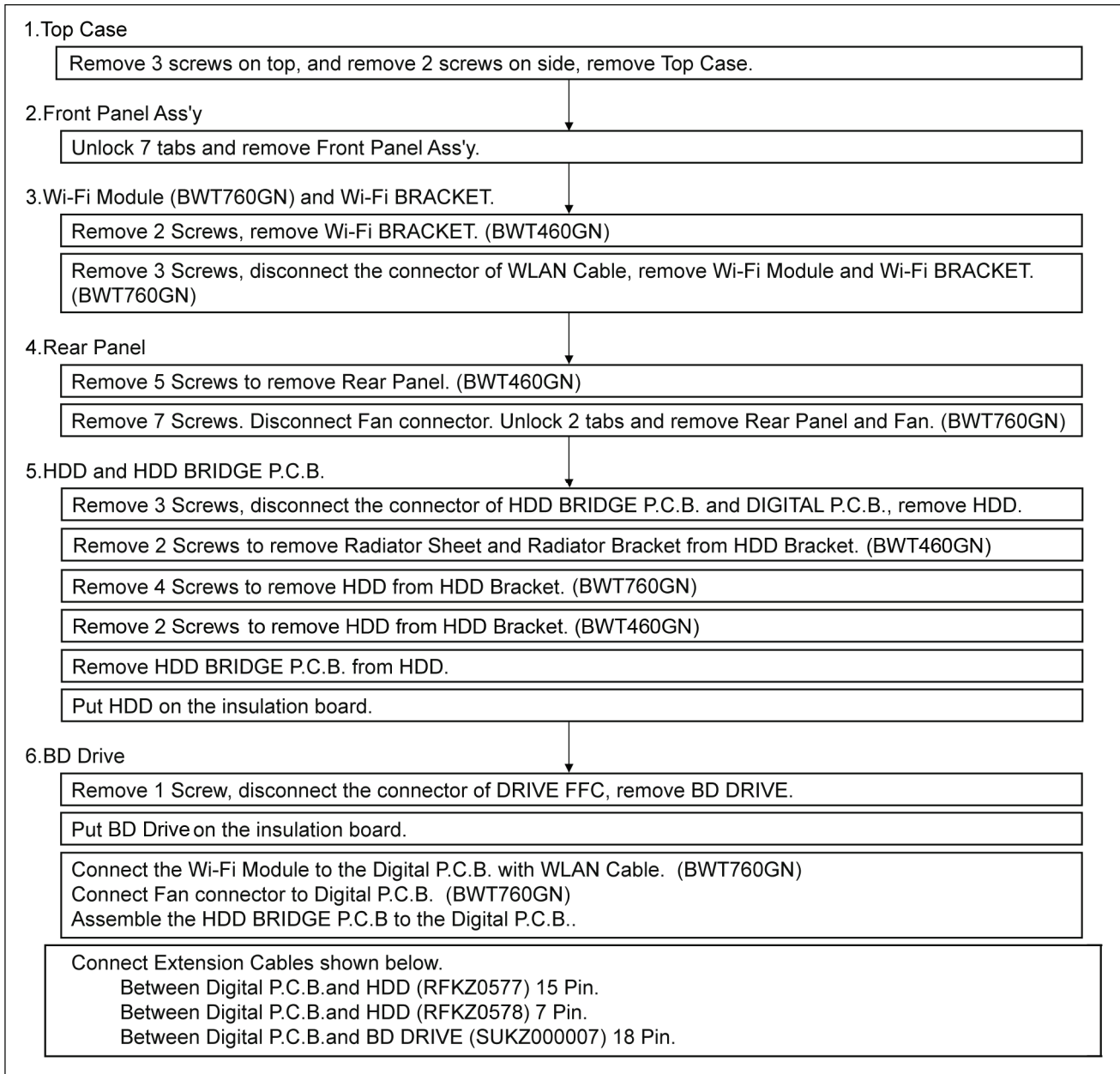

Caution :

1. Red wire should be connected to pin 1.

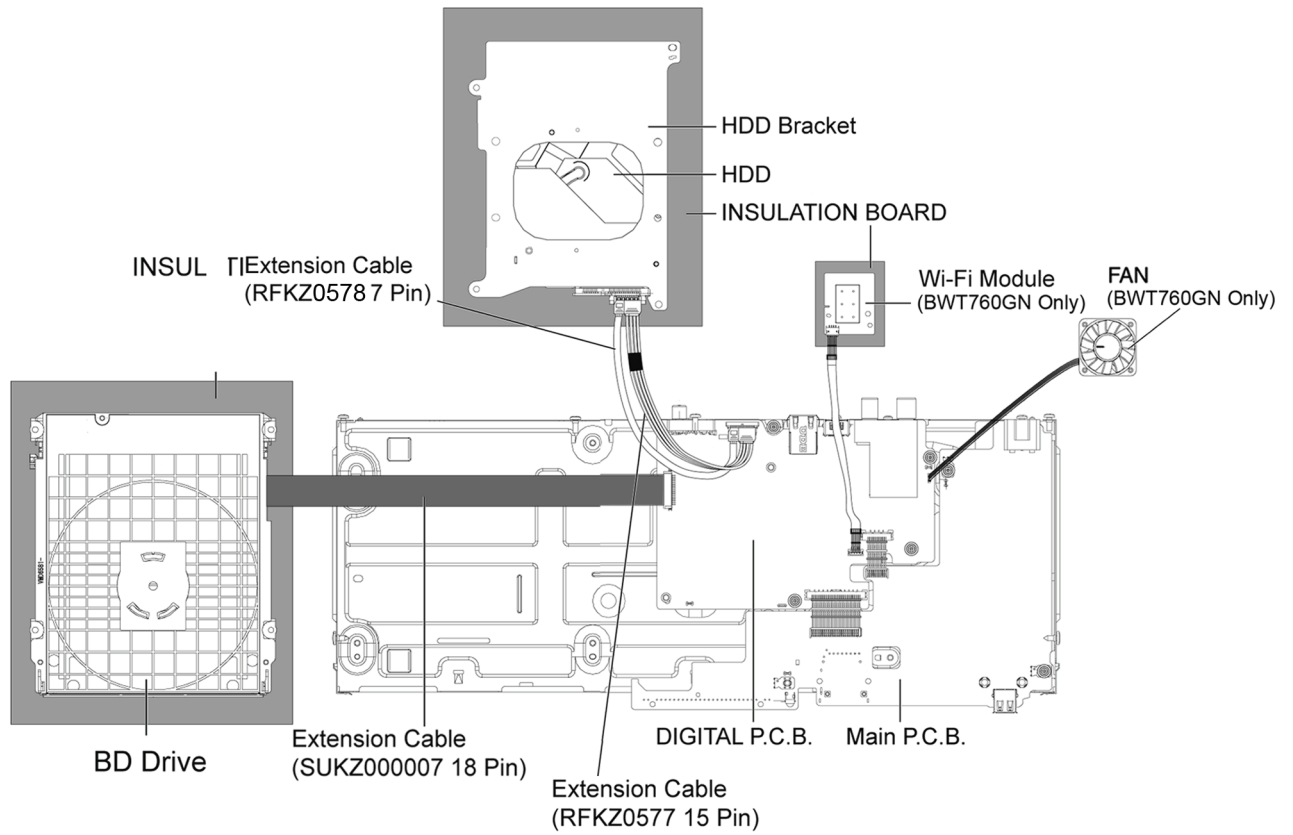

10.2. Caution for Replacing Parts

10.2.1. Items that should be done after replacing parts

✓ :Necessary — :Unnecessary

Replacing Parts \ Items that Should be done	Main Firm update	HDD Format
Digital P.C.B.	✓	—
Main P.C.B. (IC9501:EEPROM)	—	✓
BD Drive	✓	—
HDD	—	✓

10.2.2. Notice after replacing Digital P.C.B. or BD Drive

Formatting the HDD is unnecessary after replacing Digital P.C.B. or BD Drive.

[TM AV1] is displayed, once power OFF, and power ON again.

10.3. Standard Inspection Specifications after Making Repairs

After making repairs, we recommend performing the following inspection, to check normal operation.

No.	Procedure	Item to Check
1	Turn on the power, and confirm items pointed out.	Items pointed out should reappear.
2	Insert RAM disc.	The Panasonic RAM disc should be recognized.
3	Enter the EE (TU IN / AV IN - AV OUT) mode.	No abnormality should be seen in the picture, sound or operation.
4	Model with the HDD: Perform self-recording and playback for one minute using the HDD.	No abnormality should be seen in the picture, sound or operation.
5	Perform copy a program to disc and playback for one minute using the BD-RE (V2.0) and RAM discs.	No abnormality should be seen in the picture, sound or operation. *Panasonic BD-RE (V2.0) and DVD-RAM discs should be used when copying and playback.
6	If a problem is caused by a VCD, DVD-R, DVD-Video, Audio-CD, or MP3, playback the test disc.	No abnormality should be seen in the picture, sound or operation.
7	Models with SD Card Slot or DV Input Jack or USB Input Jack: In case of that the trouble is caused by SD card and/or DV terminal and / or USB terminal.	Models with SD Card or DV Input Jack; 1) SD Card: Check to be able to display and copy the picture. 2) DV terminal: Check to be able to record from DVC. 3) USB terminal: Check to be able to display and copy the picture.
8	After checking and making repairs, upgrade the firmware to the latest version.	Do not turn the power off until writing is complete (The tray automatically opens when writing is complete.). "NoUPDATE" message indicates that updating the version is not necessary since the version is the latest or the same one.
9	Transfer [9][9] in the service mode setting, and initialize the service settings (return various settings and error information to their default values. The laser time is not included in this initialization).	Make sure that [CLR] appears in the LCD display. After checking it, turn the power off.

Use the following checklist to establish the judgement criteria for the picture and sound.

Item	Contents	Check	Item	Contents	Check
Picture	Block noise		Sound	Distorted sound	
	Crosscut noise			Noise (static, background noise, etc.)	
	Dot noise			The sound level is too low.	
	Picture disruption			The sound level is too high.	
	Not bright enough			The sound level changes.	
	Too bright				
	Flickering color				
Color fading					

11 Block Diagram

11.1. Overall Block Diagram

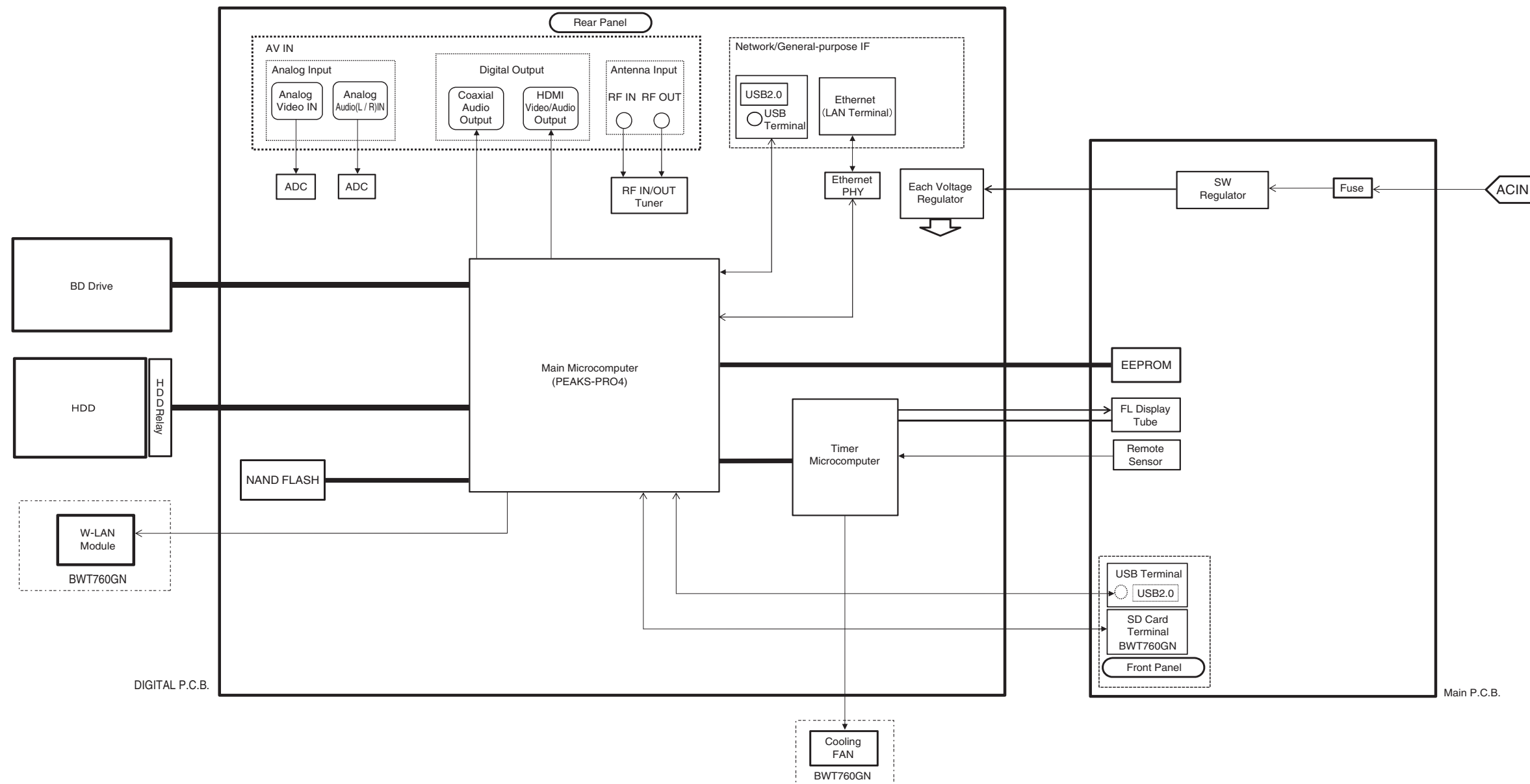

DMR-BWT460GN
DMR-BWT760GN
Overall Block Diagram

11.2. Power Supply Block Diagram

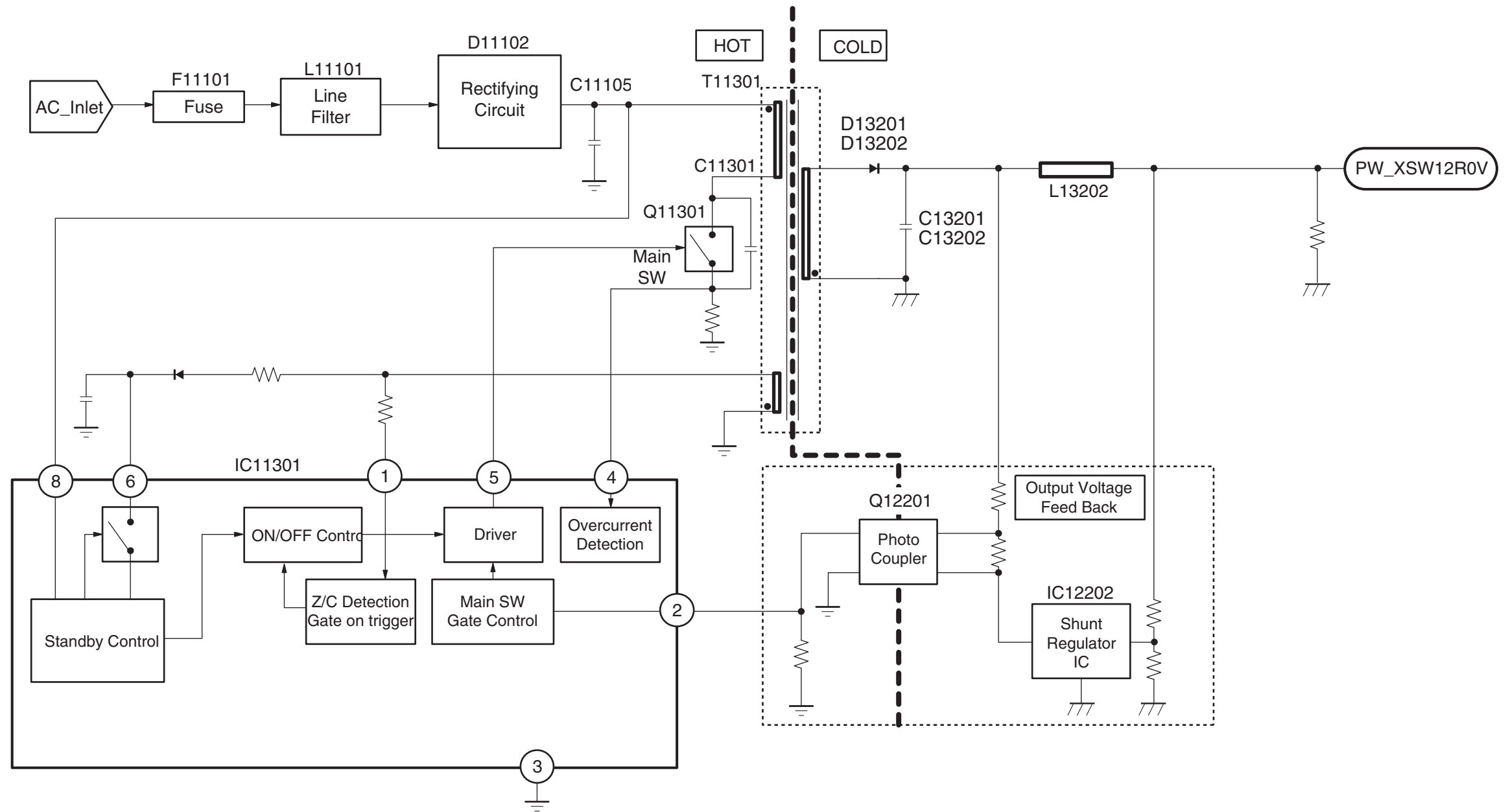

DMR-BWT460GN
DMR-BWT760GN
Power Supply Block Diagram

12 Wiring Connection Diagram

12.1. Interconnection Schematic Diagram

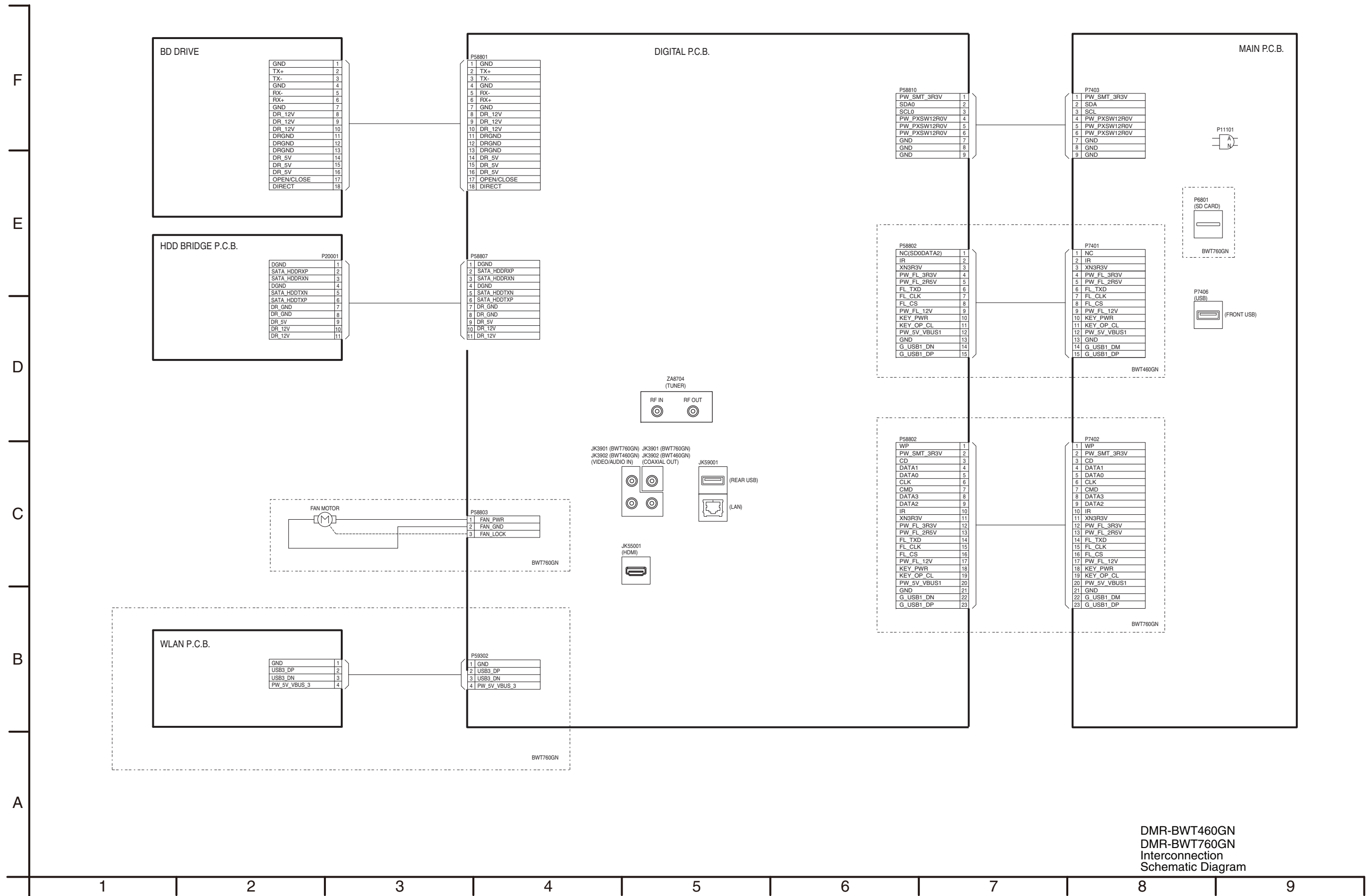

DMR-BWT460GN
DMR-BWT760GN
Interconnection
Schematic Diagram

13 Schematic Diagram

Please click the radio button for "Diagrams II / Parts List " on the menu bar in XML Service Manual.
If you want to print, please click the icon button for "Print" on the icon bar and select the item.

14 Printed Circuit Board

Please click the radio button for "Diagrams II / Parts List " on the menu bar in XML Service Manual.
If you want to print, please click the icon button for "Print" on the icon bar and select the item.

15 Exploded View and Replacement Parts List

Please click the radio button for "Diagrams II / Parts List " on the menu bar in XML Service Manual.
If you want to print, please click the icon button for "Print" on the icon bar and select the item.